

DOOR ELEVATIONS

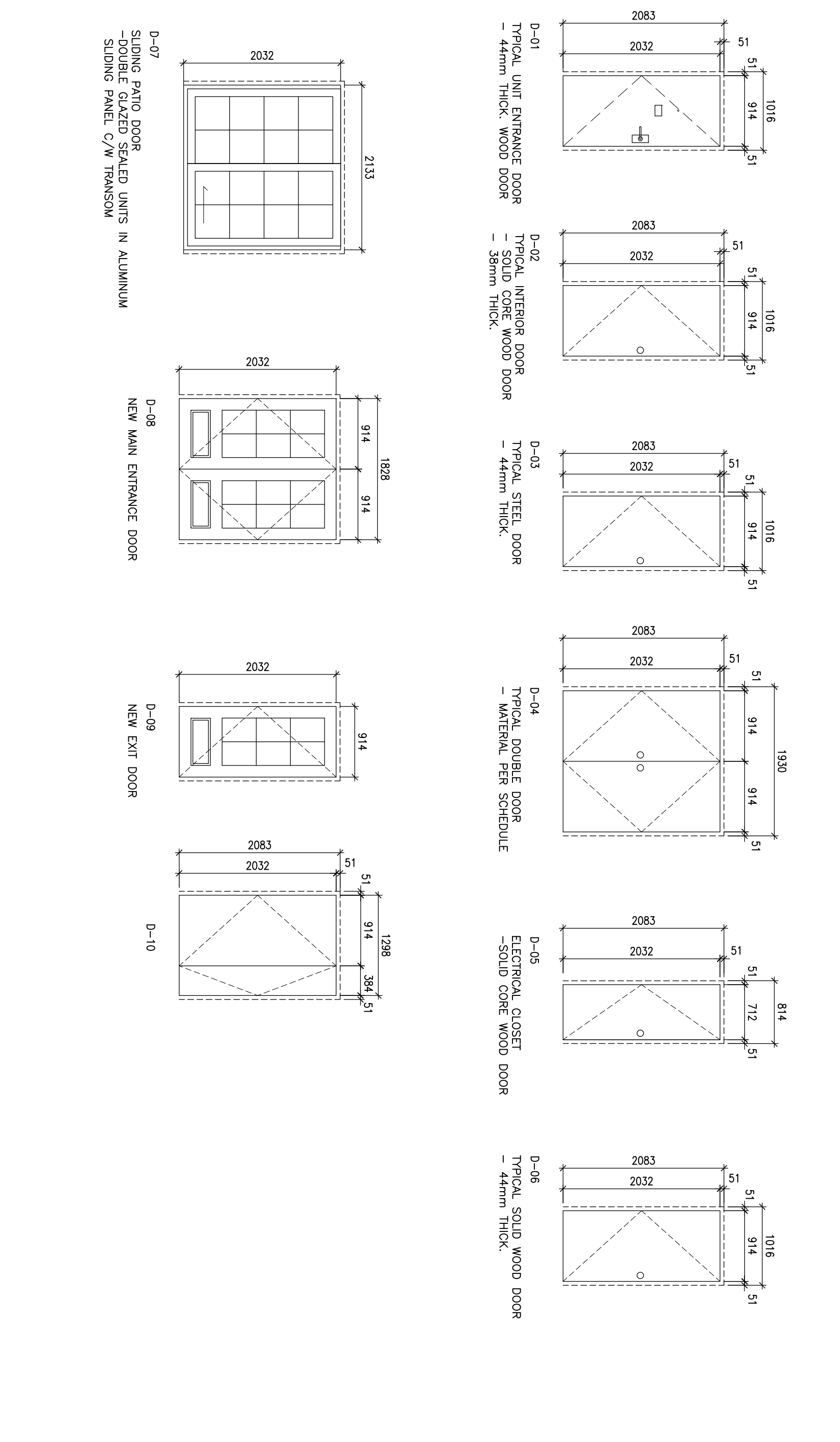

NOTE: RESUME ALL FINISHES AND COLORS PER ARCHITECT'S INTERIOR DESIGN PACKAGE.
NOTE: REFER TO PLANS FOR DOOR SIZES AND SWING DIRECTIONS.

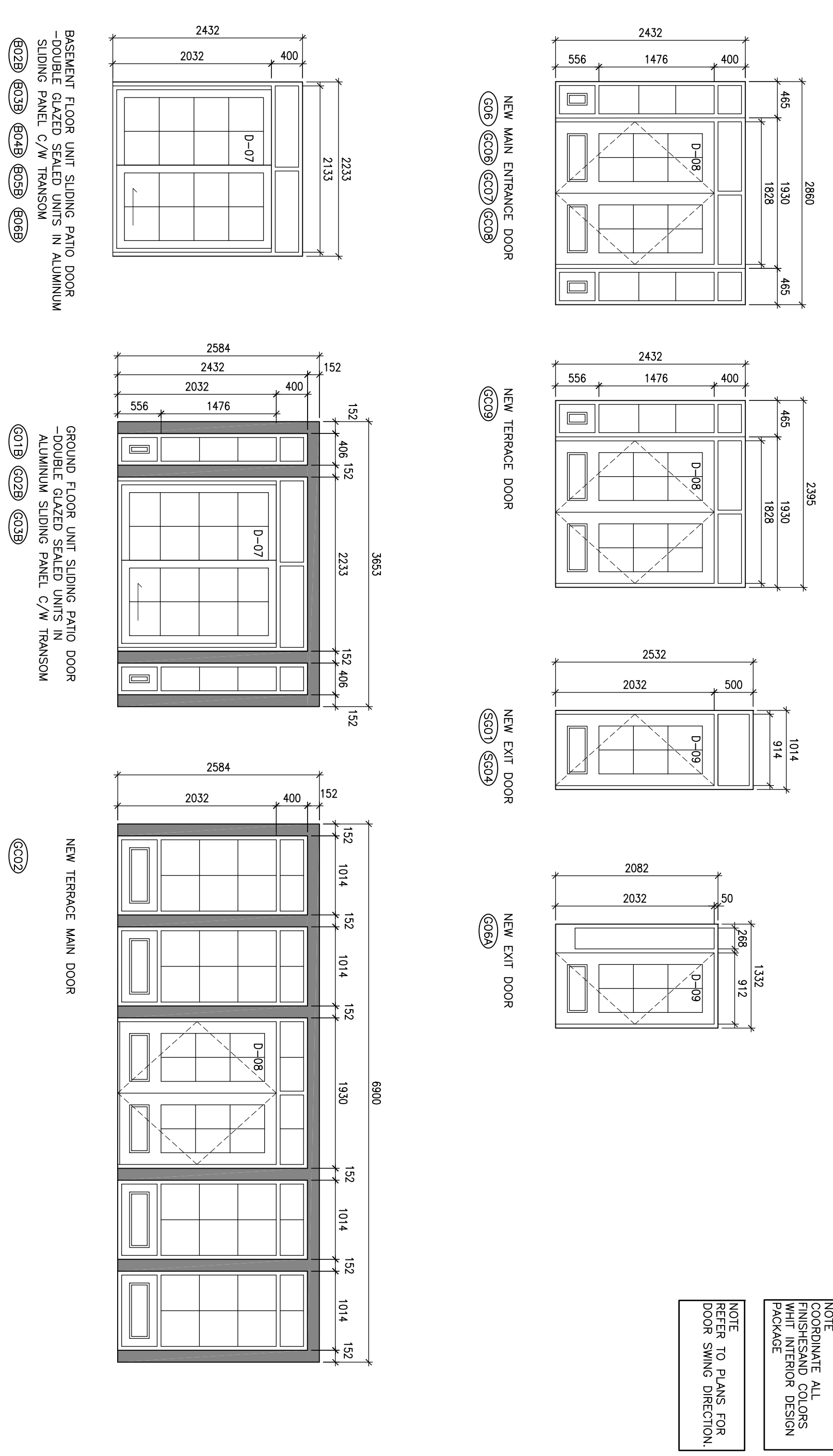

NOTE: RESUME ALL FINISHES AND COLORS PER ARCHITECT'S INTERIOR DESIGN PACKAGE.
NOTE: REFER TO PLANS FOR DOOR SIZES AND SWING DIRECTIONS.

FRAME ELEVATIONS

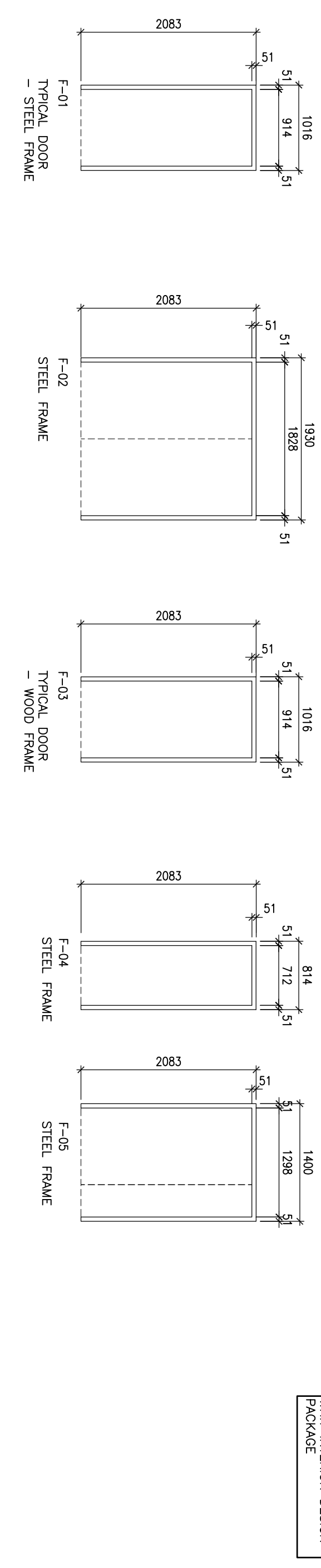

1 DOOR AND FRAME ELEVATIONS AND HARDWARE NOTES

WINDOW ELEVATIONS

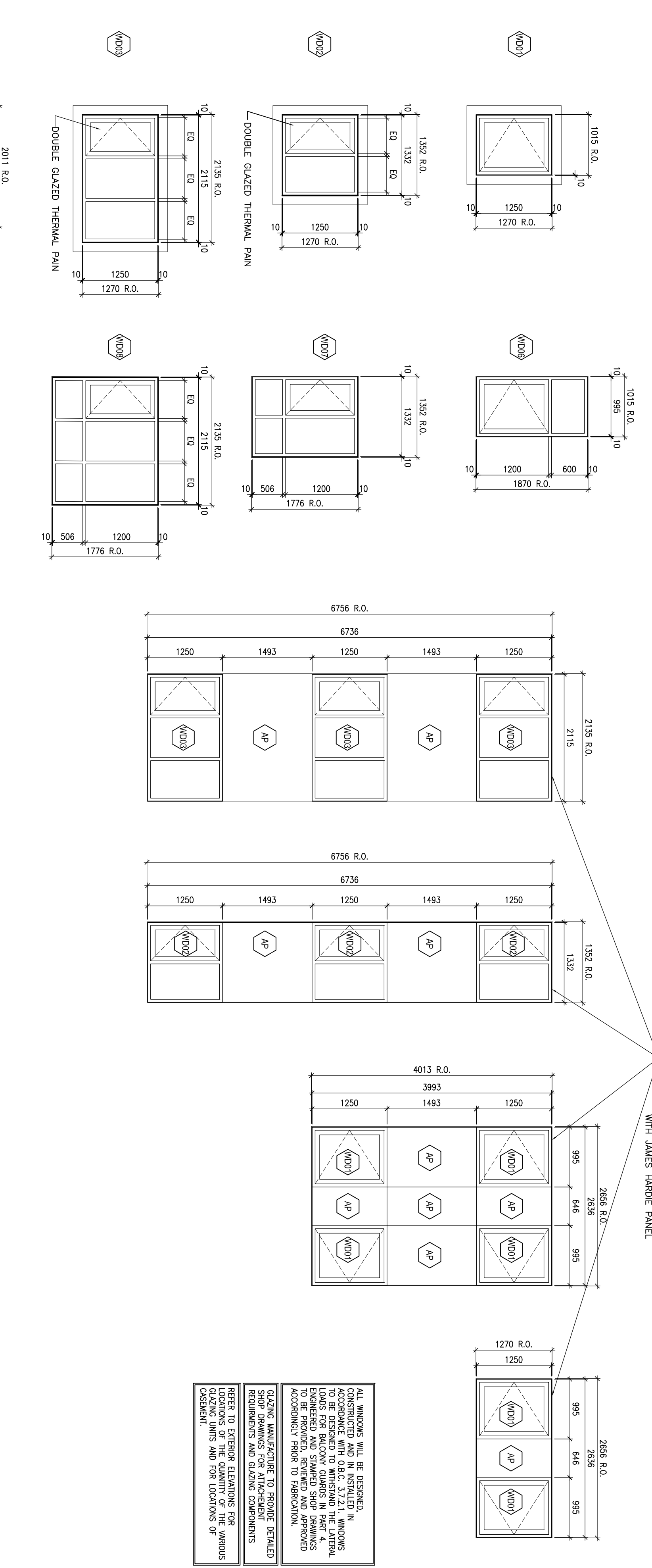

NOTE: RESUME ALL FINISHES AND COLORS PER ARCHITECT'S INTERIOR DESIGN PACKAGE.
NOTE: REFER TO PLANS FOR WINDOW SIZES AND SWING DIRECTIONS.



NOTE: RESUME ALL FINISHES AND COLORS PER ARCHITECT'S INTERIOR DESIGN PACKAGE.
NOTE: REFER TO PLANS FOR WINDOW SIZES AND SWING DIRECTIONS.

2 WINDOW ELEVATIONS

LAYOUT OF WINDOWS SHOWN WITH JAMES HUBLE PANEL.

ALL DIMENSIONS SHALL BE EXACTLY AS SHOWN ON THIS DRAWING. CONTRACTOR SHALL VERIFY ALL DIMENSIONS ON SITE AND TO REPORT ALL ERRORS AND/OR OMISSIONS TO THE ARCHITECT. ALL CONTRACTORS MUST COMPLY WITH ALL CODES AND REGULATIONS AND OTHER AUTHORITIES HAVING JURISDICTION OVER THE WORK. DO NOT SCALE DRAWINGS. THIS DRAWING MAY NOT BE USED FOR CONSTRUCTION UNLESS SIGNED BY THE ARCHITECT. COPYRIGHT RESERVED.

<p>WOODMAN ARCHITECT ASSOCIATES LTD.</p> <p>4 BEECHWOOD, SUITE 201, OTTAWA, ONTARIO, CANADA K1L 8L9 TEL: 613 228 8850 FAX: 613 228 8848 MAIL: info@woodmanarchitect.com</p>		<p>PROJECT: LONG SAULT VILLA PROPOSED NEW LINKED BUILDING</p>	
<p>CONSULTANTS: STRUCTURAL - WSP MECHANICAL - BGA ELECTRICAL - BGA</p>		<p>DATE: DECEMBER 23 2014 JOB NO.: 1242</p> <p>SCALE: N=1/32 DRAWING NO.: SC02</p> <p>DRAWN BY: S.S. CHECKED BY: R.L.M.</p>	
<p>NO. REVISION</p>		<p>NO. REVISION</p>	
01	ISSUED FOR BUILDING PERMIT	12/23/14	MADDOXY DAVIS
02	ISSUED FOR COORDINATION	11/02/15	
03	ISSUED FOR COORDINATION	04/06/15	
04	ISSUED FOR TENDER	05/08/15	
05	ISSUED FOR COST CONSULTANT REVIEW	14/09/15	
06	ISSUED FOR FINAL COORDINATION	13/11/15	
07	ISSUED FOR CONSTRUCTION	19/11/15	
08	RESUBMITTED FOR CONSTRUCTION	08/12/15	
09			
10			
11			
12			
13			
14			
15			
16			
17			
18			
19			

