

THESE DRAWINGS ARE THE PROPERTY OF RONNEY ENGINEERING LIMITED. NO PART OF THESE DRAWINGS IS TO BE REPRODUCED OR TRANSMITTED IN ANY FORM OR BY ANY MEANS, ELECTRONIC OR MECHANICAL, INCLUDING PHOTOCOPYING, RECORDING, OR BY ANY INFORMATION STORAGE AND RETRIEVAL SYSTEM, WITHOUT THE WRITTEN PERMISSION OF RONNEY ENGINEERING LIMITED.

SECTION 1
 5/8" x 11/8"

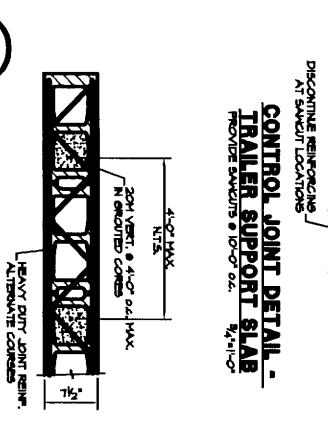

NO.	REV.	DATE	DESCRIPTION
1	1/2/04		ISSUED FOR PERMIT
2			
3			

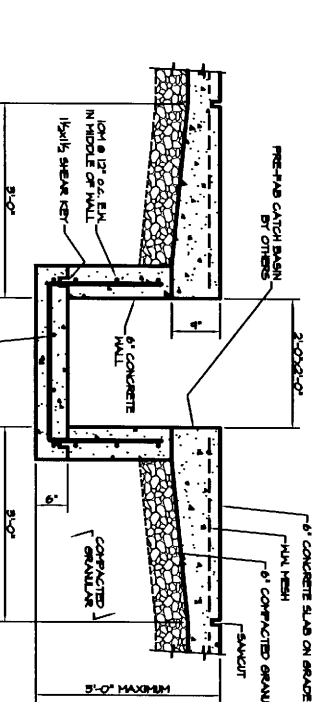
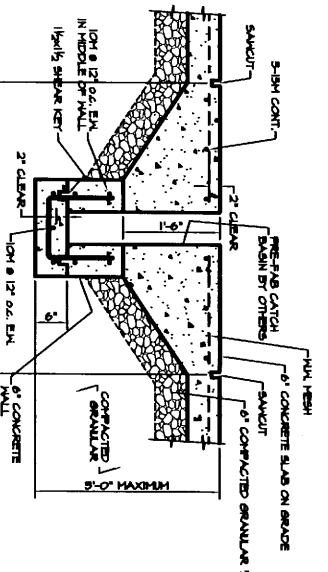
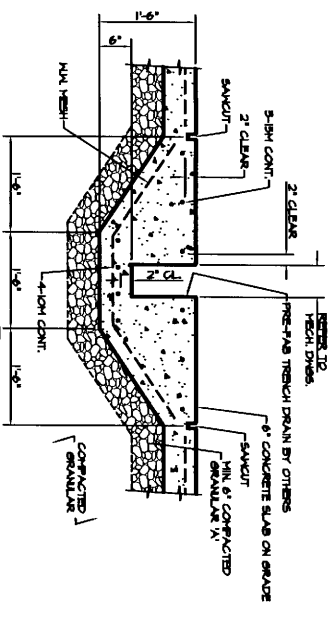
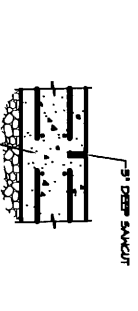
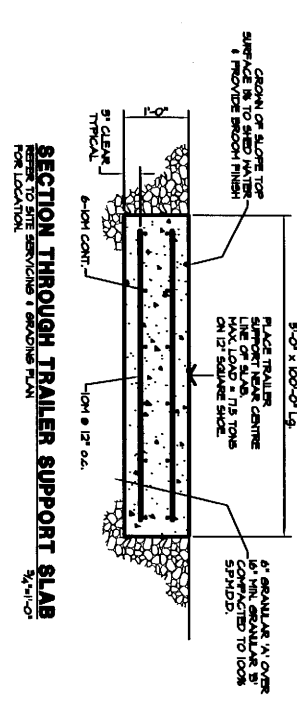
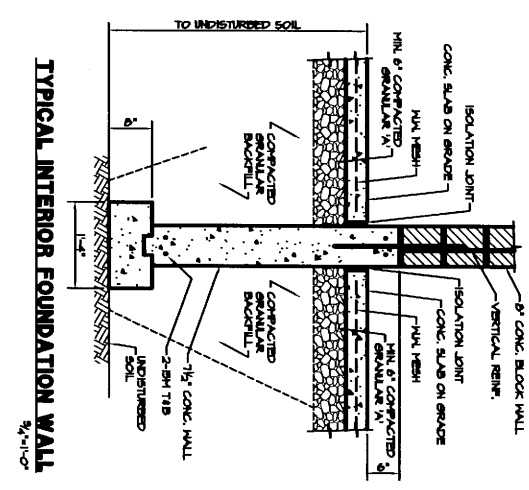
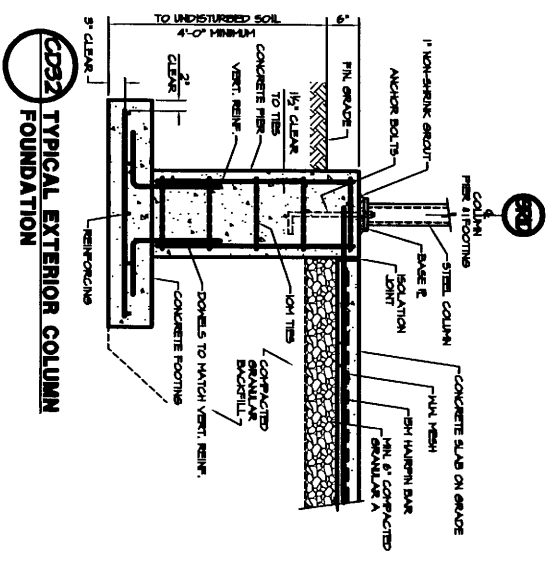
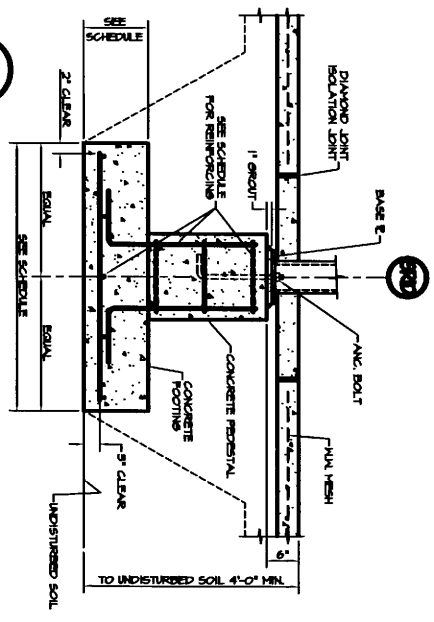
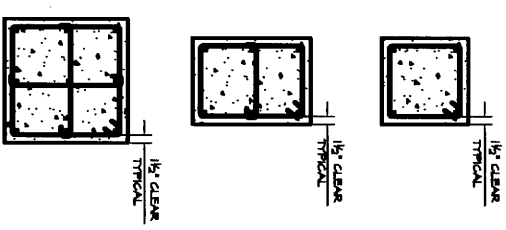
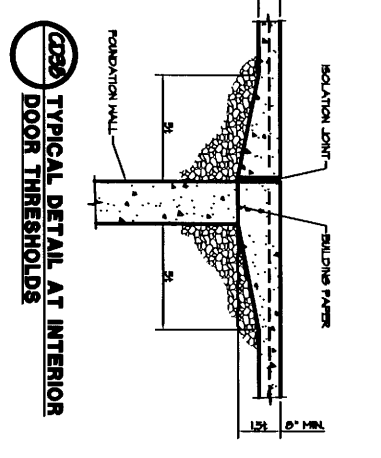
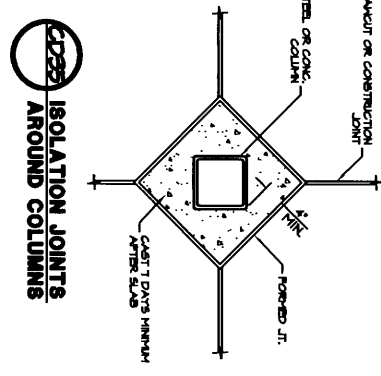
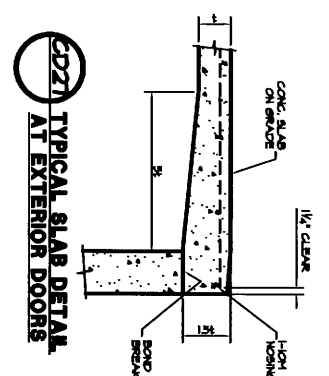
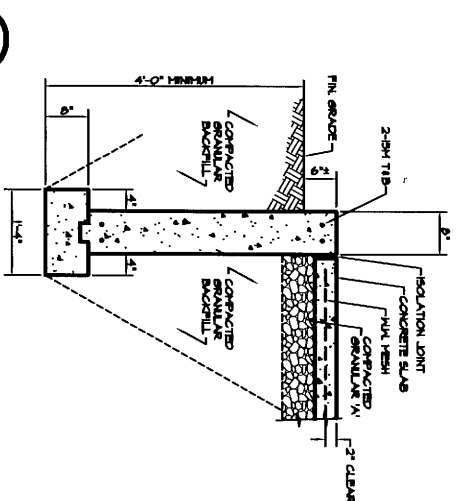
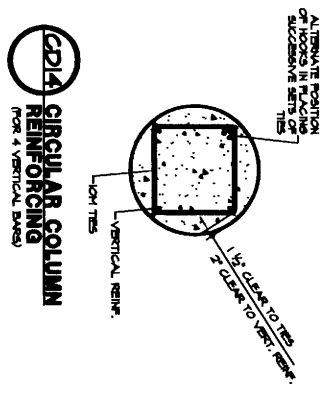
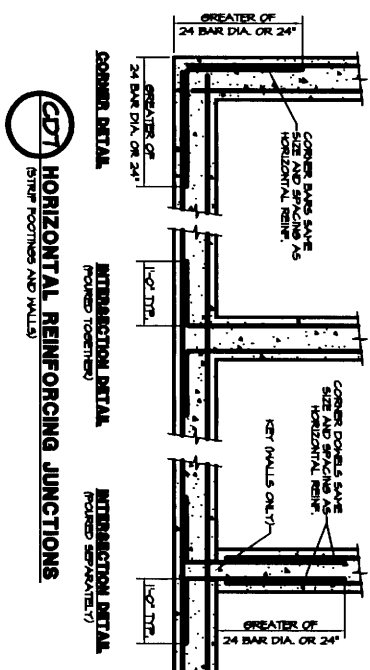
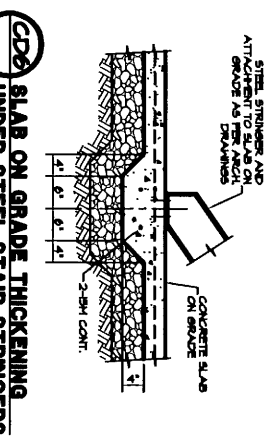
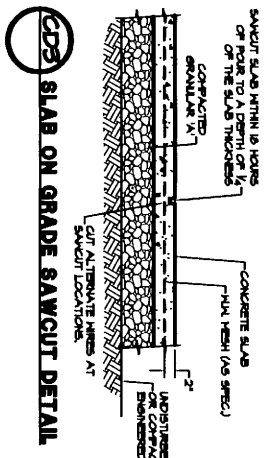
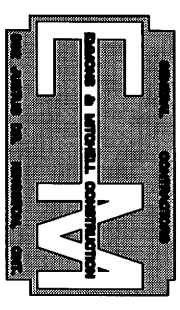

NEW STRUCTURE FOR INTERNATIONAL TRUCKS DALTON, AVE. KINGSTON, ONTARIO
FOUNDATION SECTIONS AND DETAILS

NOTES:
 1. ALL DIMENSIONS UNLESS OTHERWISE SPECIFIED ARE IN METERS.
 2. ALL DIMENSIONS UNLESS OTHERWISE SPECIFIED ARE IN METERS.
 3. ALL DIMENSIONS UNLESS OTHERWISE SPECIFIED ARE IN METERS.
 4. ALL DIMENSIONS UNLESS OTHERWISE SPECIFIED ARE IN METERS.
 5. ALL DIMENSIONS UNLESS OTHERWISE SPECIFIED ARE IN METERS.

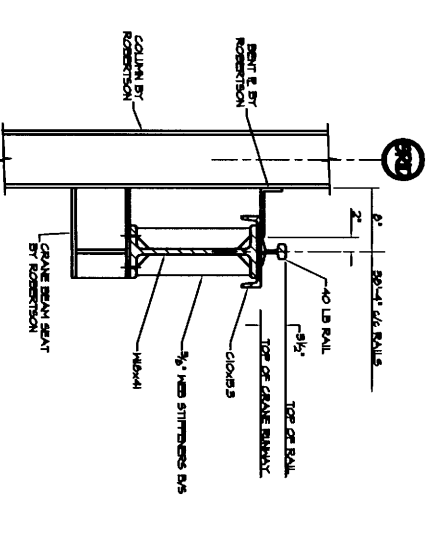

SECTION THROUGH CRANE GIRDER (1)
 1/4"=1'-0"

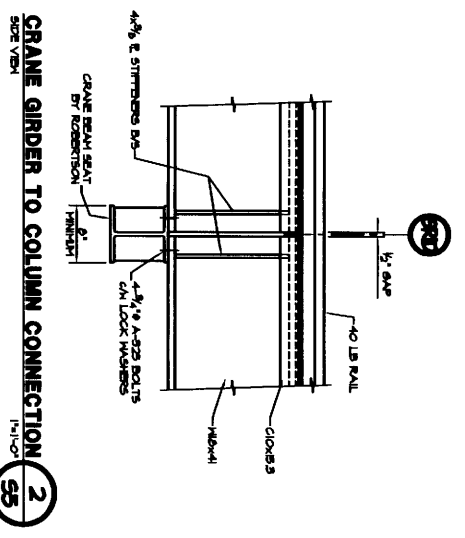

CRANE GIRDER TO COLUMN CONNECTION (2)
 1/4"=1'-0"

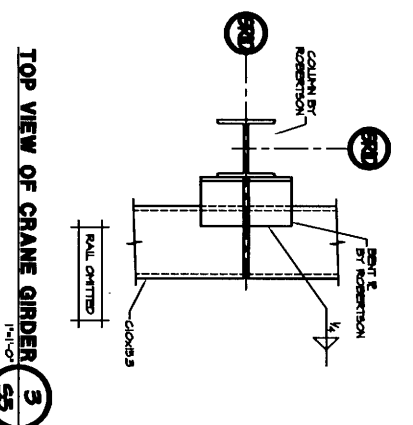

TOP VIEW OF CRANE GIRDER (3)
 1/4"=1'-0"

CRANE GIRDER TO COLUMN CONNECTION (4)
 1/4"=1'-0"

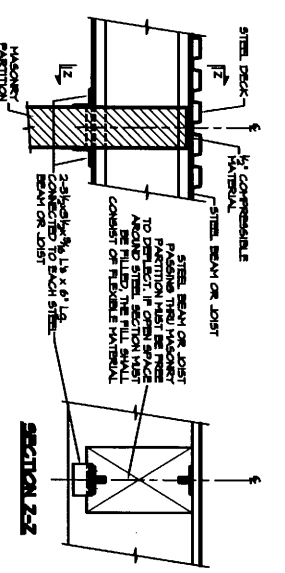

DETAIL OF LATERAL SUPPORT FOR MASONRY PARTITIONS (5)

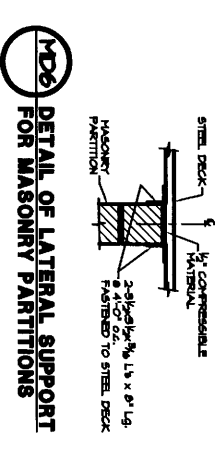

DETAIL OF LATERAL SUPPORT FOR MASONRY PARTITIONS (5)

BEARING PLATES

- M1, 7/8" x 8" x 1/2" Lg.
- M2, 1 1/2" x 6" x 1/2" Lg.
- M3, 1 1/2" x 6" x 1/2" Lg.
- M4, 1 1/2" x 6" x 1/2" Lg.
- M5, 2 3/4" x 6" x 1/2" Lg.

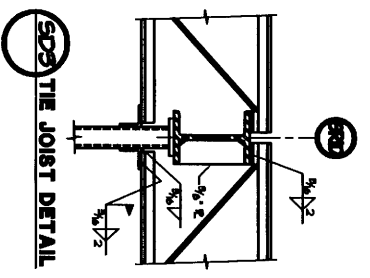

5C1 TIE JOIST DETAIL

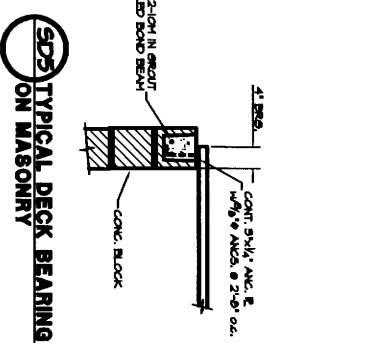

5C2 TYPICAL DECK BEARING ON MASONRY

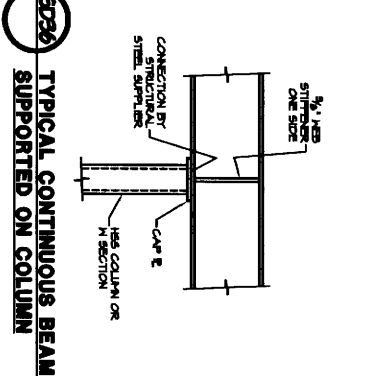

5C3 TYPICAL CONTINUOUS BEAM SUPPORTED ON COLUMN

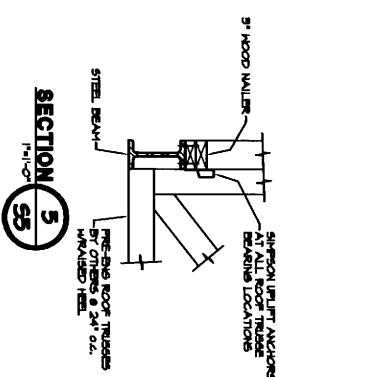

SECTION (5)
 1/4"=1'-0"

LINTEL SCHEDULE			
MARK	SIZE	BEARING LENGTH	REMARKS
L1	3-1/2" x 1/2" x 1/4" LVL	6"	
L2	3-1/2" x 1/2" x 1/4" LVL	6"	

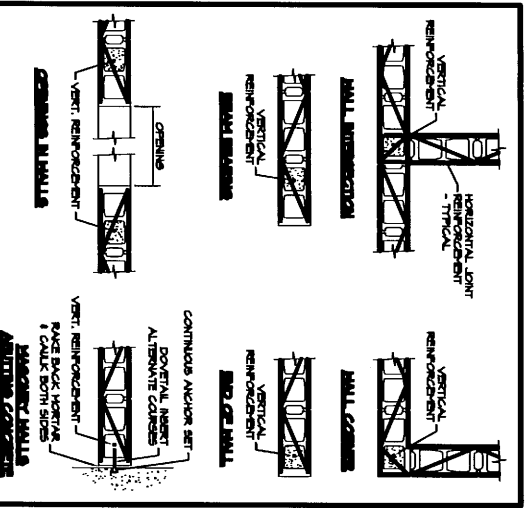

1. PROVIDE REINFORCED CORNER & THE SECTIONS FOR JOINT REINFORCEMENT.
2. LAP USE USE FOR VERTICAL REINFORCEMENT AS PER DIVISIONS UNLESS OTHERWISE SPECIFIED IN THIS SECTION.
3. PROVIDE DOOR/LINE INTO FOUNDATION WALL FOR ALL VERTICAL BARS.
4. BARS SHOWN ARE TO BE PLACED IN ADDITION TO REINFORCEMENT SPECIFIED ELSEWHERE.
5. VERTICAL REINFORCEMENT SHOWN SHALL BE AS FOLLOWS:

WALL THICKNESS	VERTICAL REINFORCING
140 (47)	2M
160 (52)	2M
240 (79)	3-2M
280 (93)	3-2M

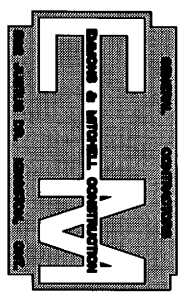

NEW STRUCTURE FOR INTERNATIONAL TRUCKS
 DALTON, AVE.
 MISSISSAUGA, ONTARIO

SECTIONS & DETAILS
 DAMON & MITCHELL
 CONSULTING ENGINEERS
 CONSTRUCTION

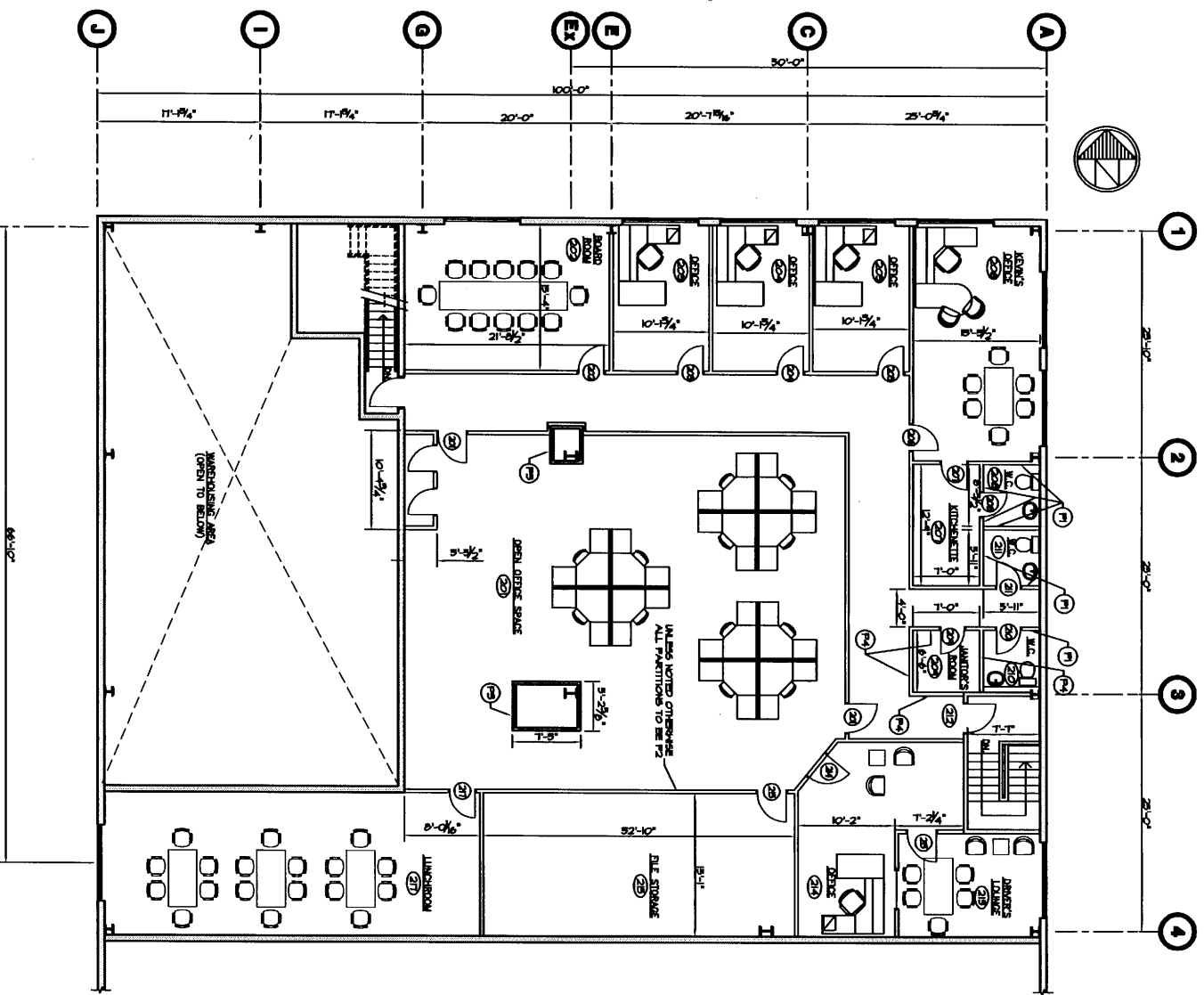

SECOND FLOOR OFFICE LAYOUT PLAN
1/8" = 1'-0"

DOOR SCHEDULE																				
DOOR NO.	SIZE	RATING	TYPE	H/HTL	FINISH	TYPE	H/HTL	FINISH	THH	GLASSING	HARDWARE			REMARKS						
										SH	HD	TRK	PNV	STP	HTL	LR	DB	PAN		
201	30x60	WA	I	HD	FT	A	HD	FT	HD	WA										
202	30x60	WA	I	HD	FT	A	HD	FT	HD	WA										
203	30x60	WA	I	HD	FT	A	HD	FT	HD	WA										
204	30x60	WA	I	HD	FT	A	HD	FT	HD	WA										
205	30x60	WA	I	HD	FT	A	HD	FT	HD	WA										
206	30x60	WA	I	HD	FT	A	HD	FT	HD	WA										
207	30x60	WA	I	HD	FT	A	HD	FT	HD	WA										
208	30x60	WA	I	HD	FT	A	HD	FT	HD	WA										
209	30x60	WA	I	HD	FT	A	HD	FT	HD	WA										
210	30x60	WA	I	HD	FT	A	HD	FT	HD	WA										
211	30x60	WA	I	HD	FT	A	HD	FT	HD	WA										
212	30x60	WA	I	HD	FT	A	HD	FT	HD	WA										
213	30x60	WA	I	HD	FT	A	HD	FT	HD	WA										
214	30x60	WA	I	HD	FT	A	HD	FT	HD	WA										
215	30x60	WA	I	HD	FT	A	HD	FT	HD	WA										
216	30x60	WA	I	HD	FT	A	HD	FT	HD	WA										
217	30x60	WA	I	HD	FT	A	HD	FT	HD	WA										

ARCHITECTURAL ABBREVIATIONS TABLE			
AT	ACROBATIC TILE	HD	HAND
CB	CONCRETE BLOCK	HD	HOLD OPEN DEVICE
CL	CLOSET	RS	ROCK SLATE
CONC	CONCRETE	LR	LOCK
CP	CABINET	LR	LAMINATE
CT	CERAMIC TILE	LIC	LATCH
DB	DIAPHRAGM WALL	HTL	HAND TRUCK
DR	DRYWOOD	HT	HAND TRUCK
FIN	FINISH	PNV	PAINT FINISH
FL	FLOOR BOARD	PLY	PLYWOOD
GL	GLASSING	PNV	PAINT FINISH
GR	GENERAL PURPOSE GLASS	FT	FLOOR FINISH
H1	HOLLOW METAL DOOR	HT	HAND TRUCK
HD	HOLLOW WOOD DOOR	RS	ROCK SLATE

ROOM FINISH SCHEDULE									
ROOM NO.	ROOM NAME	FLOOR	BASE	WALLS	CEILING	REMARKS			
201	OFFICE AREA	CT	HD	FT	FT				
202	BOARD ROOM	CT	HD	FT	FT				
203	OFFICE	CT	HD	FT	FT				
204	OFFICE	CT	HD	FT	FT				
205	OFFICE	CT	HD	FT	FT				
206	OFFICE	CT	HD	FT	FT				
207	OFFICE	CT	HD	FT	FT				
208	OFFICE	CT	HD	FT	FT				
209	OFFICE	CT	HD	FT	FT				
210	OFFICE	CT	HD	FT	FT				
211	OFFICE	CT	HD	FT	FT				
212	OFFICE	CT	HD	FT	FT				
213	OFFICE	CT	HD	FT	FT				
214	OFFICE	CT	HD	FT	FT				
215	OFFICE	CT	HD	FT	FT				
216	OFFICE	CT	HD	FT	FT				
217	OFFICE	CT	HD	FT	FT				
218	OFFICE	CT	HD	FT	FT				
219	OFFICE	CT	HD	FT	FT				
220	OFFICE	CT	HD	FT	FT				
221	OFFICE	CT	HD	FT	FT				
222	OFFICE	CT	HD	FT	FT				
223	OFFICE	CT	HD	FT	FT				
224	OFFICE	CT	HD	FT	FT				
225	OFFICE	CT	HD	FT	FT				
226	OFFICE	CT	HD	FT	FT				
227	OFFICE	CT	HD	FT	FT				
228	OFFICE	CT	HD	FT	FT				
229	OFFICE	CT	HD	FT	FT				
230	OFFICE	CT	HD	FT	FT				
231	OFFICE	CT	HD	FT	FT				
232	OFFICE	CT	HD	FT	FT				
233	OFFICE	CT	HD	FT	FT				
234	OFFICE	CT	HD	FT	FT				
235	OFFICE	CT	HD	FT	FT				
236	OFFICE	CT	HD	FT	FT				
237	OFFICE	CT	HD	FT	FT				
238	OFFICE	CT	HD	FT	FT				
239	OFFICE	CT	HD	FT	FT				
240	OFFICE	CT	HD	FT	FT				
241	OFFICE	CT	HD	FT	FT				
242	OFFICE	CT	HD	FT	FT				
243	OFFICE	CT	HD	FT	FT				
244	OFFICE	CT	HD	FT	FT				
245	OFFICE	CT	HD	FT	FT				
246	OFFICE	CT	HD	FT	FT				
247	OFFICE	CT	HD	FT	FT				
248	OFFICE	CT	HD	FT	FT				
249	OFFICE	CT	HD	FT	FT				
250	OFFICE	CT	HD	FT	FT				
251	OFFICE	CT	HD	FT	FT				
252	OFFICE	CT	HD	FT	FT				
253	OFFICE	CT	HD	FT	FT				
254	OFFICE	CT	HD	FT	FT				
255	OFFICE	CT	HD	FT	FT				
256	OFFICE	CT	HD	FT	FT				
257	OFFICE	CT	HD	FT	FT				
258	OFFICE	CT	HD	FT	FT				
259	OFFICE	CT	HD	FT	FT				
260	OFFICE	CT	HD	FT	FT				
261	OFFICE	CT	HD	FT	FT				
262	OFFICE	CT	HD	FT	FT				
263	OFFICE	CT	HD	FT	FT				
264	OFFICE	CT	HD	FT	FT				
265	OFFICE	CT	HD	FT	FT				
266	OFFICE	CT	HD	FT	FT				
267	OFFICE	CT	HD	FT	FT				
268	OFFICE	CT	HD	FT	FT				
269	OFFICE	CT	HD	FT	FT				
270	OFFICE	CT	HD	FT	FT				
271	OFFICE	CT	HD	FT	FT				
272	OFFICE	CT	HD	FT	FT				
273	OFFICE	CT	HD	FT	FT				
274	OFFICE	CT	HD	FT	FT				
275	OFFICE	CT	HD	FT	FT				
276	OFFICE	CT	HD	FT	FT				
277	OFFICE	CT	HD	FT	FT				
278	OFFICE	CT	HD	FT	FT				
279	OFFICE	CT	HD	FT	FT				
280	OFFICE	CT	HD	FT	FT				
281	OFFICE	CT	HD	FT	FT				
282	OFFICE	CT	HD	FT	FT				
283	OFFICE	CT	HD	FT	FT				
284	OFFICE	CT	HD	FT	FT				
285	OFFICE	CT	HD	FT	FT				
286	OFFICE	CT	HD	FT	FT				
287	OFFICE	CT	HD	FT	FT				
288	OFFICE	CT	HD	FT	FT				
289	OFFICE	CT	HD	FT	FT				
290	OFFICE	CT	HD	FT	FT				
291	OFFICE	CT	HD	FT	FT				
292	OFFICE	CT	HD	FT	FT				
293	OFFICE	CT	HD	FT	FT				
294	OFFICE	CT	HD	FT	FT				
295	OFFICE	CT	HD	FT	FT				
296	OFFICE	CT	HD	FT	FT				
297	OFFICE	CT	HD	FT	FT				
298	OFFICE	CT	HD	FT	FT				
299	OFFICE	CT	HD	FT	FT				
300	OFFICE	CT	HD	FT	FT				
301	OFFICE	CT	HD	FT	FT				
302	OFFICE	CT	HD	FT	FT				
303	OFFICE	CT	HD	FT	FT				
304	OFFICE	CT	HD	FT	FT				
305	OFFICE	CT	HD	FT	FT				
306	OFFICE	CT	HD	FT	FT				
307	OFFICE	CT	HD	FT	FT				
308	OFFICE	CT	HD	FT	FT				
309	OFFICE	CT	HD	FT	FT				
310	OFFICE	CT	HD	FT	FT				
311	OFFICE	CT	HD	FT	FT				
312	OFFICE	CT	HD	FT	FT				
313	OFFICE	CT	HD	FT	FT				
314	OFFICE	CT	HD	FT	FT				
315	OFFICE	CT	HD	FT	FT				
316	OFFICE	CT	HD	FT	FT				
317	OFFICE	CT	HD	FT	FT				
318	OFFICE	CT	HD	FT	FT				
319	OFFICE	CT	HD	FT	FT				
320	OFFICE	CT	HD	FT	FT				
321	OFFICE	CT	HD	FT	FT				
322	OFFICE	CT	HD	FT	FT				
323	OFFICE	CT	HD	FT	FT				
324	OFFICE	CT	HD	FT	FT				
325	OFFICE	CT	HD	FT	FT				
326	OFFICE	CT	HD	FT	FT				
327	OFFICE	CT	HD	FT	FT				
328	OFFICE	CT	HD	FT	FT				
329	OFFICE	CT	HD	FT	FT				
330	OFFICE	CT	HD	FT	FT				
331	OFFICE	CT	HD	FT	FT				
332	OFFICE	CT	HD	FT	FT				
333	OFFICE	CT	HD	FT	FT				
334	OFFICE	CT	HD	FT	FT				
335	OFFICE	CT	HD	FT	FT				
336	OFFICE	CT	HD	FT	FT				
337	OFFICE	CT	HD	FT	FT				
338	OFFICE	CT	HD	FT	FT				
339	OFFICE	CT	HD	FT	FT				
340	OFFICE	CT	HD	FT	FT				
341	OFFICE	CT	HD	FT	FT				
342	OFFICE	CT	HD	FT	FT				
343	OFFICE	CT	HD	FT	FT				
344	OFFICE	CT	HD	FT	FT				
345	OFFICE	CT	HD	FT	FT				
346	OFFICE	CT	HD	FT	FT				
347	OFFICE	CT	HD	FT	FT				
348	OFFICE	CT	HD	FT	FT				
349	OFFICE	CT	HD	FT	FT				
350	OFFICE	CT	HD	FT	FT				
351	OFFICE	CT	HD	FT	FT				
352	OFFICE	CT	HD	FT	FT				
353	OFFICE	CT	HD	FT	FT				
354	OFFICE	CT	HD	FT	FT				
355	OFFICE	CT	HD	FT	FT				
356	OFFICE	CT	HD	FT	FT				
357	OFFICE	CT	HD	FT	FT				
358	OFFICE	CT	HD	FT	FT				
359	OFFICE	CT	HD	FT	FT				
360	OFFICE	CT	HD	FT	FT				
361	OFFICE	CT	HD	FT	FT				
362	OFFICE	CT	HD	FT	FT				
363	OFFICE	CT	HD	FT	FT				
364	OFFICE	CT	HD	FT	FT				
365	OFFICE	CT	HD	FT	FT				
366	OFFICE	CT	HD	FT	FT				
367	OFFICE	CT	HD	FT	FT				
368	OFFICE	CT	HD	FT	FT				
369	OFFICE	CT	HD	FT	FT				
370	OFFICE	CT	HD	FT	FT				
371	OFFICE	CT	HD	FT	FT				
372	OFFICE	CT	HD	FT	FT				
373	OFFICE	CT	HD	FT	FT				
374	OFFICE	CT	HD	FT	FT				
375	OFFICE	CT	HD	FT	FT				
376	OFFICE	CT	HD	FT	FT				
377	OFFICE	CT	HD	FT	FT				
378	OFFICE	CT	HD	FT	FT				
379	OFFICE	CT	HD	FT	FT				
380	OFFICE	CT	HD	FT	FT				
381	OFFICE	CT	HD	FT	FT				
382	OFFICE	CT	HD	FT	FT				
383	OFFICE	CT	HD	FT	FT				
384	OFFICE	CT	HD	FT	FT				
385	OFFICE	CT	HD	FT	FT				
386	OFFICE	CT	HD	FT	FT				
387	OFFICE	CT	HD	FT	FT				
388	OFFICE	CT	HD	FT	FT				
389	OFFICE	CT	HD	FT	FT				
390	OFFICE	CT	HD	FT	FT				
391	OFFICE	CT	HD	FT	FT				
392	OFFICE	CT	HD	FT	FT				
393	OFFICE	CT	HD	FT	FT				
394									