

SEISMIC SYSTEM / LOADING DATA :

SEISMIC SYSTEM/LOADING DATA:
 NEW ADDITION: 2 STOREY ADDITION
 SEISMIC FORCE RESISTING SYSTEM (SFRS)
 SFRS: SYSTEM & CONNECTIONS: (2012 OBC CLAUSE 4.1.8.9/4.1.8.10)
 LATERAL LOAD RESISTING SYSTEM: CONVENTIONAL CONSTRUCTION (REINFORCED MASONRY SHEARWALLS)
 Rd = 1.5
 Ro = 1.5
 CSA STANDARD: CAN/CSA S304.1-04
 APPLICABLE CLAUSE(S): 4.6.3
 SFRS: DIAPHRAGMS & CONNECTIONS: (2012 OBC CLAUSE 4.1.8.15)
 CSA STANDARD: CAN/CSA S16-09
 APPLICABLE CLAUSE(S): 27.11.1 (b)
 SFRS: SYSTEM FOUNDATIONS: (2012 OBC CLAUSE 4.1.8.16)
 CSA STANDARD: CAN/CSA A23.3-04
 APPLICABLE CLAUSE(S): 21.11 FOR ANCHORED FOOTINGS
 FOR UNANCHORED FOOTINGS
 CONFIRMATION: FOUNDATIONS HAVE BEEN DESIGNED TO RESIST THE LATERAL LOAD CAPACITY OF THE SFRS INCLUDING ALL APPLICABLE AMPLIFICATION FACTORS

SEISMIC IMPORTANCE FACTOR: (2012 OBC CLAUSE 4.1.8.5)
 Ie = 1.0
 PROJECT CITY: OTTAWA (CITY HALL)
 SITE CLASS: THE NOTED SITE CLASSIFICATION FOR SEISMIC SITE RESPONSE AND SHEAR WAVE VELOCITY PARAMETERS INDICATED ARE AS REPORTED IN THE GEOTECHNICAL REPORT # 1525834-1000 & 1525834-01 BY GOLDER ASSOCIATES. REFER TO THE NOTED GEOTECHNICAL REPORT FOR Vs, N60, AND/OR Su VALUES USED TO DETERMINE SITE CLASSIFICATION.
 A B C D E F (SITE SPECIFIC SPECTRUM: OTTAWA, CITY HALL)
 PGA: 0.32
 RESPONSE SPECTRUM DATA:
 5% DAMPED SPECTRAL RESPONSE ACCELERATION VALUES: (2012 OBC SUPPLEMENT STANDARD SB-1)
 Sa (0.2) = 0.640
 Sa (0.5) = 0.310
 Sa (1.0) = 0.140
 Sa (2.0) = 0.046
 DESIGN SPECTRAL RESPONSE ACCELERATION VALUES (DSRAV): (2012 OBC CLAUSE 4.1.8.4)
 CLASS C: (Fa=1.0/Fv=1.0)
 S (0) = 0.64
 S (0.2) = 0.64
 S (0.5) = 0.31
 S (1.0) = 0.14
 S (2.0) = 0.046
 S (4.0) = 0.023

SYSTEM RESTRICTION VALUE: IeFaSa(0.2) = 0.64 > 0.35 YES NO
 PERIOD DATA:
 STATIC PERIOD: (2012 OBC CLAUSE 4.1.8.11(3))
 To (STATIC) NS = 0.12 sec
 To (STATIC) EW = 0.12 sec
 DESIGN PERIODS/MODE & MOMENT FACTORS: (2012 OBC CLAUSE 4.1.8.11(5))
 Sa(0.2) = 13.91 > 8.0 YES NO
 To (DESIGN) NS = 0.18 sec MV = 1.0 J = 1.0
 To (DESIGN) EW = 0.18 sec MW = 1.0 J = 1.0

DESIGN FUNDAMENTAL PERIOD BASED DSRAV:
 S(To) NS = 0.64
 S(To) EW = 0.64
 IRREGULARITY REVIEW (2012 OBC CLAUSE 4.1.8.6)
 1. VERTICAL STIFFNESS: YES NO
 2. WEIGHT: YES NO
 3. VERTICAL GEOMETRIC: YES NO
 4. IN PLANE DISCONTINUITY: YES NO
 5. OUT OF PLANE: YES NO
 6. WEAK STOREY: YES NO
 7. TORSIONAL: YES NO
 B NS > 1.55
 B EW > 1.36
 8. NON-ORTHOGONAL: YES NO
 CONCLUSION: BUILDING IS REGULAR IRREGULAR
 DYNAMIC ANALYSIS: REQUIRED NOT REQUIRED
 DYNAMIC PROCEDURE METHOD: MODAL RESPONSE SPECTRUM NUMERICAL INTEGRATION TIME HISTORY N/A

TORSIONAL ECCENTRICITY: ± 0.10 Dnx (4.1.8.11(10a), B ≤ 1.7 EQUIV. STATIC FORCE PROCEDURE)
 ± 0.10 Dnx (4.1.8.12(4a), B ≥ 1.7)
 ± 0.05 Dnx (4.1.8.12(4b), B < 1.7, 3-D DYNAMIC ANALYSIS)

STRUCTURAL SEPARATION: THE NEW AND EXISTING STRUCTURES HAVE BEEN SEPARATED IN ACCORDANCE WITH 4.1.8.14(1) OF THE 2012 O.B.C.
 N/A

BASE SHEARS/MOMENTS: (2012 OBC CLAUSE 4.1.8.11)
 Vstatic = S(To)MvieW/(RdRo) = 531 kN W = 1865 kN

STATIC MAXIMUM/MINIMUM VALUES:
 NORTH-SOUTH: (I)
 Vmin = S(2.0)MvieW/(RdRo) = 38 kN W = 1865 kN
 Vmax = 2/3 S(0.2)IeW/(RdRo) = 355 kN W = 1865 kN

EAST-WEST: (→)
 Vmin = S(2.0)MvieW/(RdRo) = 38 kN W = 1865 kN
 Vmax = 2/3 S(0.2)IeW/(RdRo) = 355 kN W = 1865 kN

WIND UPLIFT
 (REF FIG 1-9 NBC 2010 STRUCTURAL COMMENTARY I)
 PNET = 1.4 (pe-pi) - 0.9 D
 Pe = Iw q Ce Cp Cg Pf = 1.4 Pw NET - 0.9 Pd
 Pi = Iw q Ce Cp Cgi Pw NET = Pe - Pi
 z = 1.0 m Pw NET INTERIOR = 1.00 kPa
 Pw NET PERIMETER = 1.14 kPa

DESIGN SNOW LOAD PARAMETERS
 OTTAWA (CITY HALL), ONTARIO, CANADA
 S = Is [Sa(CbCwCsCo)+Sr]
 Ss = 2.4 kPa
 Sr = 0.4 kPa
 Is = 1.00
 S = 1.00 [2.4(0.8x1.0x1.0x1.0)+0.4]
 S = 2.32 kPa

WIND
 q = 0.41 kPa
 Iw (uls) = 1.00 Iw (sls) = 0.75
 Ce = VARIES FROM 0.9 TO 1.0
 CpCg = 1.3 OR 1.95
 N.S (I) E.W (→) UNITS
 VBASE 93 31 KN
 MBASE 512 171 KN.m

GENERAL NOTES

- ANY DEVIATION FROM THE CONDITIONS SHOWN ON THESE DRAWINGS MUST BE REPORTED TO THE ENGINEER.
- THIS STRUCTURE HAS BEEN DESIGNED IN ACCORDANCE WITH THE REQUIREMENTS OF PART 4 OF THE O.B.C. (2012 EDITION) ONTARIO REGULATION 332/12 (AS AMENDED)
- STANDARDS
 -CSA STANDARD A23.3-04 DESIGN OF CONCRETE STRUCTURES
 -CAN/CSA-S16-09 LIMIT STATES DESIGNS OF STEEL STRUCTURES
 -CSA STANDARD S304.1-04 DESIGN OF MASONRY STRUCTURES
 -CAN/CSA-086-09 ENGINEERING DESIGN IN WOOD
- ANY MODIFICATIONS TO EXISTING STRUCTURES ARE TO BE LIMITED TO WORK NOTED ON THESE DRAWINGS. ANY ADDITIONAL OR PROPOSED MODIFICATIONS TO EXISTING STRUCTURES MUST BE APPROVED BY THE ENGINEER
- FOUNDATIONS
 1. ALL FOUNDATIONS ARE TO BEAR ON SOUND ROCK OR LEAN MIX MASS CONCRETE ON ROCK OR EXISTING FOOTING ON ROCK.
 2. UNLESS NOTED OTHERWISE, THE BEARING CAPACITY USED IN THE FOUNDATION DESIGN IS ASSUMED TO BE: SLS= 500 kPa & ULS = 1000 kPa
 3. BEARING SURFACE IS TO BE INSPECTED BY GEOTECHNICAL ENGINEER PRIOR TO PLACING CONCRETE.
 4. FOR FURTHER INFORMATION SEE GEOTECHNICAL REPORT # 1525834-1000 & 1525834-01 BY GOLDER ASSOCIATES.
- SLABS ON GRADE
 1. SLABS ON GRADE TO BE UNREINFORCED UNLESS NOTED.
 2. FOR COMPOSITION & COMPACTION OF FILL SUPPORTING SLABS ON GRADE SEE GEOTECHNICAL REPORT.
 3. PROVIDE 12 mm ASPHALT IMPREGNATED FIBREBOARD BETWEEN SLABS ON GRADE & FOUNDATION WALLS OR COLUMNS
 4. SAWCUT SLAB ON GRADE TO (1/4 x SLAB DEPTH) 8 HOURS AFTER CONCRETE PLACEMENT.
 5. SPACE SAWCUTS ON A 4500 mm x 4500 mm MAXIMUM GRID. AVOID LONG & NARROW SAWCUT PATTERNS. LOCATE SAWCUTS ALONG COLUMN LINES WHERE POSSIBLE. CONTRACTOR IS TO PROVIDE THE ENGINEER WITH DOCUMENTATION SHOWING PROPOSED SAWCUT LOCATIONS FOR APPROVAL UNLESS SAWCUTS LOCATIONS ARE OTHERWISE INDICATED ON THESE DRAWINGS.
- MATERIALS
 1. CONCRETE STRENGTH AT 28 DAYS TO BE AS NOTED ON PLANS AND IN SPECIFICATIONS
 2. REINFORCING STEEL TO BE DEFORMED GRADE 400R WITH Fy= 400 MPa.
 3. HOLLOW STRUCTURAL STEEL SECTIONS TO BE ASTM A500 GRADE C OR G40.21 350W CLASS C.
 4. ALL "W" SHAPE STEEL SECTIONS TO BE GRADE G40.21 350W WITH Fy= 350 MPa.
 5. ALL OTHER STRUCTURAL STEEL TO BE GRADE G40.21 300W WITH Fy= 300 MPa UNLESS NOTED OTHERWISE.
 6. ALL STRUCTURAL STEEL TO RECEIVE 1 SHOP APPLIED COAT OF PRIMER UNLESS NOTED.
 7. ALL STRUCTURAL STEEL EXPOSED TO EXTERIOR IS TO BE HOT DIP GALVANIZED UNLESS NOTED.
 8. ANCHOR BOLTS TO BE A307.
 9. ALL OTHER BOLTS TO BE A325.
 10. A325 BOLTS EXPOSED TO EXTERIOR ARE TO BE STAINLESS STEEL
 11. A307 BOLTS EXPOSED TO EXTERIOR ARE TO BE GALVANIZED.
 12. CONCRETE BLOCK TO BE H/15/A/M
 13. CONCRETE BLOCK MASONRY MORTAR TO BE 8.5 MPa TYPE 'S' U/N
 14. CONCRETE BLOCK MASONRY GROUT TO BE 12 MPa "HIGH SLUMP" (200-250 mm SLUMP)
- REINFORCING STEEL DESIGNATION
 8-20M x 1500 T/B
 8 = NUMBER OF BARS
 20M = SIZE OF BARS
 1500 = LENGTH OF BARS
 T = BAR LOCATION- TOP
 B = BAR LOCATION- BOT
 LENGTH OF BARS DOES NOT INCLUDE HOOKS OR BENDS
- CONCRETE COVER
 1. GRADE BEAMS 75 mm BOTTOM
 50 mm TOP & SIDES
 2. FOUNDATION WALLS 40 mm UNLESS NOTED OTHERWISE
- DOWELS
 DOWELS TO GRADE BEAMS TO BE OF SAME DIAMETER AS THE LOWEST LIFT OF VERTICAL REINFORCING IN PIERS OR WALLS.
- REINFORCING STEEL SPLICES
 REINFORCING STEEL SPLICES TO BE AS NOTED IN REINFORCING BAR LAP LENGTH TABLE ON S01 U/N.
- LOADS
 ALL LOADS & FORCES INDICATED ON THESE DRAWINGS ARE UNFACTORED WORKING LOADS UNLESS NOTED.
- CONCRETE BLOCK MASONRY UNLESS NOTED OTHERWISE
 1. 140 mm CONCRETE BLOCK:
 VERT: 1-15M @ 800 o/c
 HORIZ: SL2 @ 200 o/c OR HL2 @ 400 o/c
 2. 190 mm CONCRETE BLOCK
 VERT: 1-15M @ 800 o/c
 HORIZ: HL2 @ 200 o/c
 3. 240 mm CONCRETE BLOCK
 VERT: 1-20M @ 800 o/c
 HORIZ: HL2 @ 200 o/c
- LEGEND
 H-HEAVY 5 mm LONGITUDINAL WIRES
 9 GAUGE CROSS WIRES
 L- LADDER TYPE REINFORCEMENT
 2-2 LONGITUDINAL WIRES
 5. SEE ARCHITECTURAL DRAWINGS AND SPECIFICATIONS FOR TYPING MASONRY TO BACK UP WALLS.
 6. SPECIAL WALLS - SEE NOTES ON PLANS & SCHEDULE FOR REINFORCING AND GROUTING OTHER THAN INDICATED ABOVE
 7. REINFORCE CELLS @ END OF WALLS AT INTERSECTING WALLS & BESIDE OPENINGS.
 8. GROUT MASONRY SOLID BELOW BEARING BASE PLATES FOR 500mm MIN.
 9. PROVIDE "CLEAN OUTS" AT BOTTOM OF CELLS TO BE GROUTED TO ENSURE PROPER LAP LENGTH AND THAT CELL IS FILLED SOLIDLY. MAXIMUM GROUT LIFT IS 3 metres. GROUT TO HAVE 250mm SLUMP.
 10. EMBEDMENT OF MASONRY DOWELS IN CONCRETE STRUCTURE BELOW CONCRETE BLOCK WALLS TO BE AS FOLLOWS:
 15M DOWELS = 600 mm EMBEDMENT - 1300 Lg. DOWEL
 20M DOWELS = 800 mm EMBEDMENT - 1700 Lg. DOWEL
 11. BLOCK CONTROL JOINT SPACED AT 9000 mm MAXIMUM VENEER CONTROL JOINT SPACED AT 12000 mm MAXIMUM COORDINATE LOCATION OF JOINTS WITH ARCHITECT & ENGINEER
- LEGEND
 B = BOTTOM
 B1 = BOTTOM LOWER LAYER
 B2 = BOTTOM UPPER LAYER
 BLL = BOTTOM LOWER LAYER
 BUL = BOTTOM UPPER LAYER
 BP1 = BEAM BEARING PLATE NUMBER
 BP1 = BASE PLATE NUMBER
 BUL = BOTTOM UPPER LAYER
 DP = DEPTH
 EF = EACH FACE
 EL = ELEVATION
 ES = EACH SIDE
 EW = EACH WAY
 (ex) = EXISTING
 GB = GRADE BEAM
 H = HORIZONTAL
 (H) = HOOKED BAR
 O/C = ON CENTER
 SC1 = STEEL COLUMN NUMBER
 T = TOP
 T1 = TOP UPPER LAYER
 T2 = TOP LOWER LAYER
 TLL = TOP LOWER LAYER
 TUL = TOP UPPER LAYER
 U/N = UNLESS NOTED OTHERWISE
 V = VERTICAL

DESIGN & DETAILING CRITERIA FOR SUPPLIERS

- MISCELLANEOUS METALS & STEEL STAIRS
 MISC METALS & STEEL STAIRS ARE TO BE DESIGNED AND DETAILED BY MISC METALS & STEEL STAIRS SUPPLIER. SHOP DRAWINGS ARE TO BE SUBMITTED TO DESIGN TEAM FOR REVIEW. SHOP DRAWINGS ARE TO BE STAMPED AND SIGNED BY A PROFESSIONAL ENGINEER LICENSED IN THE PROVINCE OF ONTARIO. ALL MISC METAL & STEEL STAIR WORK IS TO BE INSPECTED DURING CONSTRUCTION BY THE MISC METALS & STEEL STAIRS DESIGN ENGINEER.
- COLD FORMED STEEL STUDS & JOISTS
 STEEL STUDS & JOISTS ARE TO BE DESIGNED AND DETAILED BY STEEL STUDS & JOISTS SUPPLIER. SHOP DRAWINGS ARE TO BE SUBMITTED TO DESIGN TEAM FOR REVIEW. SHOP DRAWINGS ARE TO BE STAMPED AND SIGNED BY A PROFESSIONAL ENGINEER LICENSED IN THE PROVINCE OF ONTARIO. ALL STEEL STUD & JOIST WORK IS TO BE INSPECTED DURING CONSTRUCTION BY THE STEEL STUD & JOIST DESIGN ENGINEER.
- STRUCTURAL STEEL CONNECTIONS
 STRUCTURAL STEEL CONNECTIONS ARE TO BE DESIGNED AND DETAILED BY STRUCTURAL STEEL SUPPLIER. SHOP DRAWINGS ARE TO BE SUBMITTED TO CUNLIFFE & ASSOCIATES FOR REVIEW. SHOP DRAWINGS ARE TO BE STAMPED AND SIGNED "FOR CONNECTIONS ONLY" BY A PROFESSIONAL ENGINEER LICENSED IN THE PROVINCE OF ONTARIO. INSPECTION OF WELDS, CONNECTIONS & INSTALLATION IS TO BE UNDERTAKEN BY A 3RD PARTY, CERTIFIED INSPECTION SERVICE.
- GUARDS & HANDRAILS
 GUARDS & HANDRAILS ARE TO BE DESIGNED AND DETAILED BY STEEL SUPPLIER. SHOP DRAWINGS ARE TO BE SUBMITTED TO DESIGN TEAM FOR REVIEW. SHOP DRAWINGS ARE TO BE STAMPED AND SIGNED BY A PROFESSIONAL ENGINEER LICENSED IN THE PROVINCE OF ONTARIO. ALL GUARDS & HANDRAIL WORK IS TO BE INSPECTED DURING CONSTRUCTION BY THE GUARD & HANDRAIL DESIGN ENGINEER.
- SEISMIC RESTRAINT OF MECH'L EQUIPMENT & PIPING
 SEISMIC RESTRAINT OF MECH'L EQUIPMENT & PIPING TO BE DETAILED BY MECH'L EQUIPMENT & PIPING SUPPLIER OR CONTRACTOR. SHOP DRAWINGS ARE TO BE SUBMITTED TO CUNLIFFE & ASSOCIATES FOR REVIEW. SHOP DRAWINGS ARE TO BE STAMPED AND SIGNED BY A PROFESSIONAL ENGINEER LICENSED IN THE PROVINCE OF ONTARIO. ALL SEISMIC RESTRAINT INSTALLATIONS ARE TO BE INSPECTED DURING CONSTRUCTION BY THE DESIGN ENGINEER OF RECORD
- CONCRETE BLOCK MASONRY WALLS-CONSTRUCTION BRACING
 ALL NON LOAD BEARING CONCRETE BLOCK MASONRY WALLS ARE TO BE LATERALLY BRACED DURING CONSTRUCTION UNTIL PERMANENT LATERAL BRACING IS INSTALLED AS PER TYPICAL DETAILS AND OR SECTIONS.
 LATERAL CONSTRUCTION BRACING DRAWINGS ARE TO BE SUBMITTED TO CUNLIFFE & ASSOCIATES FOR REVIEW. SHOP DRAWINGS ARE TO BE STAMPED AND SIGNED BY A PROFESSIONAL ENGINEER LICENSED IN THE PROVINCE OF ONTARIO.
- CURTAIN WALLS
 SUPPORTS FOR CURTAIN WALLS ARE TO BE DESIGNED AND DETAILED BY CURTAIN WALL SUPPLIER. SHOP DRAWINGS ARE TO BE SUBMITTED TO DESIGN TEAM FOR REVIEW. SHOP DRAWINGS ARE TO BE STAMPED AND SIGNED BY A PROFESSIONAL ENGINEER LICENSED IN THE PROVINCE OF ONTARIO. ALL SUPPORTS ARE TO BE INSPECTED DURING CONSTRUCTION BY THE SUPPORT DESIGN ENGINEER.
 NOTE:
 INSPECTION REPORTS CREATED AS A RESULT OF THE ABOVE NOTED WORK MUST BE SUBMITTED TO THE CONSTRUCTION MANAGER. CONSTRUCTION MANAGER IS TO PROVIDE COPIES TO THE CONSULTANTS.

DRAWING LIST

- S01 SEISMIC DATA & GENERAL NOTES
 S02 TYPICAL DETAILS
 S100 FOUNDATION PLAN
 S101 GROUND FLOOR PLAN
 S102 STORAGE ROOM PLAN
 S103 LOW ROOF PLAN
 S104 HIGH ROOF PLAN
 S200 SECTIONS
 S300 SECTIONS & DETAILS
 S301 SECTIONS & DETAILS
 S302 SECTIONS & DETAILS

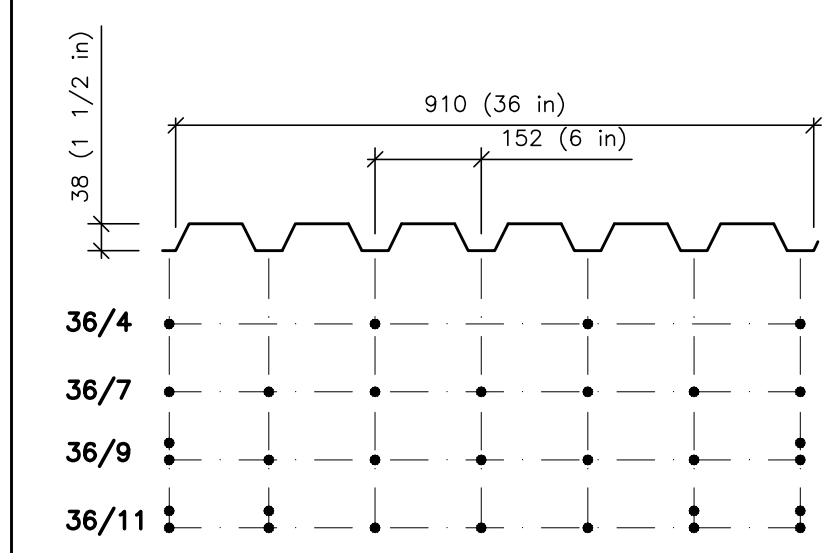

FASTENER PATTERNS @ SUPPORT FOR 38 THK STEEL DECK

STEEL DECK NOTES: TYPICAL FLOOR DECK (SEE PLAN ALSO)
 1. 38 x 0.76 COMPOSITE INTERLOCKING (CANAM OR EQUIVALENT)
 2. HILTI S-SLCO11M HHW FASTENERS IN SIDE LAPS @ 300 o/c
 3. 36/7 FASTENER PATTERN (SEE ABOVE)
 4. HILTI X-HSN24 FASTENERS TO SUPPORTING MEMBERS
 5. FASTENER SPACING AROUND PERIMETER & OPENINGS TO BE 150 o/c
 6. DECK BE 3 SPAN MINIMUM
 7. STEEL DECK IS NOT TO BE USED FOR SUPPORT OF ARCH'L MECH'L OR ELECT'L ITEMS. USE STEEL STRUCTURE FOR SUPPORT.

STEEL DECK NOTES: TYPICAL ROOF DECK (SEE PLAN ALSO)
 1. 38 x 1.21 OVERLAPPING (CANAM OR EQUIVALENT)
 2. HILTI S-SLCO11M HHW FASTENERS IN SIDE LAPS @ 150 o/c
 3. 36/11 FASTENER PATTERN (SEE ABOVE)
 4. HILTI X-HSN24 FASTENERS TO SUPPORTING MEMBERS
 5. FASTENER SPACING AROUND PERIMETER & OPENINGS TO BE 150 o/c
 6. DECK BE 3 SPAN MINIMUM
 7. STEEL DECK IS NOT TO BE USED FOR SUPPORT OF ARCH'L MECH'L OR ELECT'L ITEMS. USE STEEL STRUCTURE FOR SUPPORT.

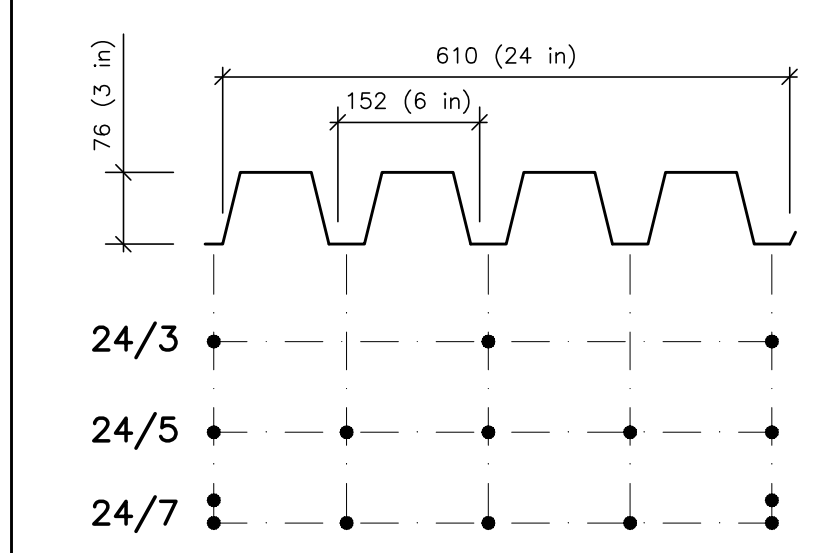

FASTENER PATTERN @ SUPPORT FOR 76 THK ACOUSTIC STEEL DECK

STEEL DECK NOTES: ACTIVITY ROOM ROOF DECK (SEE PLAN ALSO)
 1. 76 x 1.21 OVERLAPPING (CANAM OR EQUIVALENT)
 2. HILTI S-SLCO11M HHW FASTENERS IN SIDE LAPS @ 75 o/c
 3. 24/7 FASTENER PATTERN (SEE ABOVE)
 4. HILTI EMP-19 FASTENERS TO SUPPORTING MEMBERS
 5. FASTENER SPACING AROUND PERIMETER & OPENINGS TO BE 150 o/c
 6. DECK BE 3 SPAN MINIMUM
 7. STEEL DECK IS NOT TO BE USED FOR SUPPORT OF ARCH'L MECH'L OR ELECT'L ITEMS. USE STEEL STRUCTURE FOR SUPPORT.

REINFORCING BAR LAP LENGTH TABLE

CONCRETE STRENGTH (MPa)	REINFORCING BAR LAP LENGTH (mm)				
	10M	15M	20M	25M	30M
20	475	700	850	1325	1575
25	425	600	750	1200	1400
30	400	550	675	1100	1275
35	375	525	625	1000	1200

FOR SPECIAL CONDITIONS MULTIPLY THE VALUES LISTED ABOVE BY THE FOLLOWING FACTORS:
 1. EPOXY COATED REINFORCING (X 1.5)
 2. HORIZONTAL REINFORCING WITH >300 mm GROUT BELOW (X 1.3)
 3. FOR CONDITIONS 1 & 2 OCCURRING SIMULTANEOUSLY (X 1.7)

CONCRETE BLOCK MASONRY WALLS

REINFORCING BAR LAP LENGTH TABLE

HJR	REINFORCING BAR LAP LENGTH (mm)				
	10M	15M	20M	25M	30M
300	525	750	925	1450	1725

FOR SPECIAL CONDITIONS MULTIPLY THE VALUES LISTED ABOVE BY THE FOLLOWING FACTORS:
 1. EPOXY COATED REINFORCING (X 1.5)
 2. HORIZONTAL REINFORCING WITH >300 mm GROUT BELOW (X 1.3)
 3. FOR CONDITIONS 1 & 2 OCCURRING SIMULTANEOUSLY (X 1.7)

Ottawa
 DEPARTMENT OF CORPORATE SERVICES / SERVICES GÉNÉRAUX
 REAL PROPERTY ASSET MANAGEMENT BRANCH /
 DIRECTION DE LA GESTION DES ACTIFS ET DES BIENS IMMOBILIERS
 DESIGN AND CONSTRUCTION DIVISION /
 DIVISION DE LA CONCEPTION ET DE LA CONSTRUCTION
 GREG GEDES CHIEF CORPORATE SERVICES OFFICER /
 CHEF DES SERVICES GÉNÉRAUX
 S.A. FINNMORE, O.A.A. DIRECTOR / DIRECTEUR, O.A.O.
 ROBERT VAILLANCOURT, O.A.A. MANAGER / GESTIONNAIRE, O.A.O.
 FOR / POUR



CUNLIFFE
 CUNLIFFE & ASSOCIATES
 CONSULTING STRUCTURAL ENGINEERS
 102-1737 WOODWARD DR. OTTAWA ON K2C 0P9
 TEL: (613) 726-7242 FAX: (613) 726-1661
 Email: cunliffe@cunliffe.ca

DESIGNED BY / CONÇU PAR	CHECKED BY / VÉRIFIÉ PAR
JC	JC
DRAWN BY / DÉSSINÉ PAR	SCALE / ÉCHELLE
RW	NOT TO SCALE
DRAWING TITLE	
1:1 SCALE	
SHEET NUMBER	
1	

THIS DRAWING IS THE PROPERTY OF THE CITY OF OTTAWA AND ALL COPYRIGHTS ARE RESERVED. NO PART OF THIS DRAWING IS TO BE REPRODUCED OR TRANSMITTED IN ANY FORM OR BY ANY MEANS, ELECTRONIC OR MECHANICAL, INCLUDING PHOTOCOPYING, RECORDING, OR BY ANY INFORMATION STORAGE AND RETRIEVAL SYSTEM, WITHOUT THE WRITTEN PERMISSION OF THE CITY OF OTTAWA.
 CE Dessin constitue la propriété de la Ville d'Ottawa et tout droit d'auteur est réservé. Aucune partie de ce dessin ne doit être reproduite ou transmise sous quelque forme que ce soit, électronique ou mécanique, y compris la photocopie, l'enregistrement ou par tout système de stockage et de récupération d'information, sans la permission écrite de la Ville d'Ottawa.

ARCHITECT / ARCHITECTE
 CONSULTANT / EXPERT-CONSEIL
 LICENSED PROFESSIONAL ENGINEER
 2017-09-29
 R. I. CUNLIFFE
 MEMBER OF OMA
 CONSULTANT / EXPERT-CONSEIL
 CONSULTANT / EXPERT-CONSEIL

PROJECT / LOCATION / PROJET / ENDROIT

DOVERCOURT
 PHASE 2
 ADDITION & RENOVATION

411 DOVERCOURT
 OTTAWA, ONTARIO

DRAWING / DESSIN
 SEISMIC DATA &
 GENERAL NOTES

FACILITY NO. / NO. DE INSTALLATIONS SHEET NO. / FEUILLE No.

PROJECT NO. / PROJET NO.
 1713

S01

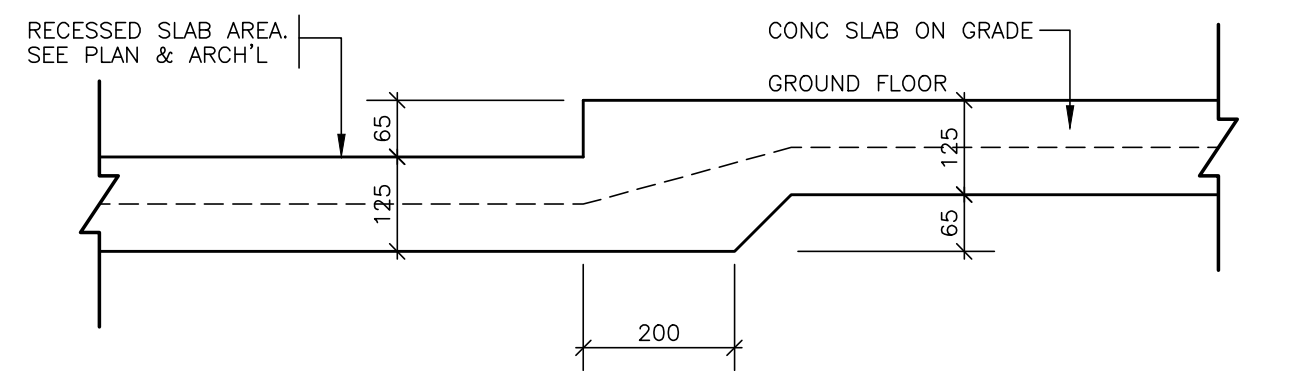

TYP. DETAIL- RECESSED SLAB ON GRADE

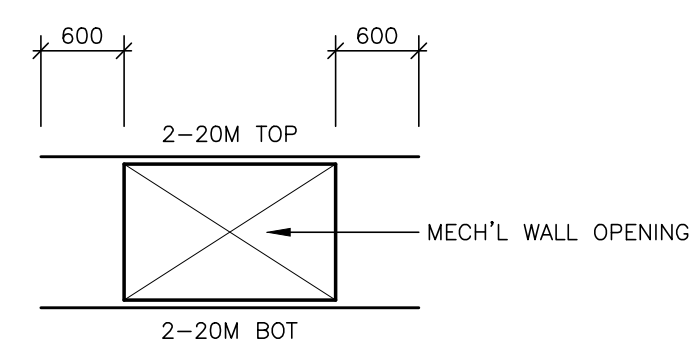

TYPICAL DETAIL AT CONCRETE WALL OPENING U/N

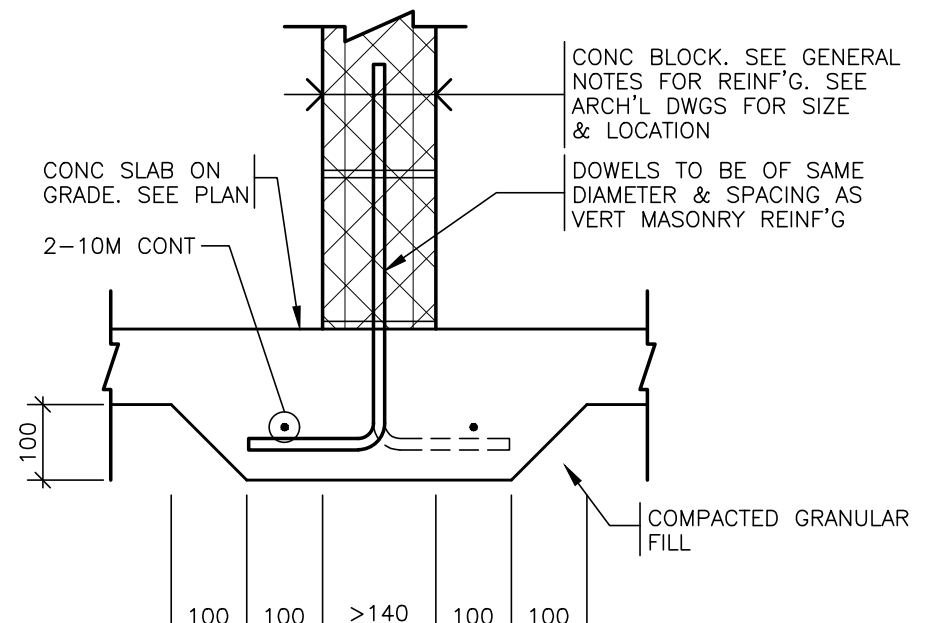

TYPICAL SLAB ON GRADE THICKENING DETAIL BELOW NON LOAD BEARING CONC BLOCK MASONRY

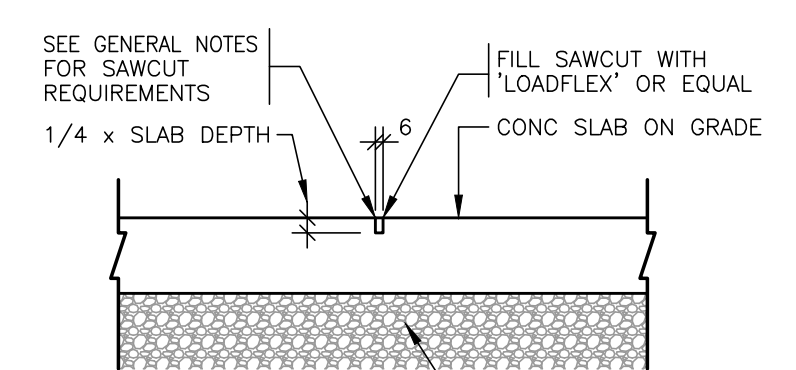

TYPICAL SAWCUT IN SLAB ON GRADE DETAIL

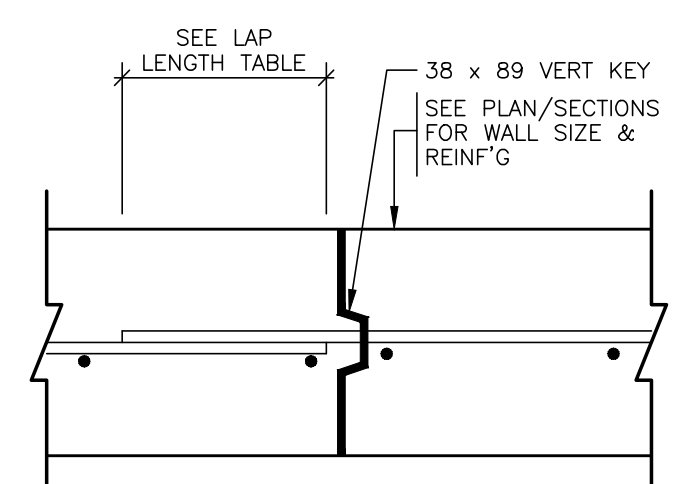

TYPICAL WALL CONSTRUCTION JOINT DETAIL
MAXIMUM SPACING OF CONSTRUCTION JOINTS TO BE 20 metres

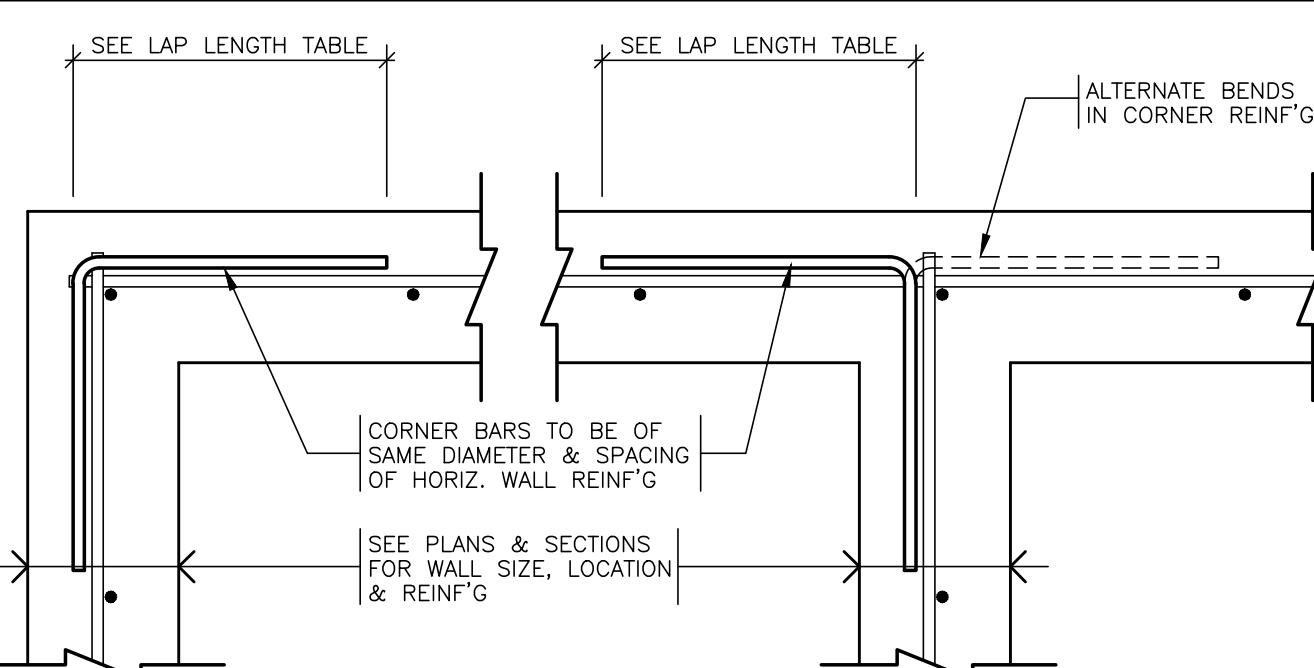

TYPICAL WALL INTERSECTION REINFORCEMENT
CONCRETE WALLS WITH 1 SHEET OF REINFORCING (WALL THICKNESS LESS THAN 215 mm) NOT APPLICABLE TO SHEARWALLS. SEE SHEARWALL ELEVATION DRAWINGS

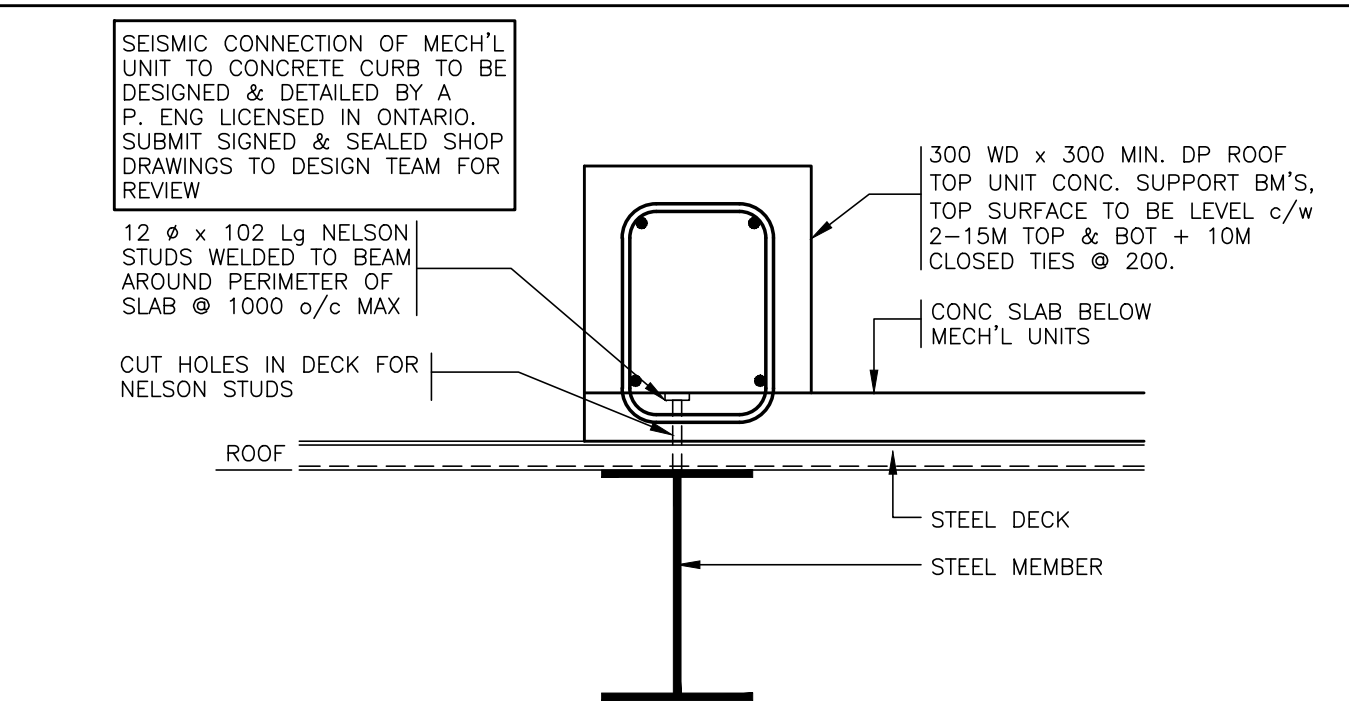

DETAIL-NELSON STUDS AT PERIMETER OF MECH'L PAD

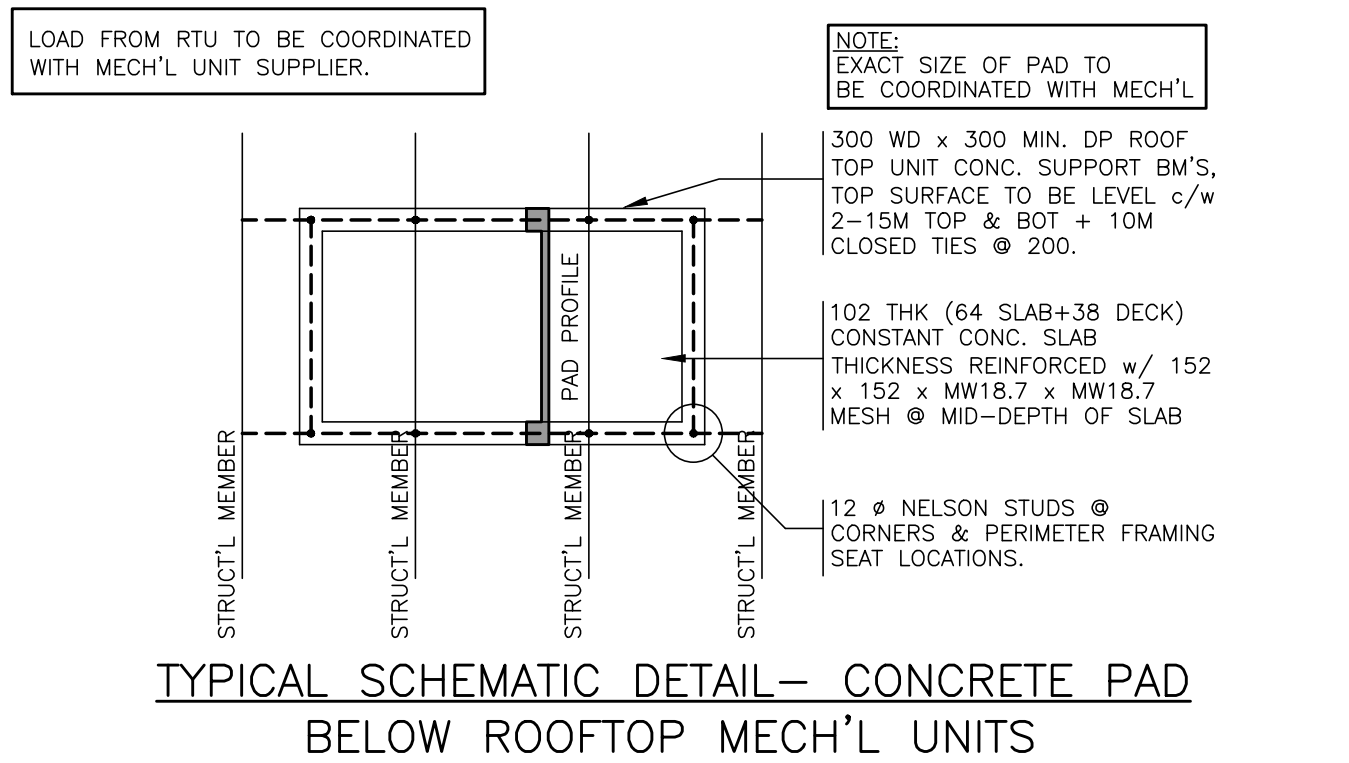

TYPICAL SCHEMATIC DETAIL- CONCRETE PAD BELOW ROOFTOP MECH'L UNITS

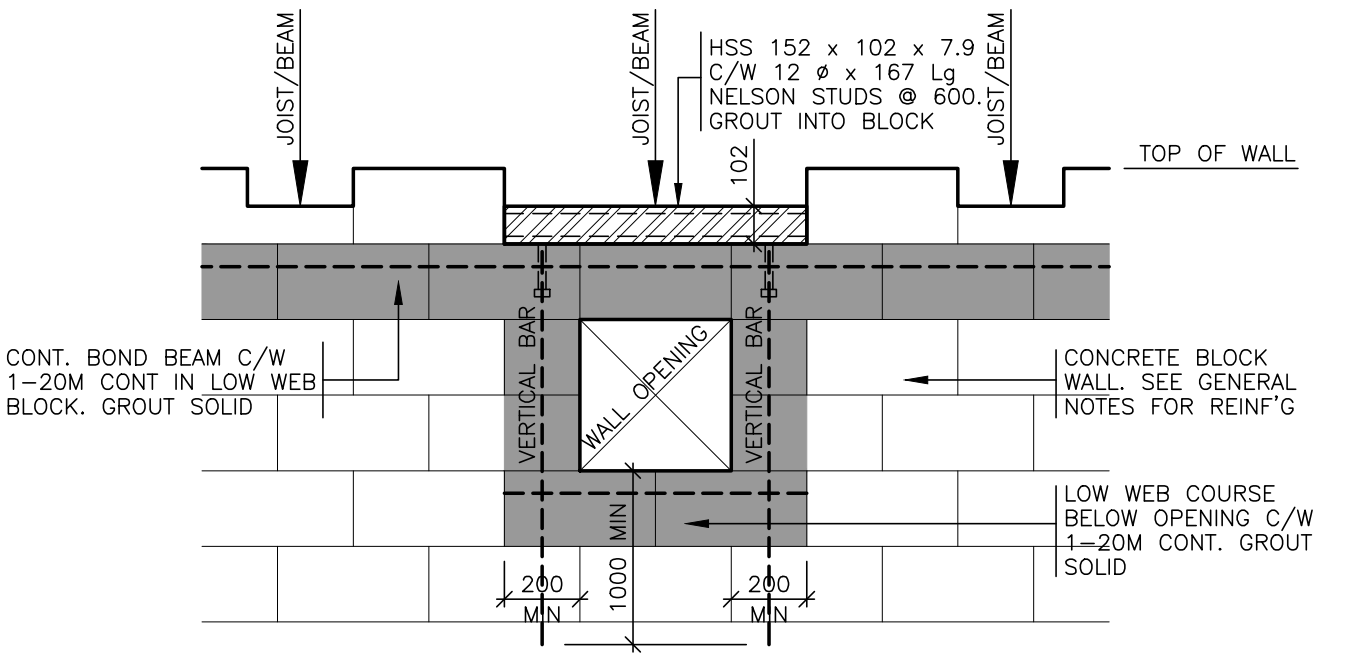

ELEVATION-MECHANICAL OPENING THRU LOAD BEARING CONCRETE BLOCK MASONRY (LOCATED BELOW JOISTS)

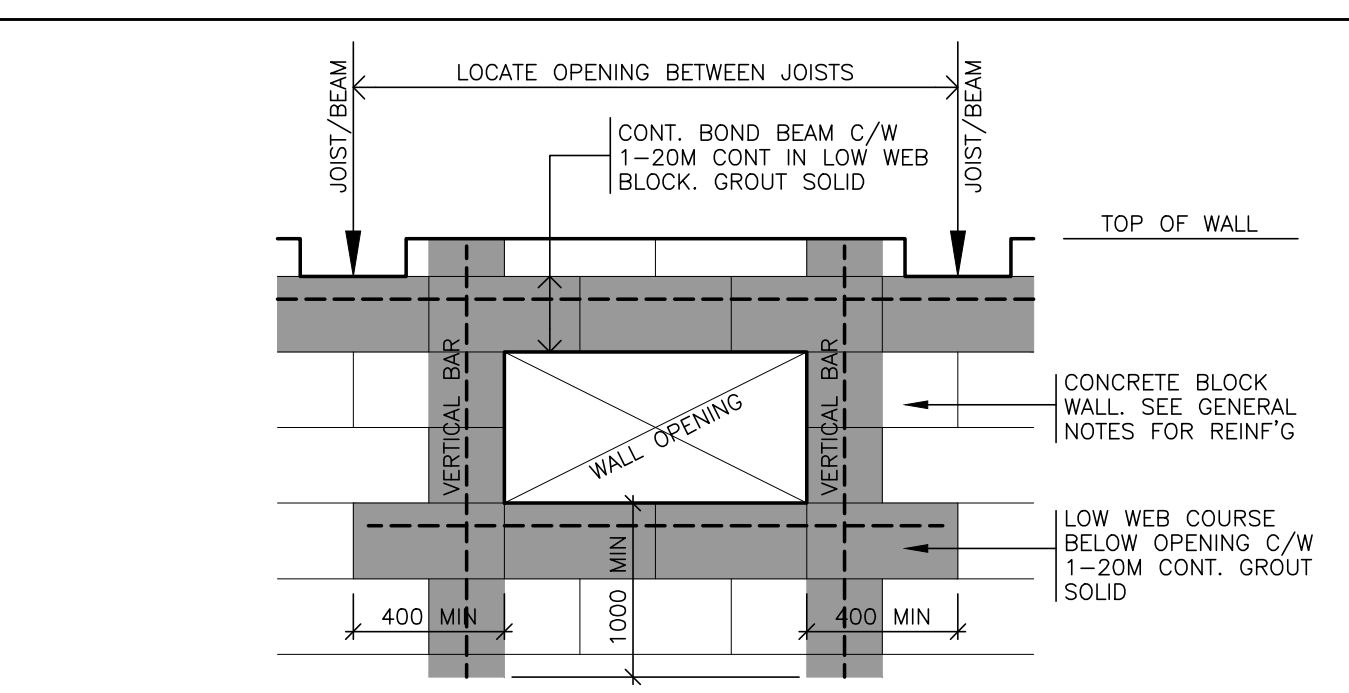

ELEVATION-MECHANICAL OPENING THRU LOAD BEARING CONCRETE BLOCK MASONRY (LOCATED BETWEEN JOISTS)

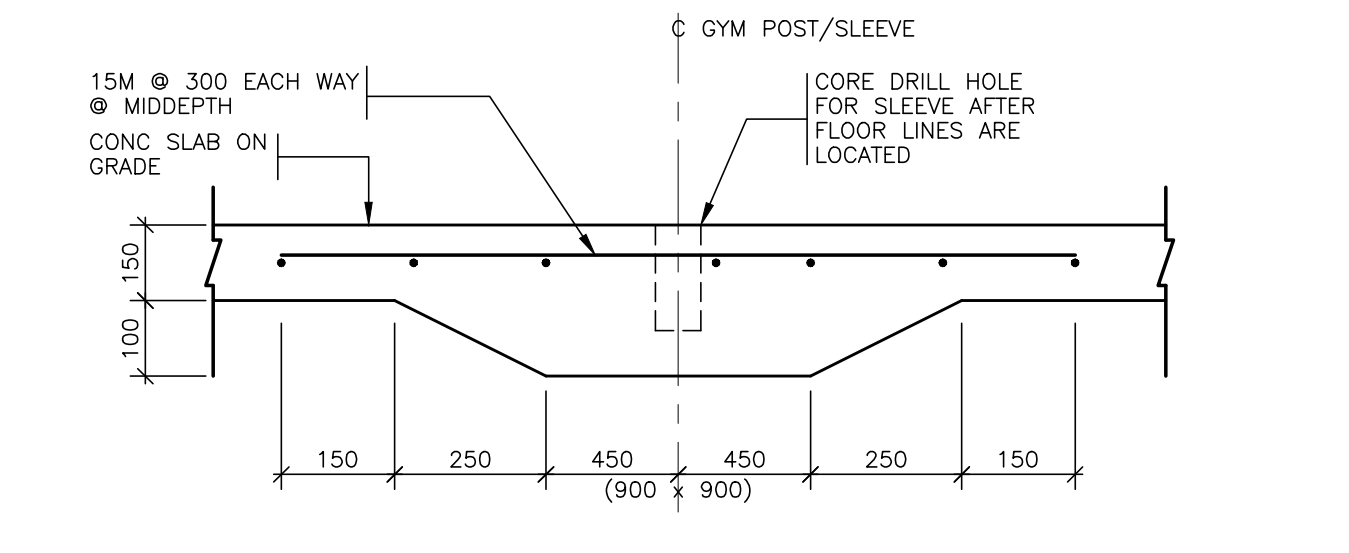

TYPICAL SLAB ON GRADE THICKENING DETAIL AT GYMNASIUM FLOOR SOCKET
COORDINATE LOCATIONS WITH ARCH'L DRAWINGS

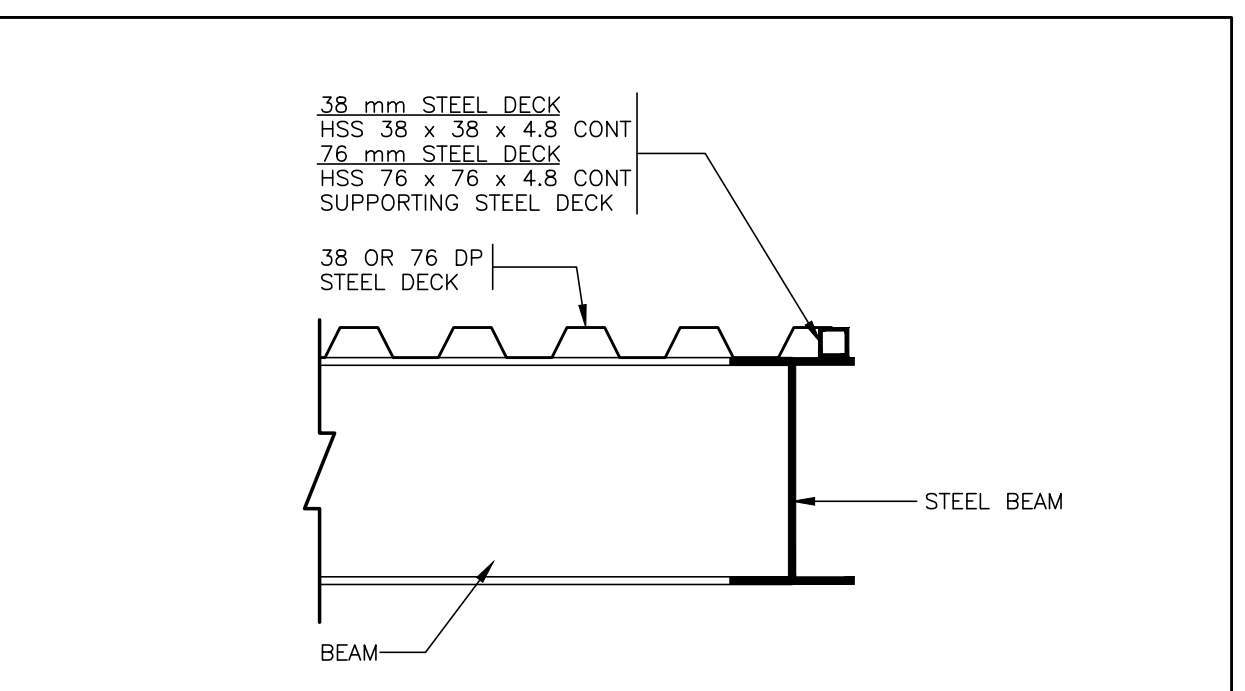

TYP. DETAIL-ALTERNATE SUPPORT OF STEEL DECK

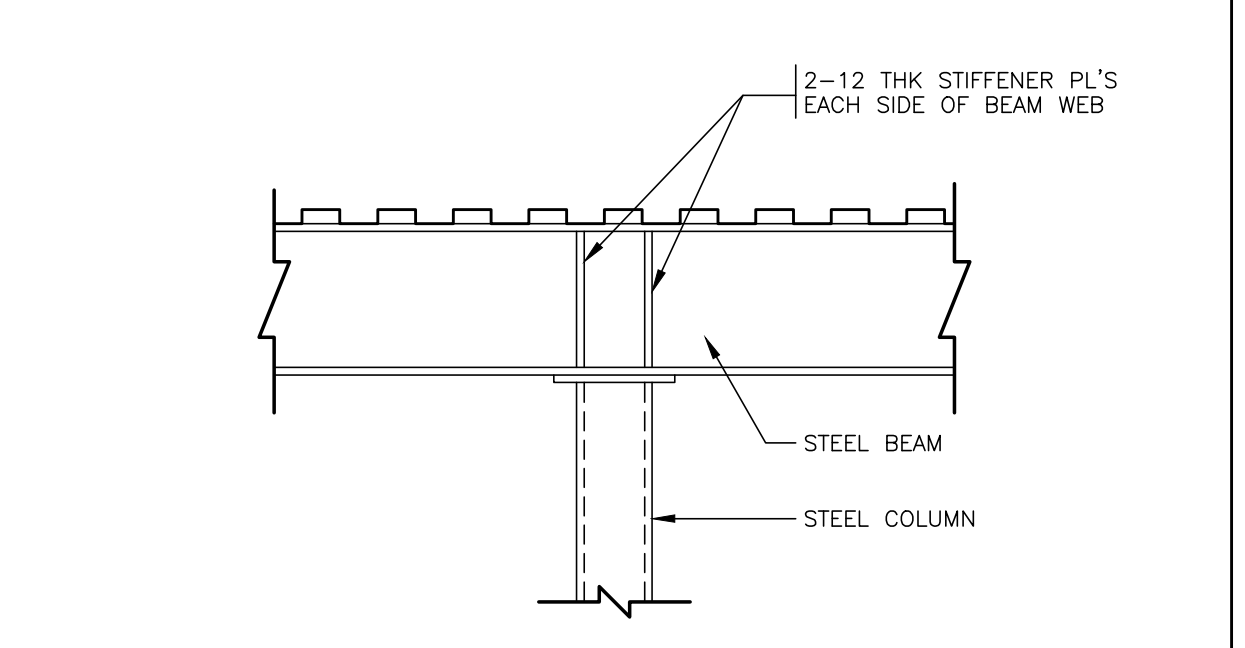

CANTILEVERED OR MULTI-SPAN BEAM DETAIL

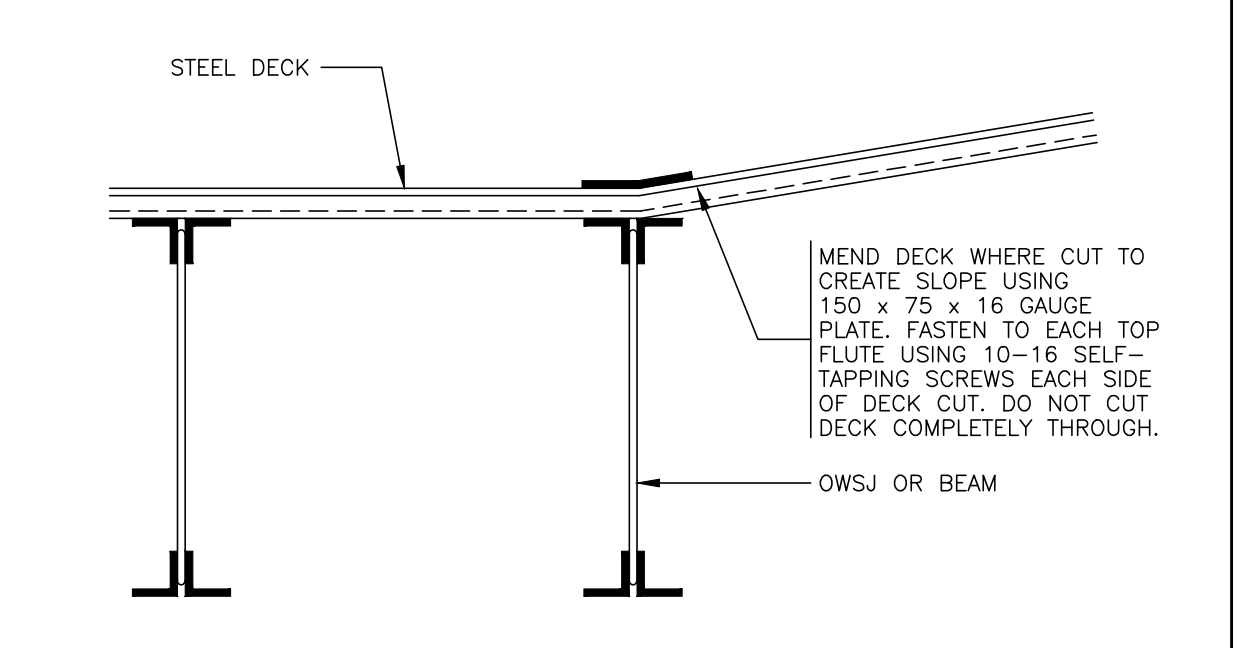

DETAIL-MENDING DECK AT CUT LINES

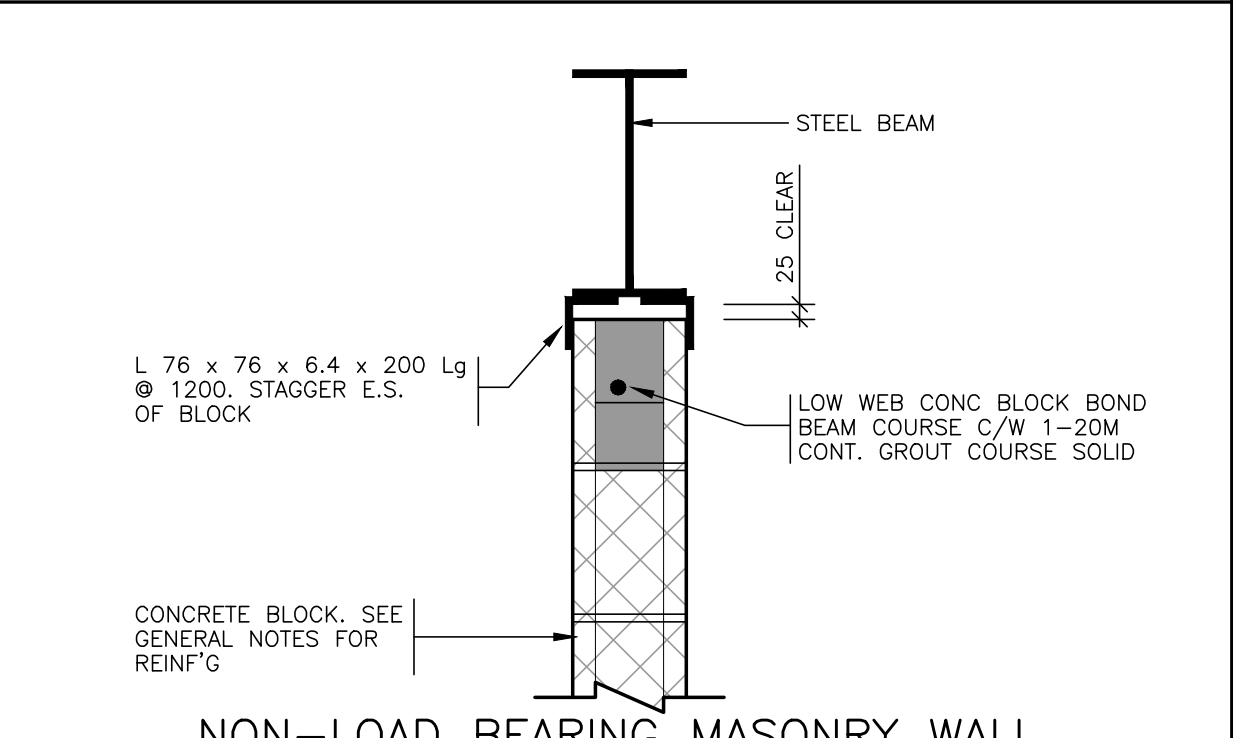

NON-LOAD BEARING MASONRY WALL LATERAL SUPPORT DETAIL UNDER STEEL BEAM

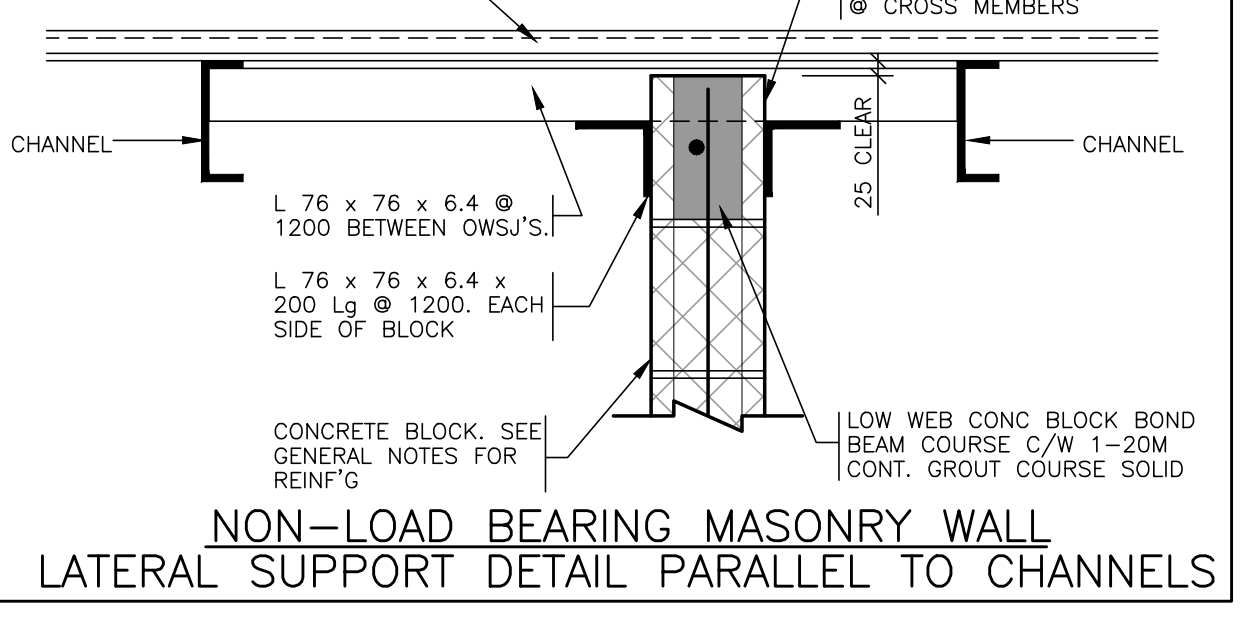

NON-LOAD BEARING MASONRY WALL LATERAL SUPPORT DETAIL PARALLEL TO CHANNELS

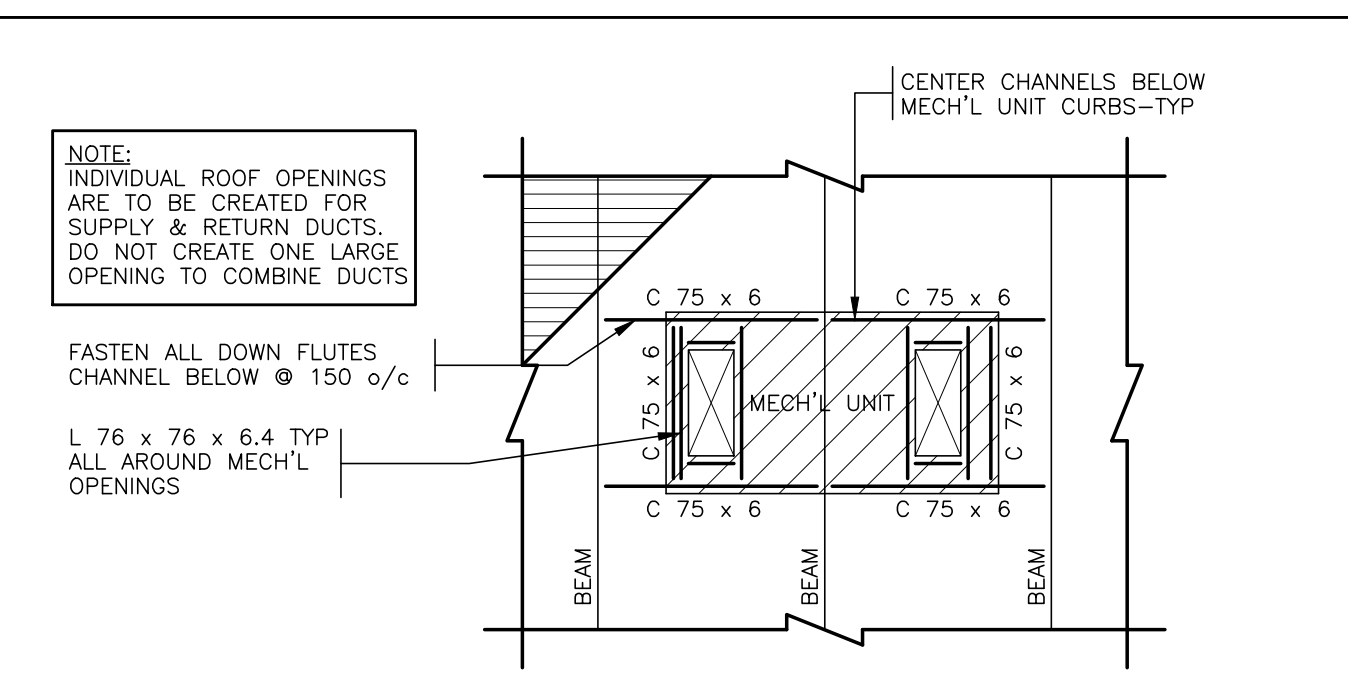

TYPICAL DETAIL- ADDITIONAL FRAMING AT ROOFTOP MECH'L UNITS (WITH UNIT OPENINGS THROUGH ROOF)

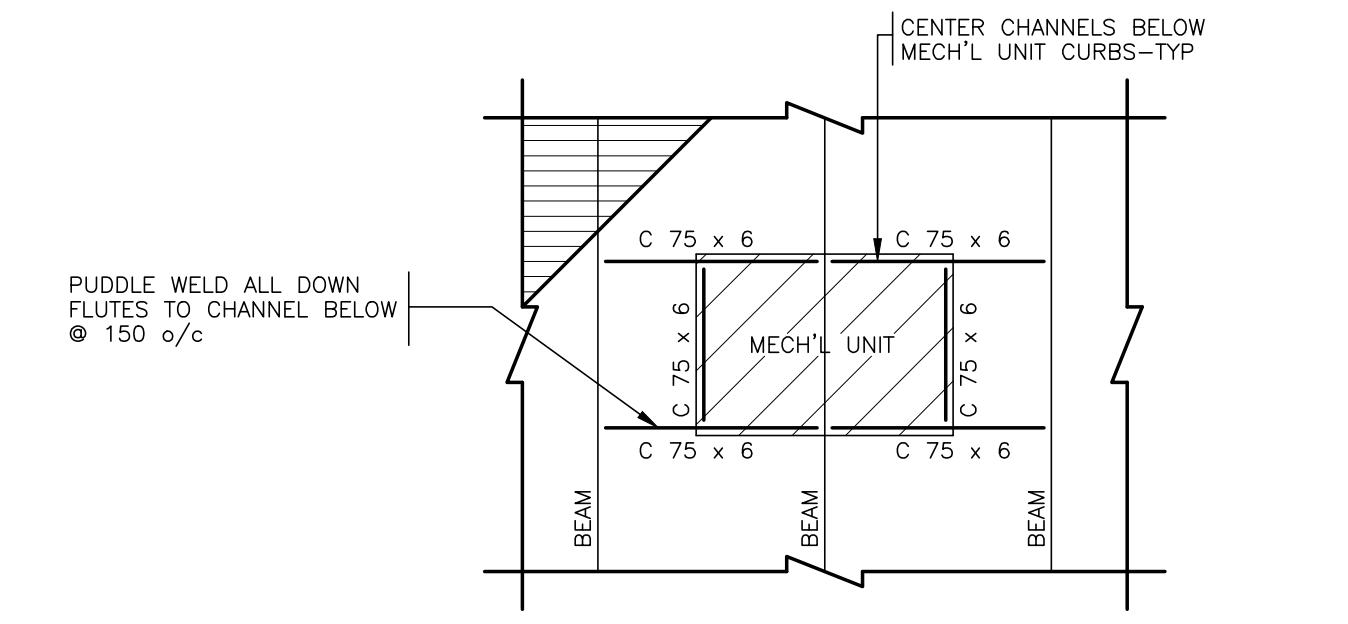

TYPICAL DETAIL- ADDITIONAL FRAMING AT ROOFTOP MECH'L UNITS (U/N ON PLAN) (NO UNIT OPENINGS THROUGH ROOF)

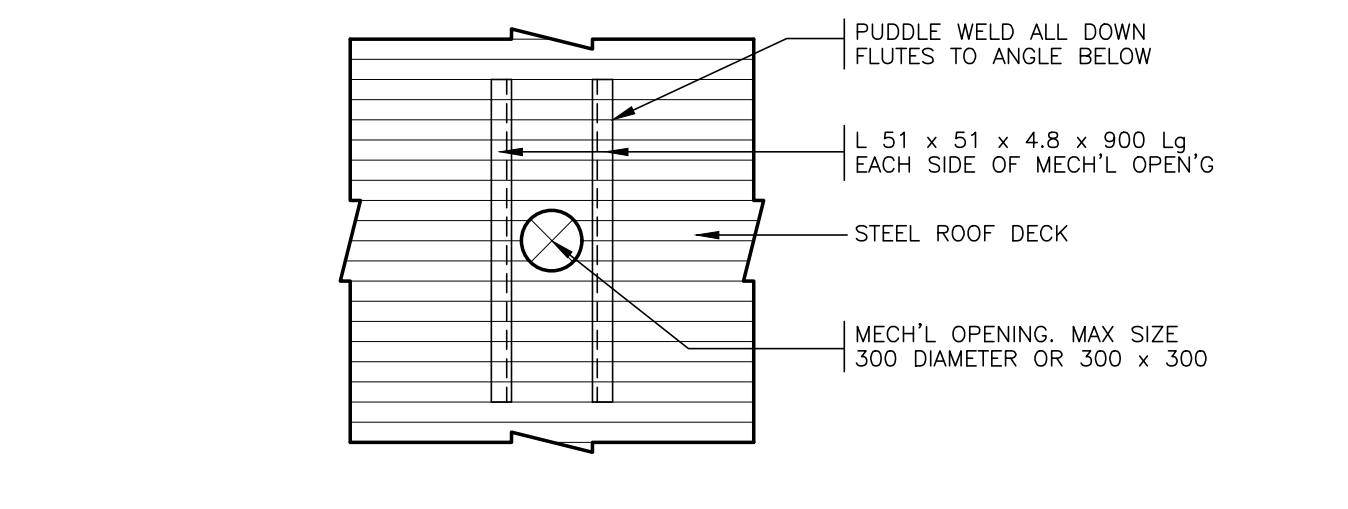

PLAN DETAIL-MECHANICAL OPENINGS

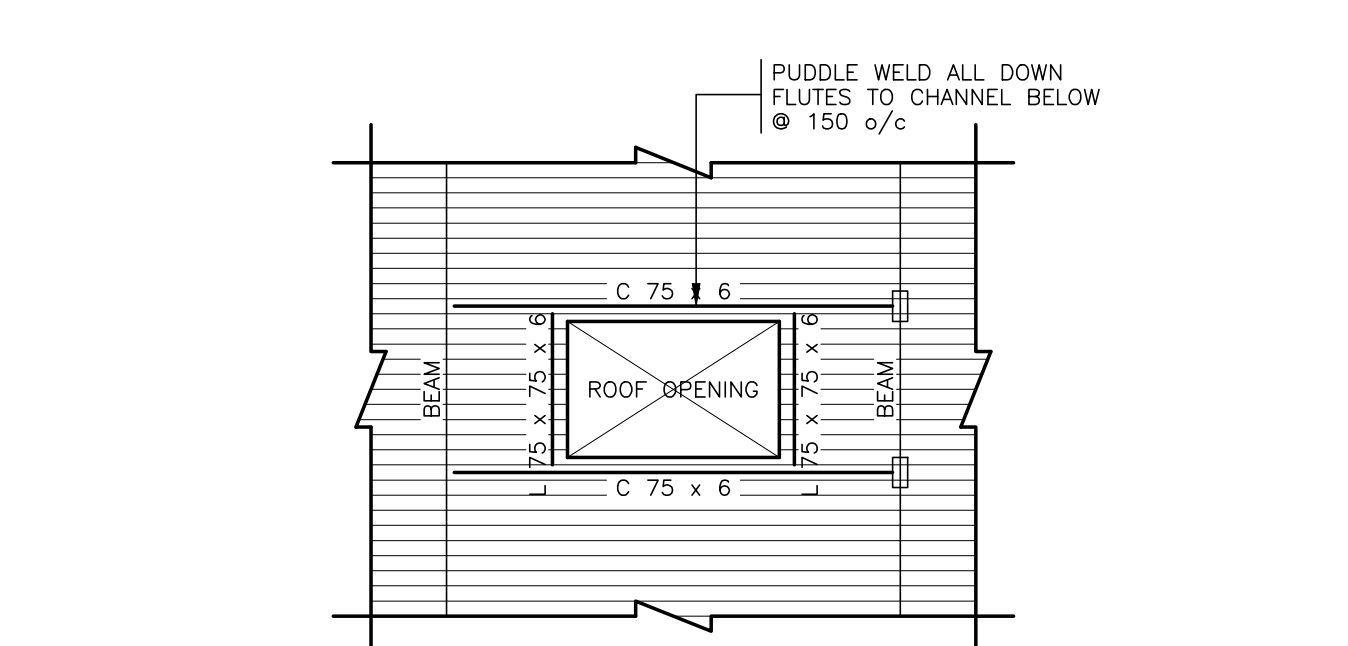

TYPICAL DETAIL- ADDITIONAL FRAMING AT ROOF OPENINGS

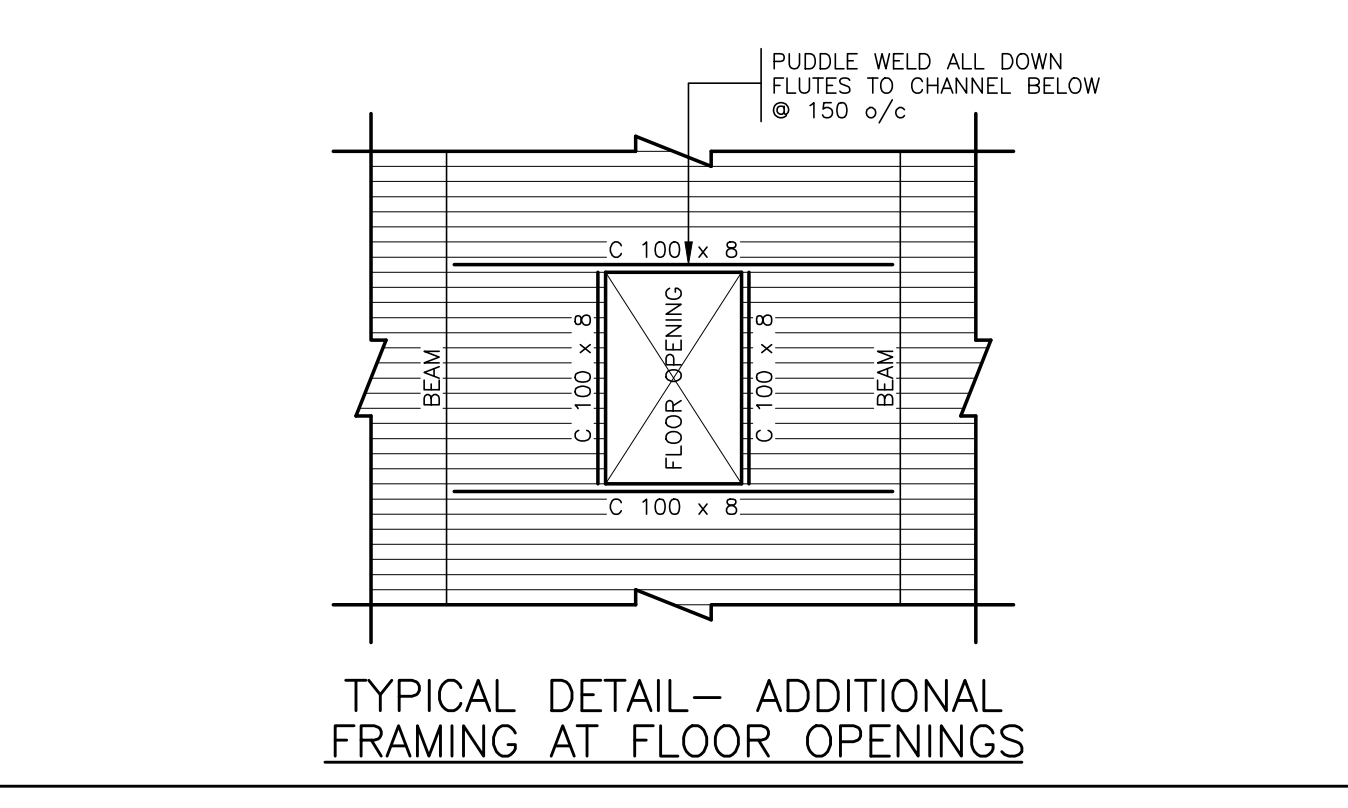

TYPICAL DETAIL- ADDITIONAL FRAMING AT FLOOR OPENINGS



6			
5			
4			
3	ISSUED FOR CONSTRUCTION	2017/09/29	RW
2	ISSUED FOR BUILDING PERMIT	2017/07/25	RW
1	ISSUED FOR INFORMATION	2017/06/23	RW
NUMBER / MILESTONE / FAT SAILLANT	DATE / (Y/M/D) / (A/M/J)	INITIALS / INTIALES	
DESIGNED BY / CONÇU PAR	JC	CHECKED BY / VÉRIFIÉ PAR	JC
DRAWN BY / DÉSSINÉ PAR	RW	SCALE / ÉCHELLE	NOT TO SCALE

DETAIL NUMBER	DRAWING TITLE
1.1	TYPICAL DETAILS
SHEET NUMBER	

THIS DRAWING IS THE PROPERTY OF THE CITY OF OTTAWA AND ALL COPYRIGHT IS RESERVED. DIMENSIONS ON DRAWING ARE FOR ESTIMATING PURPOSES ONLY. IT IS THE RESPONSIBILITY OF EACH CONTRACTOR AND SUB-CONTRACTOR OR CONSULTANT TO CHECK AND VERIFY ALL DIMENSIONS AND CONDITIONS ON SITE. NOTIFY OWNER OF ANY ERRORS OR OMISSIONS PRIOR TO COMMENCING THE WORK. DO NOT SCALE THE DRAWINGS.

CE DESSIN CONSTITUE LA PROPRIÉTÉ DE LA VILLE D'OTTAWA ET TOUT DROIT D'AUTEUR EST RÉSERVÉ. LES DIMENSIONS UTILISÉES SE SONT À DES FINS DESTINATION SEULEMENT. IL INCOMBE À CHAQUE ENTREPRENEUR, SOUS-CONTRACTANT OU CONSULTANT DE VÉRIFIER TOUTES LES DIMENSIONS ET LES CONDITIONS SUR LE CHANTIER. VEUILLEZ INFORMER LE PROPRIÉTAIRE DE TOUTE ERREUR OU OMISSION AVANT D'ENTAMER LES TRAVAUX. NE DRESSÉZ PAS LES PLANS À L'ÉCHELLE.

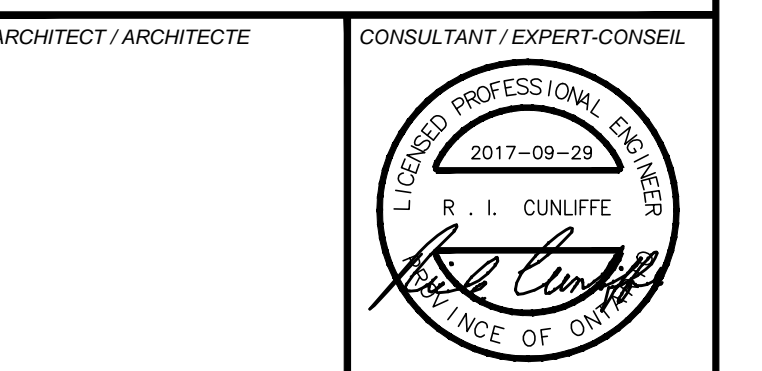

ARCHITECT / ARCHITECTE	CONSULTANT / EXPERT-CONSEIL
CONSULTANT / EXPERT-CONSEIL	CONSULTANT / EXPERT-CONSEIL

PROJECT / LOCATION / PROJET / ENDROIT
DOVERCOURT
PHASE 2
ADDITION & RENOVATION
411 DOVERCOURT
OTTAWA, ONTARIO
DRAWING / DESSIN
TYPICAL DETAILS
FACILITY NO. / NO. DE INSTALLATIONS
SHEET NO. / FEUILLE No.
S02



6			
5			
4			
3	ISSUED FOR CONSTRUCTION	2017/09/29	RW
2	ISSUED FOR BUILDING PERMIT	2017/07/25	RW
1	ISSUED FOR INFORMATION	2017/06/23	RW
NUMBER / NUMÉRO	DATE / DATE	(Y/M/D) / (A/M/J)	INITIALS / INITIALES
DESIGNED BY / CONÇU PAR	JC	CHECKED BY / VÉRIFIÉ PAR	JC
DRAWN BY / DÉSSINÉ PAR	RW	SCALE / ÉCHELLE	1:50

DETAIL NUMBER	7
DRAWING TITLE	FOUNDATION PLAN
SCALE	1:50
SHEET NUMBER	1

THIS DRAWING IS THE PROPERTY OF THE CITY OF OTTAWA AND ALL COPYRIGHT IS RESERVED. DIMENSIONS ON DRAWING ARE FOR ESTIMATING PURPOSES ONLY. IT IS THE RESPONSIBILITY OF EACH CONTRACTOR AND SUB-CONTRACTOR OR CONSULTANT TO CHECK AND VERIFY ALL DIMENSIONS AND CONDITIONS ON SITE. NOTIFY OWNER OF ANY ERRORS OR OMISSIONS PRIOR TO COMMENCING THE WORK. DO NOT SCALE THE DRAWINGS.

CE DESSIN CONSTITUE LA PROPRIÉTÉ DE LA VILLE D'OTTAWA ET TOUT DROIT D'AUTEUR EST RÉSERVÉ. LES DIMENSIONS UTILISÉES SE SONT À DES FINS DESTINATION SEULEMENT. IL INCOMBE À CHAQUE ENTREPRENEUR, SOUS-CONTRACTANT OU CONSULTANT DE VÉRIFIER TOUTES LES DIMENSIONS ET LES CONDITIONS SUR LE CHANTIER. VEUILLEZ INFORMER LE PROPRIÉTAIRE DE TOUTE ERREUR OU OMISSION AVANT D'ENTAMER LES TRAVAUX. NE DRESSEZ PAS LES PLANS À L'ÉCHELLE.

ARCHITECT / ARCHITECTE	CONSULTANT / EXPERT-CONSEIL

CONSULTANT / EXPERT-CONSEIL	CONSULTANT / EXPERT-CONSEIL
-----------------------------	-----------------------------

PROJECT / LOCATION / PROJET / ENDROIT
DOVERCOURT
PHASE 2
ADDITION & RENOVATION
 411 DOVERCOURT
 OTTAWA, ONTARIO

DRAWING / DESSIN
FLOOR PLANS
FOUNDATION PLAN

FACILITY NO. / NO. DE INSTALLATIONS	SHEET NO. / FEUILLE No.
PROJECT NO. / PROJET NO.	S100
	1713

CAISSON SCHEDULE		
MARK	SIZE	REINF'G
CA1	600 DIAMETER	8-20M VERTICAL 1-10M TIE @ 300 o/c DRILL 200 DP HOLES INTO (ex) FOOTING TO ACCEPT 4-20M x 1000 Lg DWLS. SECURE IN HOLE USING BUILT UP HYDRO ADHESIVE. LAP DWLS WITH ALTERNATE VERTICAL REINFORCING. PROVIDE 90° STANDARD BEND AT TOP OF 8-20M VERTICAL & LOCATED BEND 50 mm BELOW TOP OF GRADE BEAM

STEEL COLUMN SCHEDULE	
MARK	SIZE
SC1	HSS 127 x 127 x 6.4

NOTES:
 1. ALL HSS SECTIONS TO BE ASTM A500 (GRADE C) OR G40.21M350W (CLASS C).
 2. SEE ALSO GENERAL NOTES ON S01.

BASEPLATE SCHEDULE			
MARK	SIZE	ANCHORS	WASHERS
BP1	350 x 350 x 20 THK PLATE	4-M20 # HEADED ANCHOR BOLTS 300 mm EMBEDMENT	50 # x 5 THK

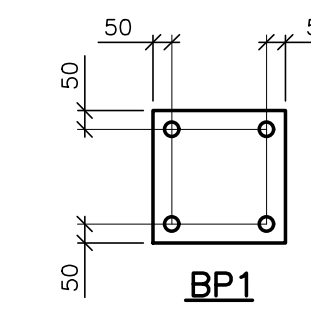

- NOTE:
- PROVIDE 25 mm NON SHRINK GROUT OR DRYPACK BELOW BASEPLATES EXTENDING 25 mm BEYOND PERIMETER OF PLATE AND FOR FULL AREA BELOW PLATE (NOT APPLICABLE TO CAST-IN PLATES)
 - PROVIDE 50 mm ANCHOR BOLT PROJECTION ABOVE PLATE.
 - ALL ANCHOR BOLTS TO BE ASTM A307 u/n
 - ALL BASE PLATES TO BE GRADE G40.21300W
 - ALL COLUMNS TO BE CENTRED ON BASEPLATES U/N
 - USE STEEL TEMPLATES AND PRECISE SURVEYING TECHNIQUES TO ACCURATELY LOCATE BASE PLATE & ANCHOR BOLTS.

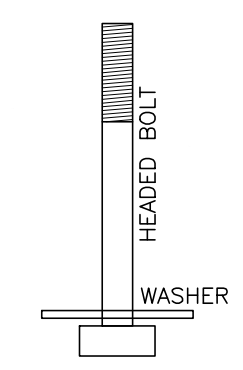

GRADE BEAM SCHEDULE		
MARK	SIZE	REINFORCING
GB	1000 x 1250 DP	4-25M T & B CONT 2-25M EF EQUALLY SPACED BTW T & B 1-15M CLOSED TIE @ 300 o/c
GB1	1500 x 1250 DP	5-25M T & B CONT 2-25M EF EQUALLY SPACED BTW T & B 1-15M CLOSED TIE @ 300 o/c

NOTES:
 1. ENDS OF HORIZONTAL CONT BARS ARE TO TERMINATE WITH 90° x 300 Lg BENDS AT THE FAR FACE OF THE WALL OR END OF BEAM.
 2. WHERE DEPTH OF GRADE BEAM VARIES, USE 15M "U" BARS T & B @ 300 o/c TO CREATE A CLOSED TIE
 3. REINFORCING LAPS
 TOP REINF'G @ MID-SPAN BETWEEN PIERS
 LAP BOTTOM REINF'G @ PIERS
 LAP REMAINING REINF'G @ PIERS

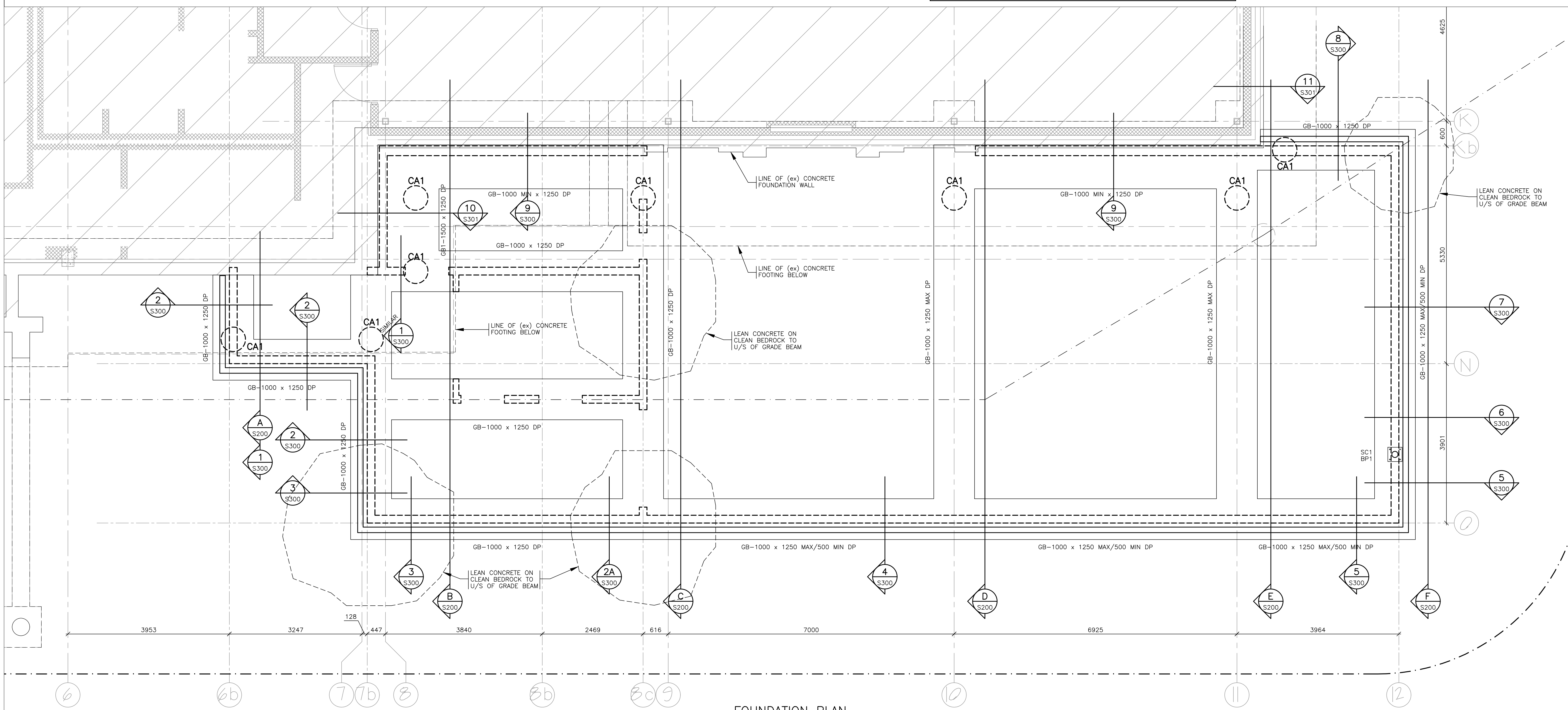

FOUNDATION PLAN
 SCALE 1 : 50

CONCRETE COMPRESSIVE STRENGTH
 MASS CONCRETE FILL - 15 MPa TYPE N
 INTERIOR SLAB ON GRADE - 25 MPa TYPE N
 EXTERIOR SLAB ON GRADE - 32 MPa CLASS C2
 PERIMETER FOUNDATION WALLS - 25 MPa CLASS F2
 GRADE BEAMS - 25 MPa TYPE N
 CAISSONS - 25 MPa TYPE N

MASONRY VENEER LOOSE LINTEL SCHEDULE		
SPAN	SIZE	BEARING EE
0 - 1200 mm	L 89 x 89 x 8	100 mm
1201 TO 1800	L 102 x 89 x 8 LLV	100 mm
1801 - 2400	L 127 x 89 x 8 LLV	100 mm
2401 - 3000	L 152 x 102 x 8 LLV	150 mm
3001 - 3400	L 152 x 102 x 9.5 LLV	175 mm

NOTE:
1. ALL "EXTERIOR" ANGLES ARE TO BE HOT DIP GALVANIZED

STEEL COLUMN SCHEDULE	
MARK	SIZE
SC1	HSS 152 O.D. x 6.4

NOTES:
1. ALL HSS SECTIONS TO BE ASTM A500 (GRADE C) OR G40.21M350W (CLASS C).
2. SEE ALSO GENERAL NOTES ON S01.

MASONRY PIER SCHEDULE		
MARK	SIZE	REINFORCEMENT
MP1	790 Lg x THICKNESS OF BLOCK	4-20M VERT. + 4-20M DOWEL c/w 1 - 4.88 Ø GALVANIZED WIRE TIE @ 200 o/c
MP2	990 x 190	5-20M VERT. + 5-20M DOWEL c/w 1 - 4.88 Ø GALVANIZED WIRE TIE @ 200 o/c
MP3	190 x 800+ 190 x 200 (SEE PLAN)	5-20M VERT. + 5-20M DOWEL c/w HEAVY DUTY LADDER TIE @ 200 o/c (SEE DETAIL BELOW)

NOTES:
1. ALL MASONRY PIERS TO BE GROUTED SOLID.
2. ALL MASONRY PIERS TO BE FULL HEIGHT OF WALL

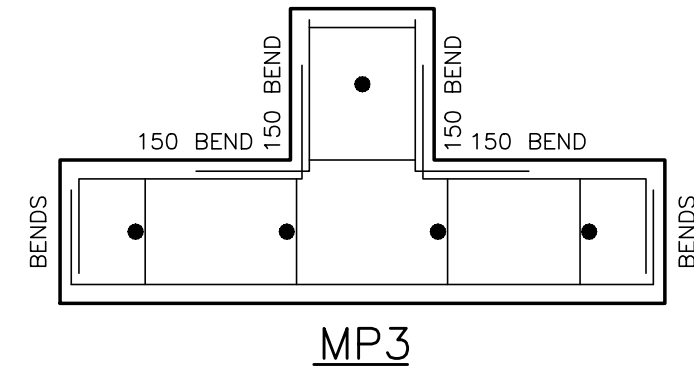

CONCRETE BLOCK WALL MASONRY LINTEL SCHEDULE UNLESS NOTED WITH ML#	
SPAN	SIZE & REINF'G
140 OR 190 WD REINF'D CONC BLOCK	
0 - 1000 mm	200 DP 1-15M BOT CONT
1001 - 1900	400 DP 1-20M BOT CONT
1901 - 2500	600 DP 1-20M TOP & BOT CONT
2501 - 3200	800 DP 1-20M TOP & BOT CONT

NOTE:
1. ALL MASONRY LINTELS ARE TO BE GROUTED SOLID
2. GROUT WALL ENDS SOLID BELOW LINTEL FOR WIDTH OF 200 mm LINTEL BEARING
3. SEE DRAWING S00 FOR MASONRY REINFORCEMENT. PROVIDE 1-20M VERT IN EACH GROUTED CORE AT WALL ENDS EACH SIDE OF LINTEL OPENING UNLESS NOTED OTHERWISE ON PLANS.
4. USE LOW WEB BLOCKS FOR LINTEL COURSES CONTAINING HORIZONTAL REBAR

LOAD BEARING MASONRY LINTEL SCHEDULE			
MARK	SIZE	REINF'G	BEARING
ML1	190 x 590 DP	1-20M BOTTOM	200
ML2	190 x 390 DP	1-20M BOTTOM	200
ML3	190 x 990 DP	1-20M BOTTOM 1-15M TOP & MID	300

NOTE:
1. ALL LINTELS ARE TO BE GROUTED SOLID
2. GROUT WALL ENDS SOLID BELOW LINTEL FOR WIDTH OF BEARING INDICATED ABOVE.
3. SEE DRAWING S01 & SCHEDULE FOR MASONRY REINFORCEMENT. PROVIDE 1-20M VERT IN EACH GROUTED CORE AT WALL ENDS EACH SIDE OF LINTEL OPENING UNLESS NOTED OTHERWISE ON PLANS.
4. USE SPECIAL LINTEL BLOCKS FOR LOWEST LINTEL COURSE AND USE LOW WEB BLOCKS FOR ALL OTHER LINTEL COURSES.
5. DO NOT INTERRUPT TYPICAL WALL REINFORCEMENT AT LINTELS.

MASONRY WALL SCHEDULE			
MARK	THICKNESS/GROUTING	REINFORCING	
		VERT.	HORIZ.
MW1	190mm GROUTED @ 600	15M @ 600 o/c	HL2 @ 200 o/c
MW2	190mm GROUTED @ 400	15M @ 400 o/c	HL2 @ 200 o/c
MW3	190mm GROUTED SOLID	15M @ 400 o/c	HL2 @ 200 o/c

NOTE:
1. PROVIDE ADDITIONAL REINFORCING AS FOLLOWS: 1-20M VERT. @ ES OPENINGS, CORNERS & INTERSECTIONS FULLY GROUTED
2. ALL BLOCK WALL SECTIONS EQUAL TO OR LESS THAN 800 mm IN LENGTH TO BE FULLY GROUTED AND REINFORCED WITH 15M VERTICAL @ 200 o/c & HL2 @ 200 o/c (UNLESS NOTED OTHERWISE).
3. SEE PLANS FOR LOCATIONS & EXTENT OF MW #.
4. SEE GENERAL NOTES ON DWG S01 FOR TYPICAL MASONRY WALL REINFORCING UNLESS NOTED OTHERWISE IN SCHEDULE OR ON PLAN.
5. SEE PLANS FOR LOCATIONS OF CONTROL JOINTS (NOTED CJ ON PLAN)

LEGEND
H-HEAVY 5 mm LONGITUDINAL WIRES
9 GAUGE CROSS WIRES
L-LADDER TYPE REINFORCEMENT
2-2 LONGITUDINAL WIRES

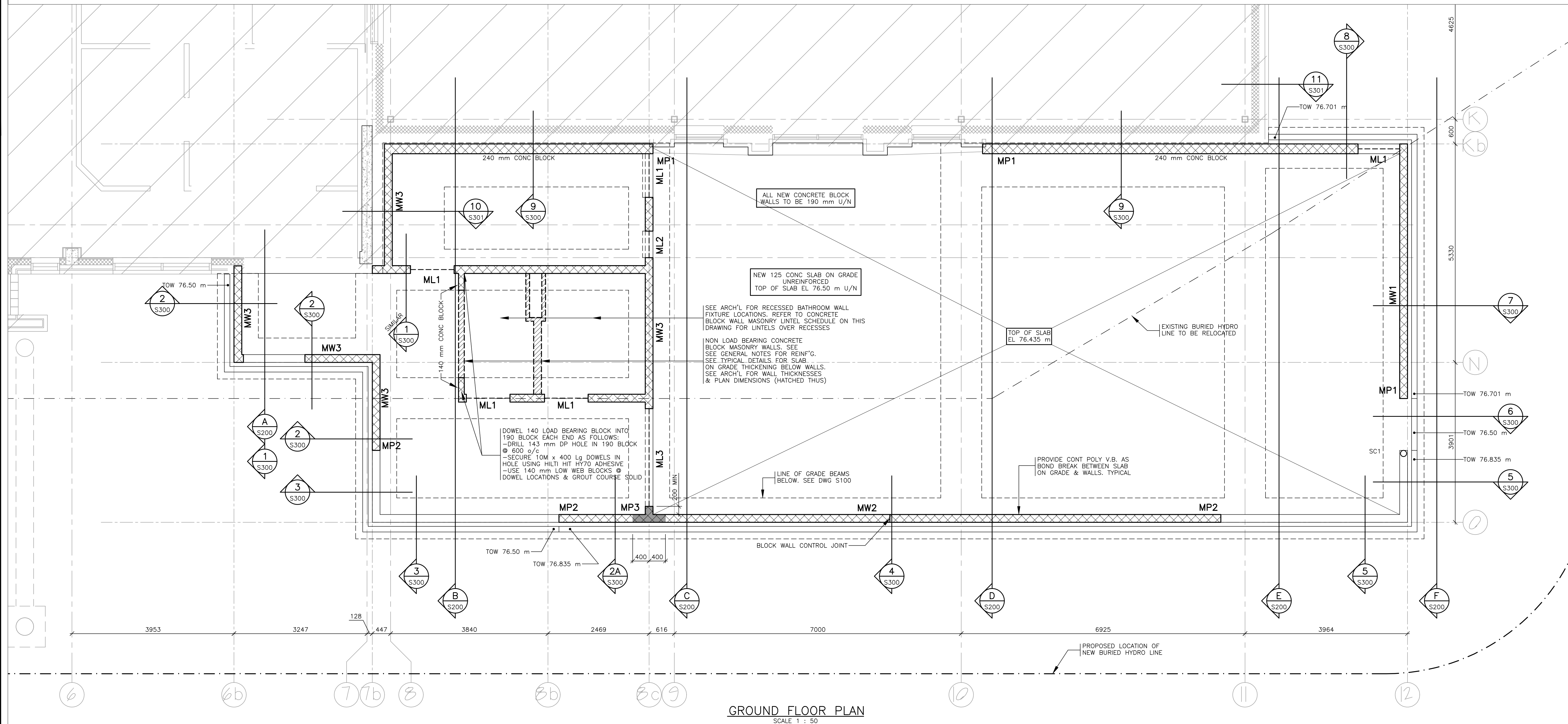

GROUND FLOOR PLAN
SCALE 1 : 50

CONCRETE COMPRESSIVE STRENGTH
 INTERIOR SLAB ON GRADE - 25 MPa TYPE N
 EXTERIOR SLAB ON GRADE - 32 MPa CLASS C2
 PERIMETER FOUNDATION WALLS - 25 MPa CLASS F2
 GRADE BEAMS - 25 MPa TYPE N

Ottawa
 DEPARTMENT OF CORPORATE SERVICES / SERVICES GÉNÉRAUX
 REAL PROPERTY ASSET MANAGEMENT BRANCH
 DIRECTION DE LA GESTION DES ACTIFS ET DES BIENS IMMOBILIERS
 DESIGN AND CONSTRUCTION DIVISION /
 DIVISION DE LA CONCEPTION ET DE LA CONSTRUCTION

GREG GEDES CHIEF CORPORATE SERVICES OFFICER /
 CHEF DES SERVICES GÉNÉRAUX
 S.A. FINAMORE, O.A.A. DIRECTOR / DIRECTEUR, O.A.O.
 ROBERT VAILLANCOURT, O.A.A. MANAGER / GESTIONNAIRE, O.A.O.

FOR / POUR

Dovercourt
 RECREATION CENTRE

CUNLIFFE
 CUNLIFFE & ASSOCIATES
 CONSULTING STRUCTURAL ENGINEERS
 102-1737 WOODWARD DR. OTTAWA ON K2C 0P9
 TEL: (613) 729-7242 FAX: (613) 729-1461
 Email: cunliffe@cunliffe.ca

NUMBER	REVISION / MILESTONE / FMT SAILLANT	DATE	(Y/M/D)	INITIALS
6				
5				
4				
3	ISSUED FOR CONSTRUCTION	2017/09/29	RW	
2	ISSUED FOR BUILDING PERMIT	2017/07/25	RW	
1	ISSUED FOR INFORMATION	2017/06/23	RW	

DESIGNED BY / CONÇU PAR JC	CHECKED BY / VÉRIFIÉ PAR JC
DRAWN BY / DÉSSINÉ PAR RW	SCALE / ÉCHELLE 1:50

DETAIL NUMBER 11	DRAWING TITLE GROUND FLOOR PLAN
SHEET NUMBER 11	SCALE 1:50

THIS DRAWING IS THE PROPERTY OF THE CITY OF OTTAWA AND ALL COPYRIGHT IS RESERVED. NO DIMENSIONS ON DRAWING ARE FOR ESTIMATING PURPOSES ONLY. IT IS THE RESPONSIBILITY OF EACH CONTRACTOR AND SUB-CONTRACTOR OR CONSULTANT TO CHECK AND VERIFY ALL DIMENSIONS AND CONDITIONS ON SITE. NOTIFY OWNER OF ANY ERRORS OR OMISSIONS PRIOR TO COMMENCING THE WORK. DO NOT SCALE THE DRAWINGS.

CE Dessin constitue la propriété de la Ville d'Ottawa et tout droit de copyright est réservé. Les dimensions utilisées ne sont à des fins d'estimation seulement. Il incombe à chaque entrepreneur, sous-contractant ou consultant de vérifier toutes les dimensions et les conditions sur le chantier. Veuillez informer le propriétaire de toute erreur ou omission avant d'entamer les travaux. Ne dressez pas les plans à l'échelle.

ARCHITECT / ARCHITECTE
 CONSULTANT / EXPERT-CONSEIL
 R. I. CUNLIFFE
 LICENSED PROFESSIONAL ENGINEER
 2017-09-29
 R. I. CUNLIFFE
 CIVIL ENGINEER OF ONTARIO

PROJECT / LOCATION / PROJET / ENDROIT
DOVERCOURT
 PHASE 2
 ADDITION & RENOVATION
 411 DOVERCOURT
 OTTAWA, ONTARIO

DRAWING / DESSIN
 FLOOR PLANS
 GROUND FLOOR PLAN

FACILITY NO. / NO. DE INSTALLATIONS	SHEET NO. / FEUILLE No.
PROJECT NO. / PROJET NO.	S101
	1713

BEAM BEARING PLATE SCHEDULE		
MARK	SIZE	ANCHORS
BBP1	150 x 300 x 16 THK PLATE	2-15M x 400 Lg WELDABLE REBAR
BBP2	130 x 400 x 16 THK PLATE	2-15M x 400 Lg WELDABLE REBAR

NOTES:

- BEAMS SUPPORTED ON BEAM BEARING BASE PLATES TO EXTEND ONTO PLATE A MINIMUM OF 80% OF LENGTH OF PLATE, IN DIRECTION OF BEAM UNLESS NOTED OTHERWISE ON PLAN.
- ANCHORS ARE TO BE CENTERED ON PLATE & SPACED AT 200 o/c TO ALIGN WITH CORE VOIDS IN BLOCK UNLESS OTHERWISE NOTED
- ENSURE BEAM POCKETS IN MASONRY WALLS ARE BUILT-IN WITH MASONRY OR GROUTED SOLID.
- ENSURE WALLS ARE GROUTED AT LEAST 3 COURSES BELOW BEAM BEARING PLATES.

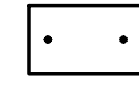

BBP1 & BBP2

MASONRY PIER SCHEDULE		
MARK	SIZE	REINFORCEMENT
MP1	790 Lg x THICKNESS OF BLOCK	4-20M VERT. + 4-20M DOWEL c/w 1 - 4.88 Ø GALVANIZED WIRE TIE @ 200 o/c
MP2	990 x 190	5-20M VERT. + 5-20M DOWEL c/w 1 - 4.88 Ø GALVANIZED WIRE TIE @ 200 o/c
MP3	190 x 800+ 190 x 200 (SEE PLAN)	5-20M VERT. + 5-20M DOWEL c/w HEAVY DUTY LADDER TIE @ 200 o/c (SEE DETAIL BELOW)

NOTES:

- ALL MASONRY PIERS TO BE GROUTED SOLID.
- ALL MASONRY PIERS TO BE FULL HEIGHT OF WALL

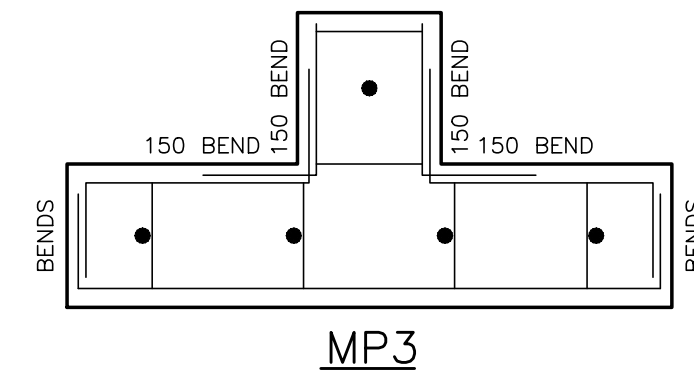

CONCRETE BLOCK WALL MASONRY LINTEL SCHEDULE UNLESS NOTED WITH ML#	
SPAN	SIZE & REINF'G
140 OR 190 WD REINF'D CONC BLOCK	
0 - 1000 mm	200 DP 1-15M BOT CONT
1001 - 1900	400 DP 1-20M BOT CONT
1901 - 2500	600 DP 1-20M TOP & BOT CONT
2501 - 3200	800 DP 1-20M TOP & BOT CONT

NOTE:

- ALL MASONRY LINTELS ARE TO BE GROUTED SOLID
- GROUT WALL ENDS SOLID BELOW LINTEL FOR WIDTH OF BEARING INDICATED ABOVE.
- SEE DRAWING S01 & SCHEDULE FOR MASONRY REINFORCEMENT. PROVIDE 1-20M VERT IN EACH GROUTED CORE AT WALL ENDS EACH SIDE OF LINTEL OPENING UNLESS NOTED OTHERWISE ON PLANS.
- USE SPECIAL LINTEL BLOCKS FOR LOWEST LINTEL COURSE AND USE LOW WEB BLOCKS FOR ALL OTHER LINTEL COURSES.
- DO NOT INTERRUPT TYPICAL WALL REINFORCEMENT AT LINTELS.

LOAD BEARING MASONRY LINTEL SCHEDULE			
MARK	SIZE	REINF'G	BEARING
ML1	190 x 590 DP	1-20M BOTTOM	200

NOTE:

- ALL LINTELS ARE TO BE GROUTED SOLID
- GROUT WALL ENDS SOLID BELOW LINTEL FOR WIDTH OF BEARING INDICATED ABOVE.
- SEE DRAWING S01 & SCHEDULE FOR MASONRY REINFORCEMENT. PROVIDE 1-20M VERT IN EACH GROUTED CORE AT WALL ENDS EACH SIDE OF LINTEL OPENING UNLESS NOTED OTHERWISE ON PLANS.
- USE SPECIAL LINTEL BLOCKS FOR LOWEST LINTEL COURSE AND USE LOW WEB BLOCKS FOR ALL OTHER LINTEL COURSES.
- DO NOT INTERRUPT TYPICAL WALL REINFORCEMENT AT LINTELS.

STEEL COLUMN SCHEDULE	
MARK	SIZE
SC1	HSS 152 O.D. x 6.4

NOTES:

- ALL HSS SECTIONS TO BE ASTM A500 (GRADE C) OR G40.21M350W (CLASS C).
- SEE ALSO GENERAL NOTES ON S01.

MASONRY WALL SCHEDULE			
MARK	THICKNESS/GROUTING	REINFORCING	
		VERT.	HORIZ.
MW1	190mm GROUTED @ 600	15M @ 600 o/c	HL2 @ 200 o/c
MW2	190mm GROUTED @ 400	15M @ 400 o/c	HL2 @ 200 o/c
MW3	190mm GROUTED SOLID	15M @ 400 o/c	HL2 @ 200 o/c

NOTE:

- PROVIDE ADDITIONAL REINFORCING AS FOLLOWS: 1-20M VERT. @ ES OPENINGS, CORNERS & INTERSECTIONS FULLY GROUTED
- ALL BLOCK WALL SECTIONS EQUAL TO OR LESS THAN 800 mm IN LENGTH TO BE FULLY GROUTED AND REINFORCED WITH 15M VERTICAL @ 200 o/c & HL2 @ 200 o/c (UNLESS NOTED OTHERWISE).
- SEE PLANS FOR LOCATIONS & EXTENT OF MW #.
- SEE GENERAL NOTES ON DWG S01 FOR TYPICAL MASONRY WALL REINFORCING UNLESS NOTED OTHERWISE IN SCHEDULE OR ON PLAN.
- SEE PLANS FOR LOCATIONS OF CONTROL JOINTS (NOTED CJ ON PLAN)

LEGEND

H-HEAVY 5 mm LONGITUDINAL WIRES
9 GAUGE CROSS WIRES
L-LADDER TYPE REINFORCEMENT
2-2 LONGITUDINAL WIRES



DEPARTMENT OF CORPORATE SERVICES / SERVICES GÉNÉRAUX
REAL PROPERTY ASSET MANAGEMENT BRANCH /
DIRECTION DE LA GESTION DES ACTIFS ET DES BIENS IMMOBILIERS
DIVISION DE LA CONCEPTION ET DE LA CONSTRUCTION

GREG GEDES CHIEF CORPORATE SERVICES OFFICER /
CHEF DES SERVICES GÉNÉRAUX
S.A. FINNMORE, O.A.A. DIRECTOR / DIRECTEUR, O.A.O.
ROBERT VAILLANCOURT, O.A.A. MANAGER / GESTIONNAIRE, O.A.O.

FOR / POUR



CUNLIFFE & ASSOCIATES
CONSULTING STRUCTURAL ENGINEERS
102-1737 WOODWARD DR. OTTAWA ON K2C 0P9
TEL: (613) 729-7242 FAX: (613) 729-1461
Email: cunliffe@cunliffe.ca

NUMBER	REVISION / MILESTONE / FMT SAILLANT	DATE (Y/M/D)	INITIALES
6			
5			
4			
3	ISSUED FOR CONSTRUCTION	2017/09/29	RW
2	ISSUED FOR BUILDING PERMIT	2017/07/25	RW
1	ISSUED FOR INFORMATION	2017/06/23	RW

DESIGNED BY / CONÇU PAR JC	CHECKED BY / VÉRIFIÉ PAR JC
DRAWN BY / DÉSSINÉ PAR RW	SCALE / ÉCHELLE 1:50

DETAIL NUMBER	DRAWING TITLE	SHEET NUMBER
1	1:1	

THIS DRAWING IS THE PROPERTY OF THE CITY OF OTTAWA AND ALL COPYRIGHT IS RESERVED. LES DIMENSIONS ON DRAWING ARE FOR ESTIMATING PURPOSES ONLY. IT IS THE RESPONSIBILITY OF EACH CONTRACTOR AND SUB-CONTRACTOR OR CONSULTANT TO CHECK AND VERIFY ALL DIMENSIONS AND CONDITIONS ON SITE. NOTIFY OWNER OF ANY ERRORS OR OMISSIONS PRIOR TO COMMENCING THE WORK. DO NOT SCALE THE DRAWINGS.

CE DESSIN CONSTITUE LA PROPRIÉTÉ DE LA VILLE D'OTTAWA ET TOUT DROIT D'AUTEUR EST RÉSERVÉ. LES DIMENSIONS UTILISÉES SE SONT À DES FINS DESTINATION SEULEMENT. IL INCOMBE À CHAQUE ENTREPRENEUR, SOUS-CONTRACTANT OU CONSULTANT DE VÉRIFIER TOUTES LES DIMENSIONS ET LES CONDITIONS SUR LE CHANTIER. VEUILLEZ INFORMER LE PROPRIÉTAIRE DE TOUTE ERREUR OU OMISSION AVANT D'ENTAMER LES TRAVAUX. NE DRESSEZ PAS LES PLANS À L'ÉCHELLE.

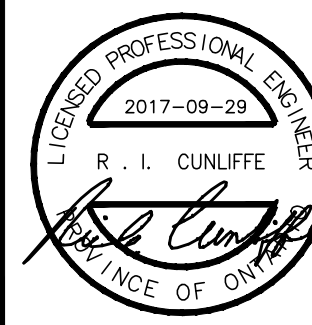
ARCHITECT / ARCHITECTE	CONSULTANT / EXPERT-CONSEIL
	
CONSULTANT / EXPERT-CONSEIL	CONSULTANT / EXPERT-CONSEIL

PROJECT / LOCATION / PROJET / ENDROIT

DOVERCOURT
PHASE 2
ADDITION & RENOVATION

411 DOVERCOURT
OTTAWA, ONTARIO

DRAWING / DESSIN
FLOOR PLANS
STORAGE ROOM PLAN

DESIGN LOADS:	STORAGE ROOM
64 CONC TOP(102 MAX.)	1.80 kPa
STEEL DECK	0.10
STRUCTURE	0.20
CEILING & FLOORING	0.20
MECH/ELECT. & MISC	0.20
DEAD LOAD	2.50 kPa
LIVE LOAD	4.80 kPa
TOTAL LOAD	7.30 kPa

FACILITY NO. / NO. DE INSTALLATIONS

SHEET NO. / FEUILLE No.

S102

PROJECT NO. / PROJET NO.

1713

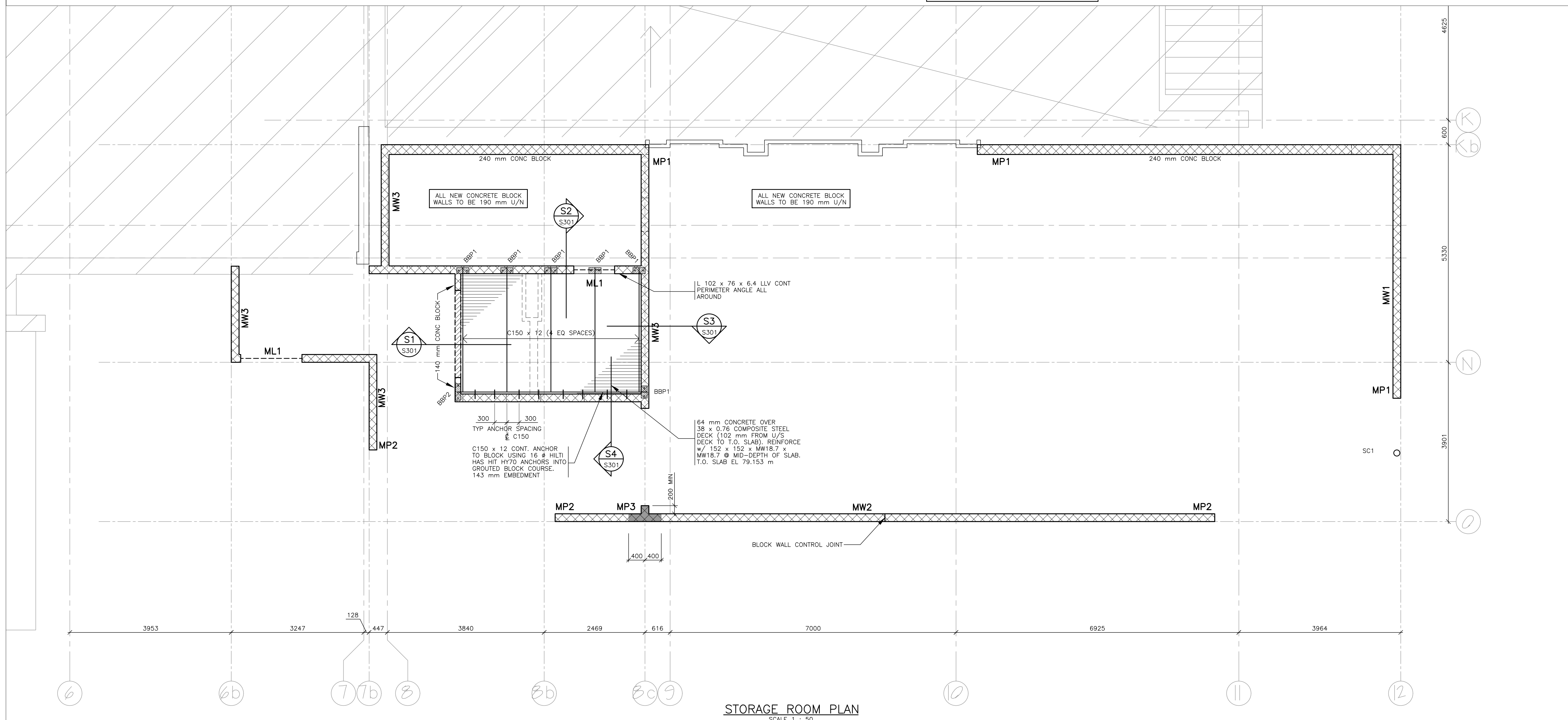

STORAGE ROOM PLAN
SCALE 1 : 50

CONCRETE COMPRESSIVE STRENGTH
SLAB ON DECK - 25 MPa TYPE N

ROOF TOP MECH'L UNIT

RTU
2261 x 1499 x 1645 HIGH
(INCLUDES 356 mm CURB)
WT = 772 Kg (INCLUDES CURB)

- NOTES:
- REFER TO DWG S02 FOR ADDITIONAL FRAMING BELOW MECH'L UNITS & AT ROOF OPENINGS
 - REFER TO DWG S02 FOR CONCRETE SLAB & CURB DETAILS BELOW MECH'L UNITS
 - COORDINATE MECH'L UNIT OPENINGS WITH MECH'L ENGINEER
 - NOTIFY CUNLIFFE & ASSOCIATES IF ANY OF THE MECH'L UNIT INFORMATION NOTED ON THIS DRAWING DIFFERS FROM THE ACTUAL UNITS SUPPLIED FOR INSTALLATION.
 - 64 CONC SLAB ON 38 x 1.21 COMPOSITE STEEL DECK, REINFORCE SLAB w/ 1 LAYER 152 x 152 x MW18.7 x MW18.7 @ MIDDEPTH OF SLAB, TOP OF SLAB TO FOLLOW ROOF SLOPE. SEE DETAIL ON DRAWING S02 FOR SLAB & CURBS.

STEEL COLUMN SCHEDULE

MARK	SIZE
SC1	HSS 152 O.D. x 6.4

NOTES:

- ALL HSS SECTIONS TO BE ASTM A500 (GRADE C) OR G40.21M350W (CLASS C).
- SEE ALSO GENERAL NOTES ON S01.

BEAM BEARING PLATE SCHEDULE

MARK	SIZE	ANCHORS
BBP2	130 x 400 x 16 THK PLATE	2-15M x 400 Lg WELDABLE REBAR
BBP3	180 x 350 x 16 THK PLATE	2-15M x 400 Lg WELDABLE REBAR
BBP4	180 x 800 x 25 THK PLATE	4-20M x 800 Lg WELDABLE REBAR
BBP5	180 x 400 x 25 THK PLATE	2-15M x 400 Lg WELDABLE REBAR

NOTES:

- BEAMS SUPPORTED ON BEAM BEARING BASE PLATES TO EXTEND ONTO PLATE A MINIMUM OF 80% OF LENGTH OF PLATE, IN DIRECTION OF BEAM UNLESS NOTED OTHERWISE ON PLAN.
- ANCHORS ARE TO BE CENTERED ON PLATE & SPACED AT 200 o/c TO ALIGN WITH CORE VOIDS IN BLOCK UNLESS OTHERWISE NOTED
- ENSURE BEAM POCKETS IN MASONRY WALLS ARE BUILT-IN WITH MASONRY OR GROUTED SOLID.
- ENSURE WALLS ARE GROUTED AT LEAST 3 COURSES BELOW BEAM BEARING PLATES.

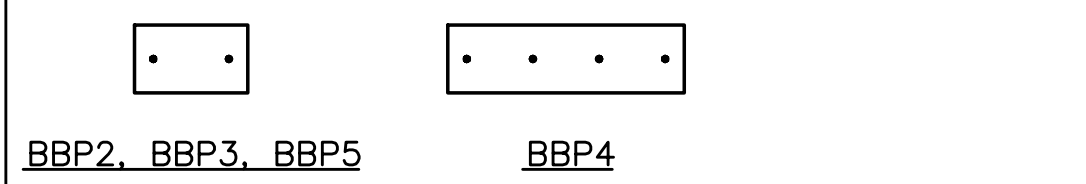

MASONRY PIER SCHEDULE

MARK	SIZE	REINFORCEMENT
MP1	790 Lg x THICKNESS OF BLOCK	4-20M VERT. + 4-20M DOWEL c/w 1 - 4.88 @ GALVANIZED WIRE TIE @ 200 o/c
MP2	990 x 190	5-20M VERT. + 5-20M DOWEL c/w 1 - 4.88 @ GALVANIZED WIRE TIE @ 200 o/c
MP3	190 x 800 + 190 x 200 (SEE PLAN)	5-20M VERT. + 5-20M DOWEL c/w HEAVY DUTY LADDER TIE @ 200 o/c (SEE DETAIL BELOW)

NOTES:

- ALL MASONRY PIERS TO BE GROUTED SOLID.
- ALL MASONRY PIERS TO BE FULL HEIGHT OF WALL.

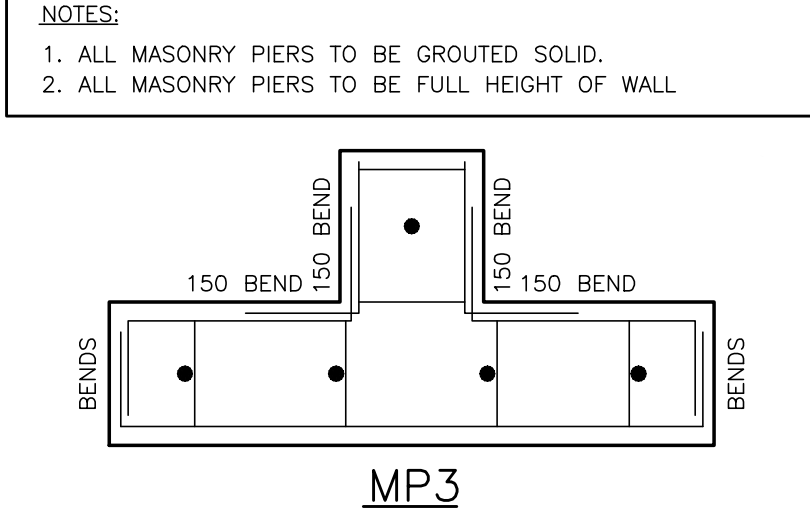

CONCRETE BLOCK WALL MASONRY LINTEL SCHEDULE UNLESS NOTED WITH ML#

SPAN	SIZE & REINF'G
0 - 1000 mm	200 DP 1-15M BOT CONT
1001 - 1900	400 DP 1-20M BOT CONT
1901 - 2500	600 DP 1-20M TOP & BOT CONT
2501 - 3200	800 DP 1-20M TOP & BOT CONT

NOTE:

- ALL MASONRY LINTELS ARE TO BE GROUTED SOLID
- GROUT WALL ENDS SOLID BELOW LINTEL FOR WIDTH OF 200 mm LINTEL BEARING
- SEE DRAWING S00 FOR MASONRY REINFORCEMENT. PROVIDE 1-20M VERT IN EACH GROUTED CORE AT WALL ENDS EACH SIDE OF LINTEL OPENING UNLESS NOTED OTHERWISE ON PLANS.
- USE LOW WEB BLOCKS FOR LINTEL COURSES CONTAINING HORIZONTAL REBAR

MASONRY WALL SCHEDULE

MARK	THICKNESS/GROUTING	REINFORCING	
		VERT.	HORIZ.
MW1	190mm GROUTED @ 600	15M @ 600 o/c	HL2 @ 200 o/c
MW2	190mm GROUTED @ 400	15M @ 400 o/c	HL2 @ 200 o/c
MW3	190mm GROUTED SOLID	15M @ 400 o/c	HL2 @ 200 o/c

NOTE:

- PROVIDE ADDITIONAL REINFORCING AS FOLLOWS: 1-20M VERT. @ ES OPENINGS, CORNERS & INTERSECTIONS FULLY GROUTED
- ALL BLOCK WALL SECTIONS EQUAL TO OR LESS THAN 800 mm IN LENGTH TO BE FULLY GROUTED AND REINFORCED WITH 15M VERTICAL @ 200 o/c & HL2 @ 200 o/c (UNLESS NOTED OTHERWISE).
- SEE PLANS FOR LOCATIONS & EXTENT OF MW #.
- SEE GENERAL NOTES ON DWG S01 FOR TYPICAL MASONRY WALL REINFORCING UNLESS NOTED OTHERWISE IN SCHEDULE OR ON PLAN.
- SEE PLANS FOR LOCATIONS OF CONTROL JOINTS (NOTED CJ ON PLAN)

LEGEND

H-HEAVY 5 mm LONGITUDINAL WIRES
9 GAUGE CROSS WIRES
L-LADDER TYPE REINFORCEMENT
2-2 LONGITUDINAL WIRES

Ottawa
DEPARTMENT OF CORPORATE SERVICES / SERVICES GÉNÉRAUX
REAL PROPERTY ASSET MANAGEMENT BRANCH
DIRECTION DE LA GESTION DES ACTIFS ET DES BIENS IMMOBILIERS
DESIGN AND CONSTRUCTION DIVISION /
DIVISION DE LA CONCEPTION ET DE LA CONSTRUCTION

GREG GEODES CHIEF CORPORATE SERVICES OFFICER /
CHEF DES SERVICES GÉNÉRAUX
S.A. FINNMORE, O.A.A. DIRECTOR / DIRECTEUR, O.A.O.
ROBERT VAILLANCOURT, O.A.A. MANAGER / GESTIONNAIRE, O.A.O.

FOR / POUR

Dovercourt RECREATION CENTRE

CUNLIFFE
CUNLIFFE & ASSOCIATES
CONSULTING STRUCTURAL ENGINEERS
102-1737 WOODWARD DR. OTTAWA ON K2C 0P9
TEL: (613) 729-7242 FAX: (613) 729-1461
Email: cunliffe@cunliffe.ca

6			
5			
4			
3	ISSUED FOR CONSTRUCTION	2017/09/29	RW
2	ISSUED FOR BUILDING PERMIT	2017/07/25	RW
1	ISSUED FOR INFORMATION	2017/06/23	RW
NUMBER	MILESTONE / FAT SAILLANT	DATE (Y/M/D)	INITIALS
DESIGNED BY / CONÇU PAR	JC	CHECKED BY / VÉRIFIÉ PAR	JC
DRAWN BY / DÉSSINÉ PAR	RW	SCALE / ÉCHELLE	1:50

THIS DRAWING IS THE PROPERTY OF THE CITY OF OTTAWA AND ALL COPYRIGHT IS RESERVED. DIMENSIONS ON DRAWING ARE FOR ESTIMATING PURPOSES ONLY. IT IS THE RESPONSIBILITY OF EACH CONTRACTOR AND SUB-CONTRACTOR OR CONSULTANT TO CHECK AND VERIFY ALL DIMENSIONS AND CONDITIONS ON SITE. NOTIFY OWNER OF ANY ERRORS OR OMISSIONS PRIOR TO COMMENCING THE WORK. DO NOT SCALE THE DRAWINGS.

CE Dessin constitue la propriété de la Ville d'Ottawa et tout droit d'auteur est réservé. Les dimensions utilisées ne sont à des fins d'estimation seulement. Il incombe à chaque entrepreneur, sous-contractant ou consultant de vérifier toutes les dimensions et les conditions sur le chantier. Veuillez informer le propriétaire de toute erreur ou omission avant d'entamer les travaux. Ne dressez pas les plans à l'échelle.

ARCHITECT / ARCHITECTE

CONSULTANT / EXPERT-CONSEIL

LICENCED PROFESSIONAL ENGINEER
R. L. CUNLIFFE
2017-09-29

PROJECT / LOCATION / PROJET / ENDROIT

DOVERCOURT PHASE 2 ADDITION & RENOVATION

411 DOVERCOURT OTTAWA, ONTARIO

DRAWING / DESSIN

FLOOR PLANS LOW ROOF PLAN

FACILITY NO. / NO. DE INSTALLATIONS

SHEET NO. / FEUILLE No.

S103

1713

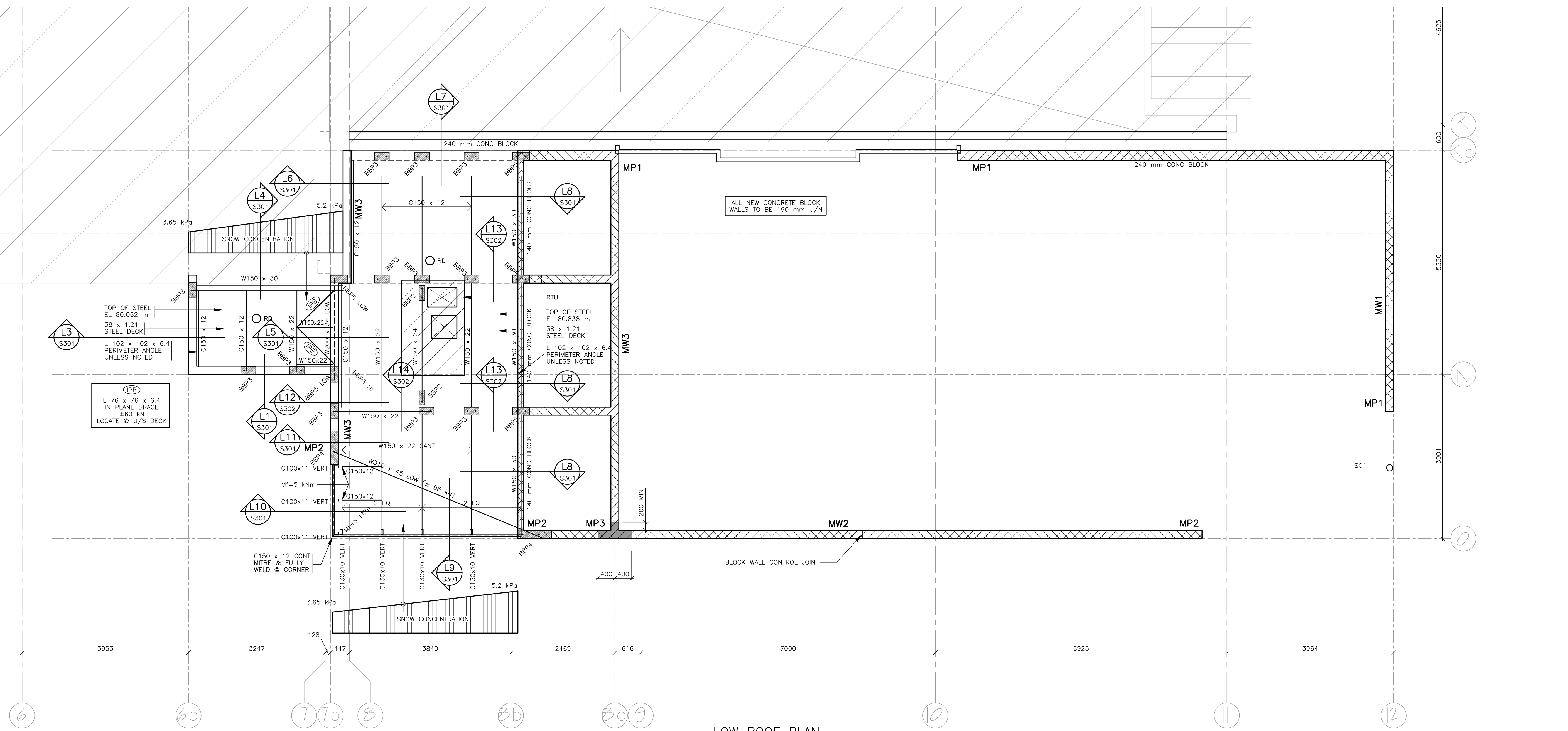

LOW ROOF PLAN
SCALE 1 : 50

NOTE: (AXIAL COLLECTOR LOADS NOTED ON PLANS AS ±#kN)
DESIGN AXIAL COLLECTOR LOADS AND ROLL OVER FORCES (ROF) NOTED ON PLAN HAVE BEEN MULTIPLIED BY Rd=1.5

CONCRETE COMPRESSIVE STRENGTH
SLAB ON DECK - 25 MPa TYPE N

DESIGN LOADS:

TYPICAL STEEL ROOF AREAS	MECHANICAL EQUIPMENT AREAS
ROOF'G & INSUL. 0.65 kPa	CONCRETE CURBS 4.50 kPa
BOARD 0.10	CONCRETE PAD 2.40
STEEL DECK 0.15	ROOF'G & INSUL. 0.60
STRUCTURE 0.20	STEEL DECK 0.15
MECH. & MISC. 0.40	STRUCTURE 0.25
DEAD LOAD 1.50 kPa	CEILING 0.15
SNOW LOAD 2.32 kPa (OR CONCENTRATION)	MECH. & MISC. 2.80
TOTAL LOAD 3.82 kPa (OR DL + CONCEN)	DEAD LOAD 10.85 kPa
	SNOW LOAD 2.32 kPa (OR CONCENTRATION)
	TOTAL LOAD 13.17 kPa U/N (OR DL + CONCEN)



6			
5			
4			
3	ISSUED FOR CONSTRUCTION	2017/09/29	RW
2	ISSUED FOR BUILDING PERMIT	2017/07/25	RW
1	ISSUED FOR INFORMATION	2017/06/23	RW
NUMBER /	MILESTONE / FMT SAILLANT	DATE / (Y/M/D)	INITIALS /
DESIGNED BY / CONÇU PAR		CHECKED BY / VÉRIFIÉ PAR	
JC		JC	
DRAWN BY / DESINÉ PAR		SCALE / ÉCHELLE	
RW		1:50	

THIS DRAWING IS THE PROPERTY OF THE CITY OF OTTAWA AND ALL COPYRIGHT IS RESERVED. DIMENSIONS ON DRAWING ARE FOR ESTIMATING PURPOSES ONLY. IT IS THE RESPONSIBILITY OF EACH CONTRACTOR AND SUB-CONTRACTOR OR CONSULTANT TO CHECK AND VERIFY ALL DIMENSIONS AND CONDITIONS ON SITE. NOTIFY OWNER OF ANY ERRORS OR OMISSIONS PRIOR TO COMMENCING THE WORK. DO NOT SCALE THE DRAWINGS.

CE DESSIN CONSTITUE LA PROPRIÉTÉ DE LA VILLE D'OTTAWA ET TOUT DROIT D'AUTEUR EST RÉSERVÉ. LES DIMENSIONS UTILISÉES SE SONT À DES FINS DESTINATION SEULEMENT. IL INCOMBE À CHAQUE ENTREPRENEUR, SOUS-CONTRACTANT OU CONSULTANT DE VÉRIFIER TOUTES LES DIMENSIONS ET LES CONDITIONS SUR LE CHANTIER. VEUILLEZ INFORMER LE PROPRIÉTAIRE DE TOUTE ERREUR OU OMISSION AVANT D'ENTAMER LES TRAVAUX. NE DRESSÉZ PAS LES PLANS À L'ÉCHELLE.

ARCHITECT / ARCHITECTE

CONSULTANT / EXPERT-CONSEIL

R. L. CUNLIFFE
 LICENSED PROFESSIONAL ENGINEER
 2017-09-29

CONSULTANT / EXPERT-CONSEIL

CONSULTANT / EXPERT-CONSEIL

PROJECT / LOCATION / PROJET / ENDROIT

DOVERCOURT
PHASE 2
ADDITION & RENOVATION

411 DOVERCOURT
 OTTAWA, ONTARIO

DRAWING / DESSIN

FLOOR PLANS
HIGH ROOF PLAN

FACILITY NO. / NO. DE INSTALLATIONS

SHEET NO. / FEUILLE No.

S104

PROJECT NO. / PROJET NO.

1713

BEAM BEARING PLATE SCHEDULE

MARK	SIZE	ANCHORS
BBP3	180 x 350 x 16 THK PLATE	2-15M x 400 Lg WELDABLE REBAR
BBP4	180 x 800 x 25 THK PLATE	4-20M x 800 Lg WELDABLE REBAR
BBP5	180 x 400 x 25 THK PLATE	2-15M x 400 Lg WELDABLE REBAR
BBP6	100 x 12 THK PLATE CONT	1-15M x 400 Lg WELDABLE REBAR SPACED @ 600 o/c

NOTES:

- BEAMS SUPPORTED ON BEAM BEARING BASE PLATES TO EXTEND ONTO PLATE A MINIMUM OF 80% LENGTH OF PLATE, IN DIRECTION OF BEAM UNLESS NOTED OTHERWISE ON PLAN.
- ANCHORS ARE TO BE CENTERED ON PLATE & SPACED AT 200 o/c TO ALIGN WITH CORE VOIDS IN BLOCK UNLESS OTHERWISE NOTED
- ENSURE BEAM POCKETS IN MASONRY WALLS ARE BUILT-IN WITH MASONRY OR GROUTED SOLID.
- ENSURE WALLS ARE GROUTED AT LEAST 3 COURSES BELOW BEAM BEARING PLATES.

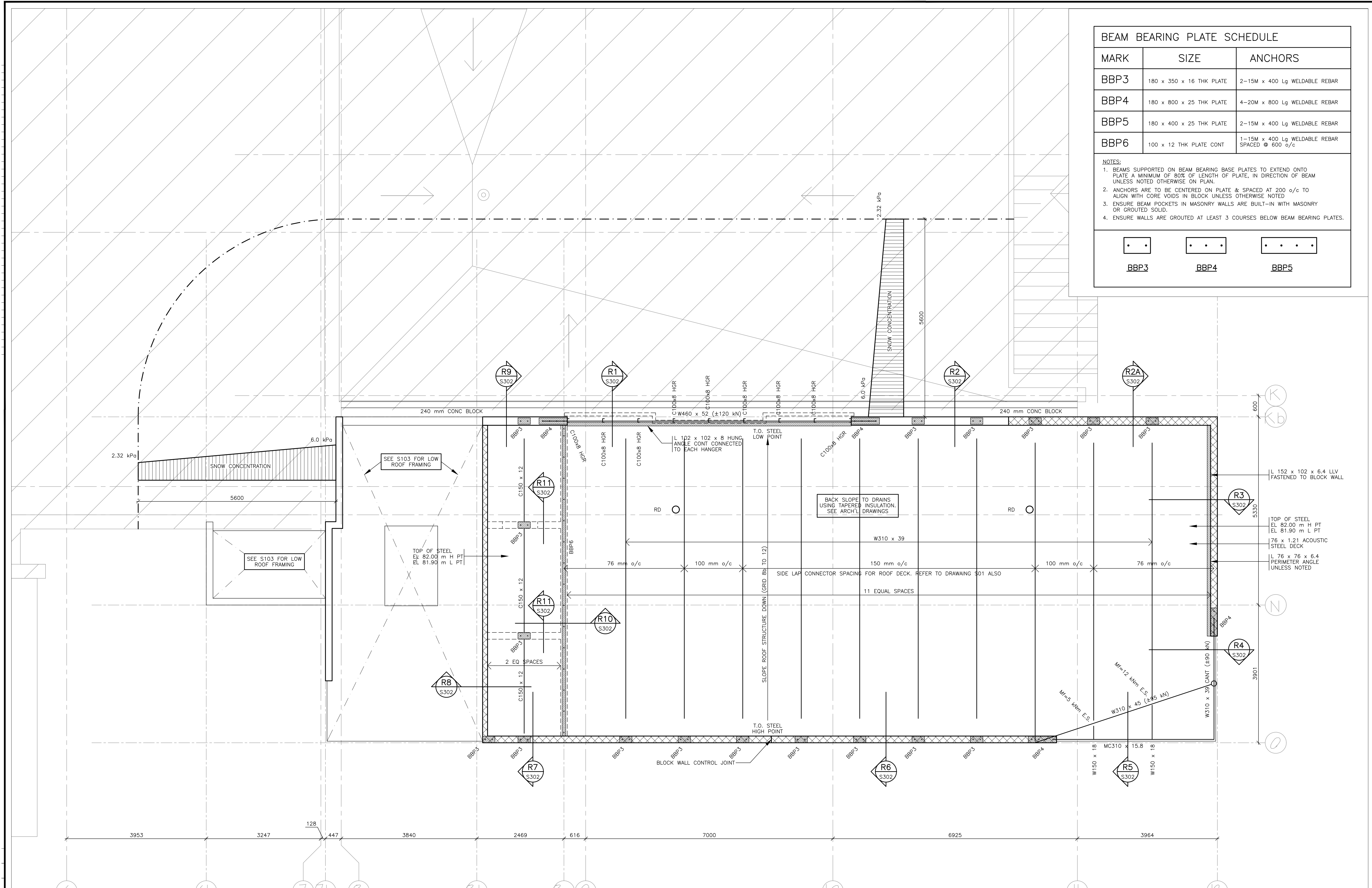

HIGH ROOF PLAN
 SCALE 1 : 50

NOTE: (AXIAL COLLECTOR LOADS NOTED ON PLANS AS ±#kN)

DESIGN AXIAL COLLECTOR LOADS NOTED ON PLAN HAVE BEEN MULTIPLIED BY **Rd=1.5**

DESIGN LOADS:

TYPICAL STEEL ROOF AREAS	
ROOF'S & INSUL.	0.65 kPa
BOARD	0.10
STEEL DECK	0.15
STRUCTURE	0.20
MECH. & MISC.	0.40
DEAD LOAD	1.50 kPa
SNOW LOAD	2.32 kPa (OR CONCENTRATION)
TOTAL LOAD	3.82 kPa (OR DL + CONCEN)



6			
5			
4			
3	ISSUED FOR CONSTRUCTION	2017/09/29	RW
2	ISSUED FOR BUILDING PERMIT	2017/07/25	RW
1	ISSUED FOR INFORMATION	2017/06/22	RW
NUMBER / NUMÉRO	MILESTONE / ÉTAT SÉRIANT	DATE / DATE (MM/JJ)	INITIALS / INITIALES

DESIGNED BY / CONÇU PAR JC	CHECKED BY / VÉRIFIÉ PAR JC
DRAWN BY / DÉSSINÉ PAR RW	SCALE / ÉCHELLE 1:50

DETAIL NUMBER 1	DRAWING TITLE
SCALE A1:1	
SHEET NUMBER	

THIS DRAWING IS THE PROPERTY OF THE CITY OF OTTAWA AND ALL COPYRIGHT IS RESERVED. DIMENSIONS ON DRAWING ARE FOR ESTIMATING PURPOSES ONLY. IT IS THE RESPONSIBILITY OF EACH CONTRACTOR AND SUB-CONTRACTOR OR CONSULTANT TO CHECK AND VERIFY ALL DIMENSIONS AND CONDITIONS ON SITE. NOTIFY OWNER OF ANY ERRORS OR OMISSIONS PRIOR TO COMMENCING THE WORK. DO NOT SCALE THE DRAWINGS.

CE DESSIN CONSTITUE LA PROPRIÉTÉ DE LA VILLE D'OTTAWA ET TOUT DROIT D'AUTEUR EST RÉSERVÉ. LES DIMENSIONS UTILISÉES SEULEMENT À DES FINS D'ESTIMATION SEULEMENT. IL INCOMBE À CHAQUE ENTREPRENEUR, SOUS-CONTRACTANT OU CONSULTANT DE VÉRIFIER TOUTES LES DIMENSIONS ET LES CONDITIONS SUR LE CHANTIER. VÉJUILLEZ INFORMER LE PROPRIÉTAIRE DE TOUTE ERREUR OU OMISSION AVANT D'ENTAMER LES TRAVAUX. NE DRESSÉZ PAS LES PLANS À L'ÉCHELLE.

ARCHITECT / ARCHITECTE

CONSULTANT / EXPERT-CONSEIL

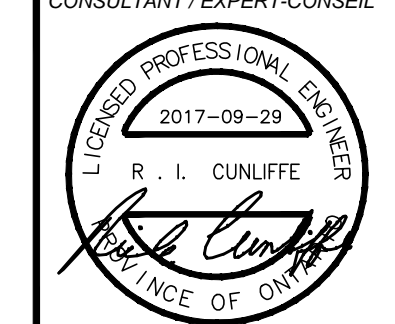

CONSULTANT / EXPERT-CONSEIL

CONSULTANT / EXPERT-CONSEIL

PROJECT / LOCATION / PROJET / ENDROIT

DOVERCOURT
PHASE 2
ADDITION & RENOVATION
 411 DOVERCOURT
 OTTAWA, ONTARIO

DRAWING / DESSIN

SECTIONS

FACILITY NO. / NO. DE INSTALLATIONS

SHEET NO. / FEUILLE No.

PROJECT NO. / PROJET No.

S200

1713

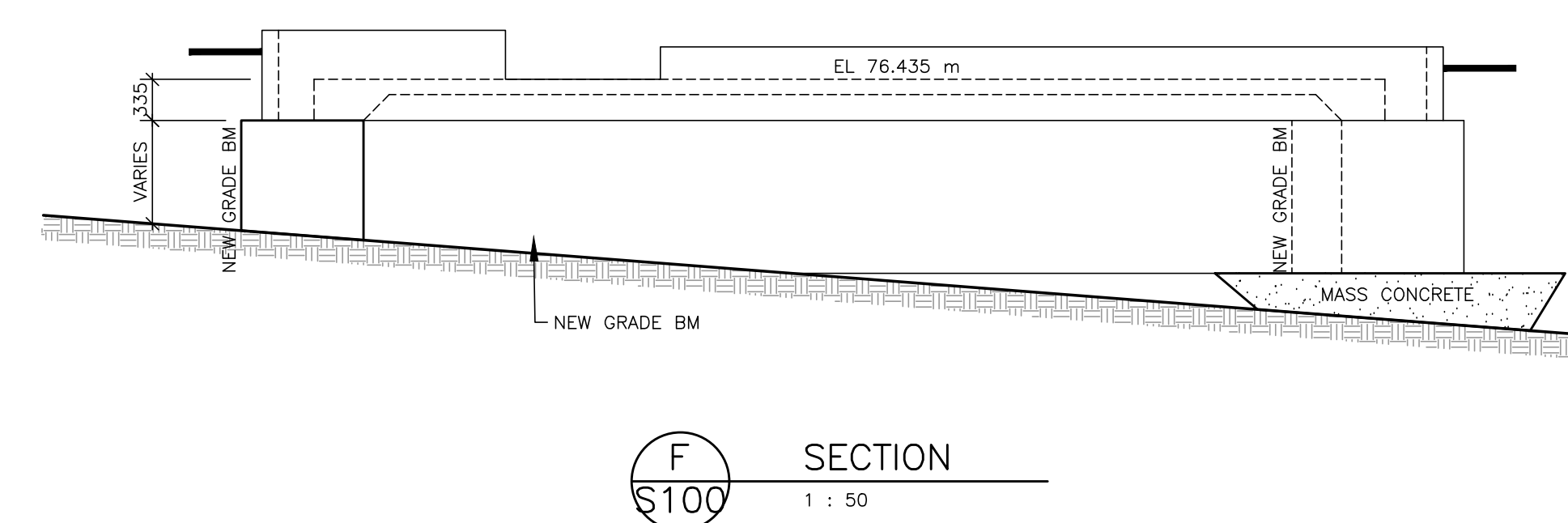

F
S100
 SECTION
 1 : 50

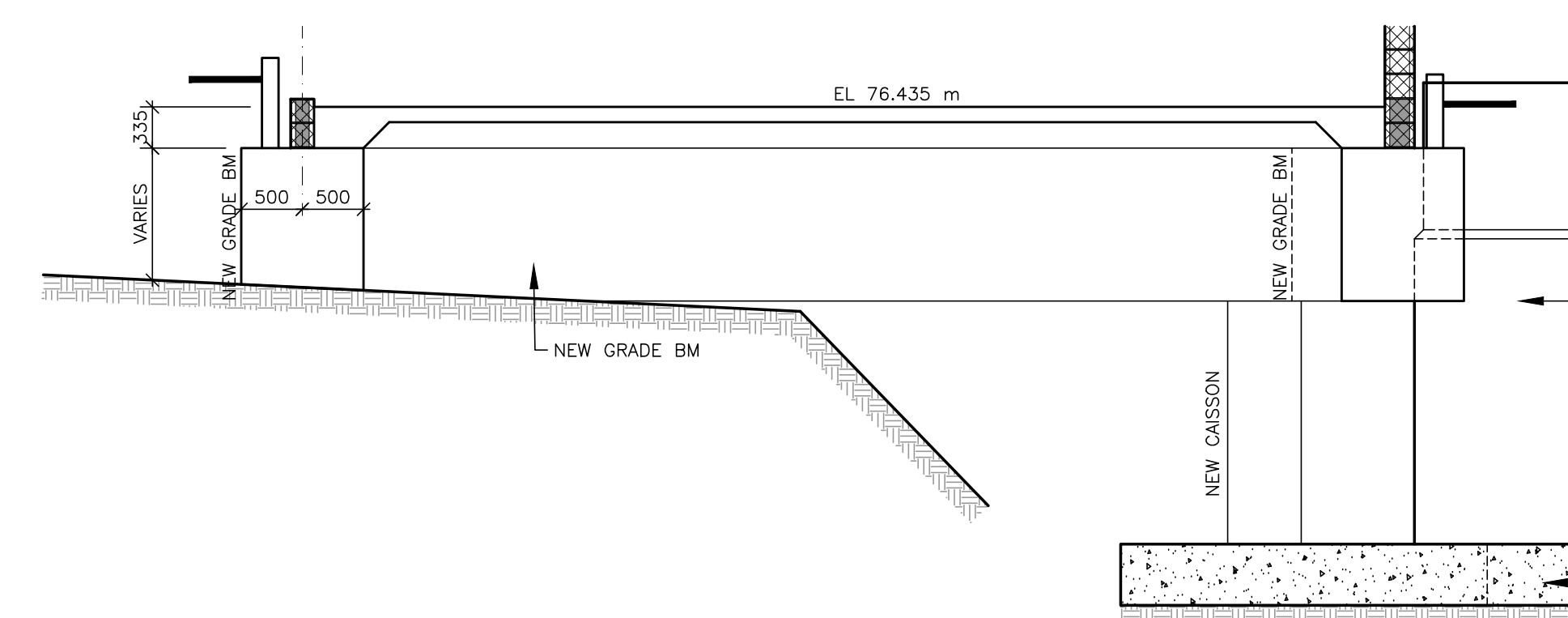

E
S100
 SECTION
 1 : 50

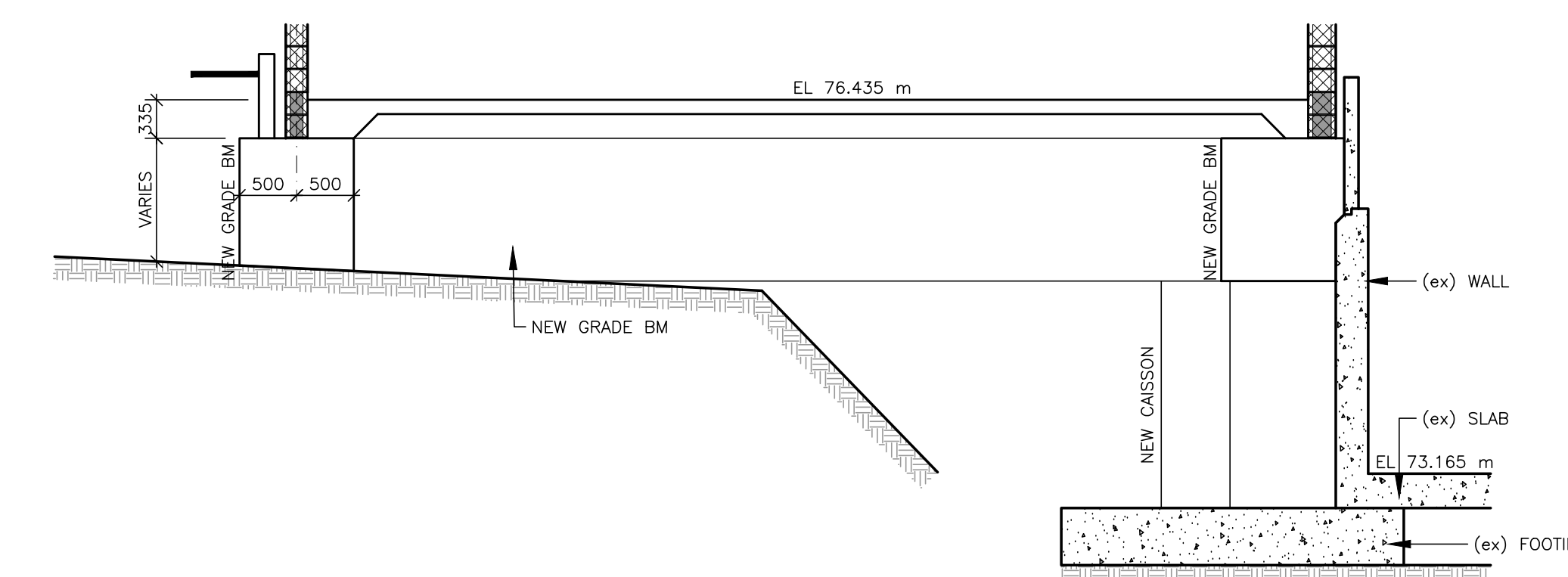

D
S100
 SECTION
 1 : 50

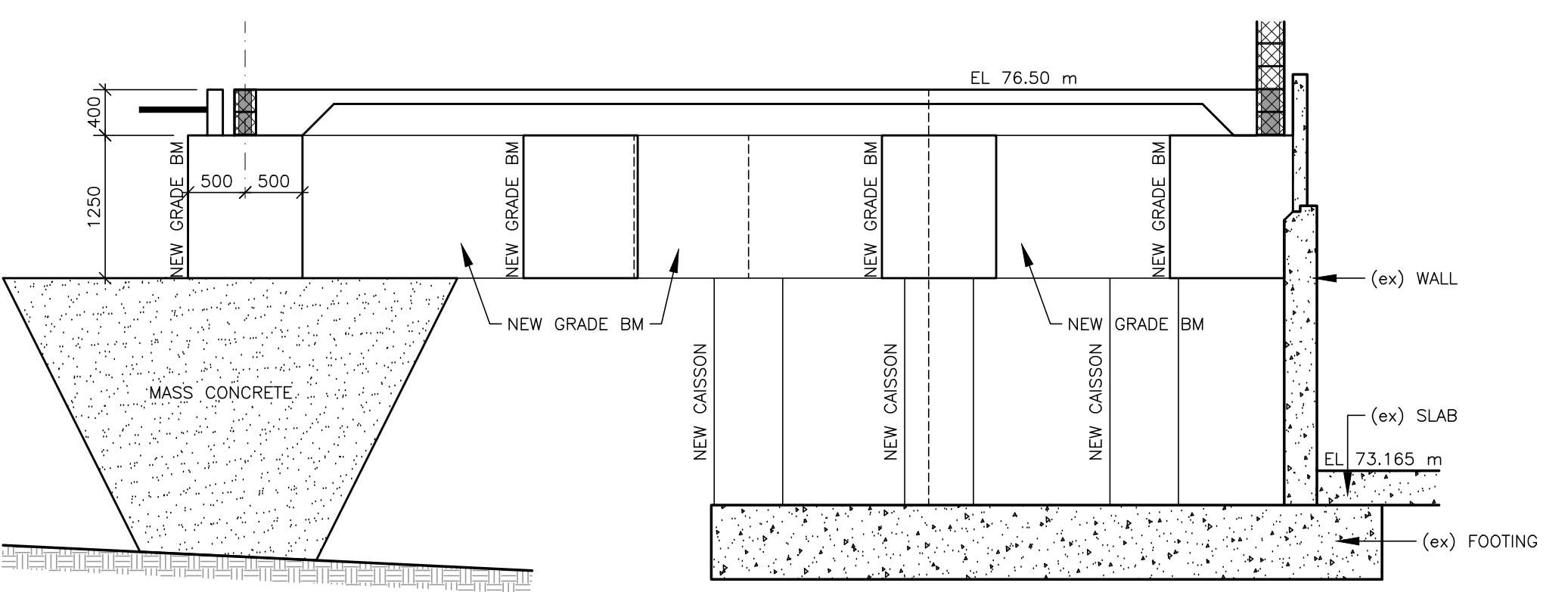

B
S100
 SECTION
 1 : 50

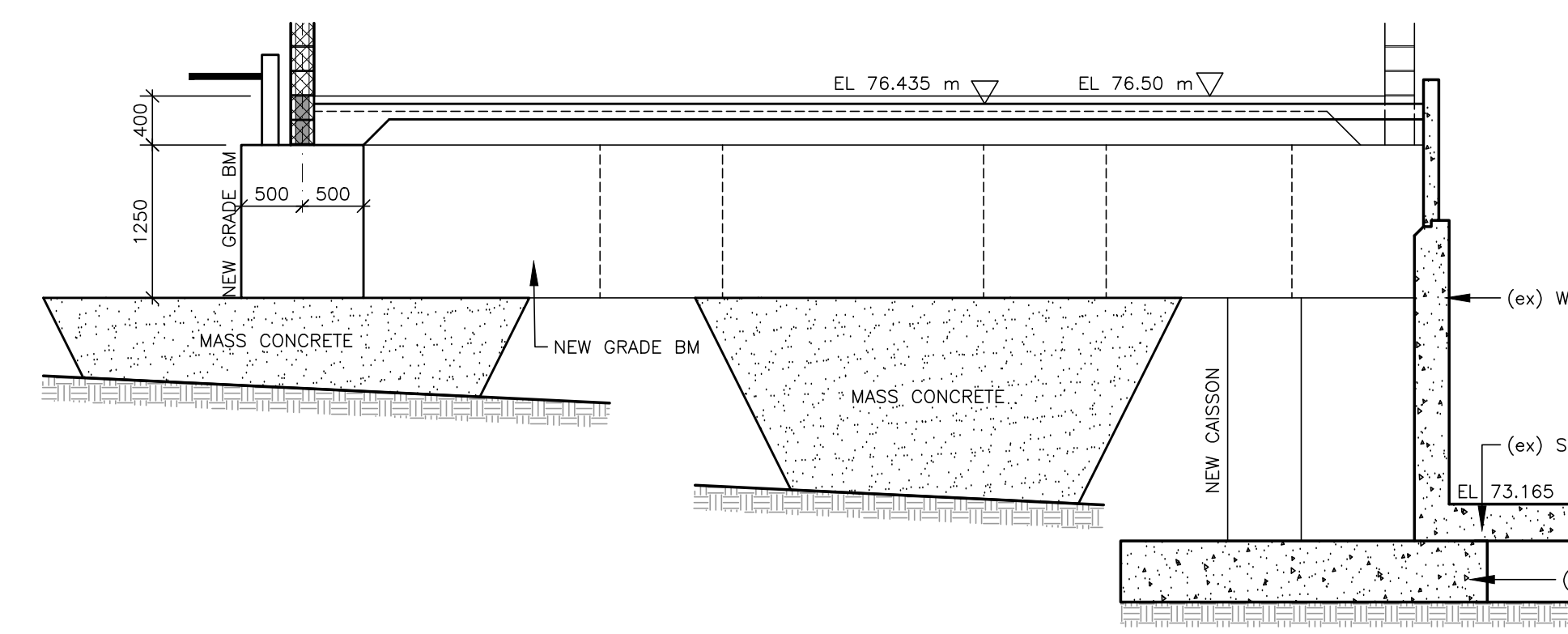

C
S100
 SECTION
 1 : 50

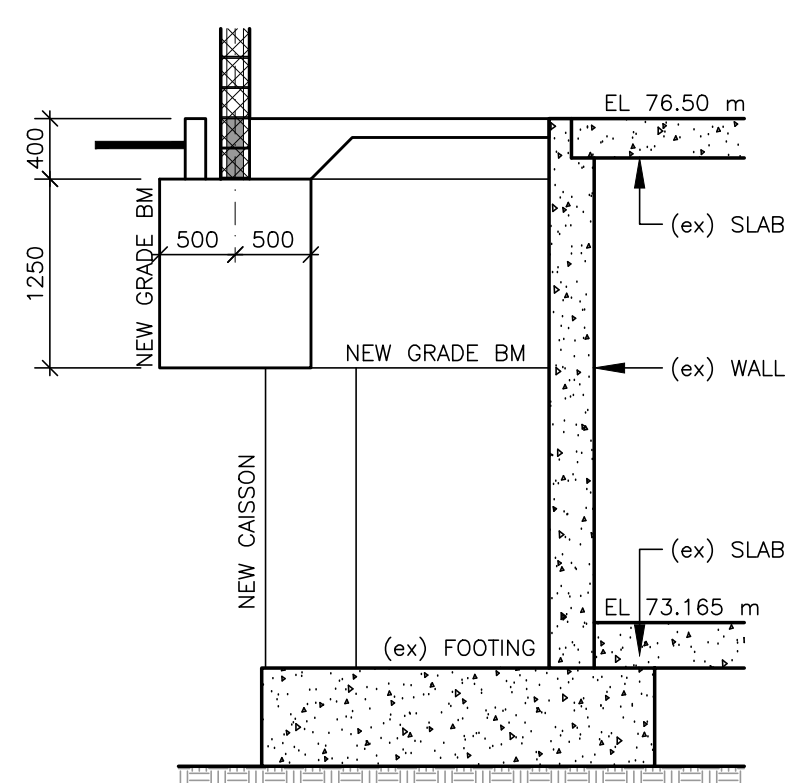

A
S100
 SECTION
 1 : 50



NUMBER	DATE	BY	REVISION
6			
5			
4			
3	2017/09/29	RW	ISSUED FOR CONSTRUCTION
2	2017/07/25	RW	ISSUED FOR BUILDING PERMIT
1	2017/06/23	RW	ISSUED FOR INFORMATION

DESIGNED BY / CONÇU PAR JC	CHECKED BY / VÉRIFIÉ PAR JC
DRAWN BY / DÉSSINÉ PAR RW	SCALE / ÉCHELLE 1:50

DETAIL NUMBER 1	DRAWING TITLE SECTIONS & DETAILS
--------------------	-------------------------------------

THIS DRAWING IS THE PROPERTY OF THE CITY OF OTTAWA AND ALL COPYRIGHT IS RESERVED. DIMENSIONS ON DRAWING ARE FOR ESTIMATING PURPOSES ONLY. IT IS THE RESPONSIBILITY OF EACH CONTRACTOR AND SUB-CONTRACTOR OR CONSULTANT TO CHECK AND VERIFY ALL DIMENSIONS AND CONDITIONS ON SITE. NOTIFY OWNER OF ANY ERRORS OR OMISSIONS PRIOR TO COMMENCING THE WORK. DO NOT SCALE THE DRAWINGS.

CE DESSIN CONSTITUE LA PROPRIÉTÉ DE LA VILLE D'OTTAWA ET TOUT DROIT DE COPYRIGHT EST RÉSERVÉ. LES DIMENSIONS UTILISÉES SE SONT À DES FINS DESTINATION SEULEMENT. IL INCOMBE À CHAQUE ENTREPRENEUR, SOUS-CONTRACTANT OU CONSULTANT DE VÉRIFIER TOUTES LES DIMENSIONS ET LES CONDITIONS SUR LE CHANTIER. VEUILLEZ INFORMER LE PROPRIÉTAIRE DE TOUTE ERREUR OU OMISSION AVANT D'ENTAMER LES TRAVAUX. NE DRESSÉZ PAS LES PLANS À L'ÉCHELLE.

ARCHITECT / ARCHITECTE	CONSULTANT / EXPERT-CONSEIL
------------------------	-----------------------------

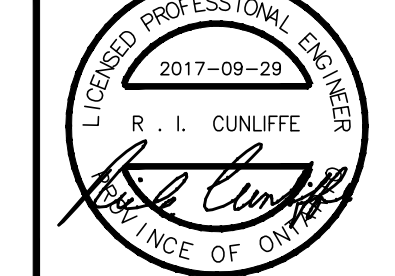

CONSULTANT / EXPERT-CONSEIL	CONSULTANT / EXPERT-CONSEIL
-----------------------------	-----------------------------

PROJECT / LOCATION / PROJET / ENDROIT

DOVERCOURT
PHASE 2
ADDITION & RENOVATION

411 DOVERCOURT
 OTTAWA, ONTARIO

DRAWING / DESSIN
SECTIONS & DETAILS

FACILITY NO. / NO. DE INSTALLATIONS	SHEET NO. / FEUILLE No.
-------------------------------------	-------------------------

PROJECT NO. / PROJET NO.
S300

1713

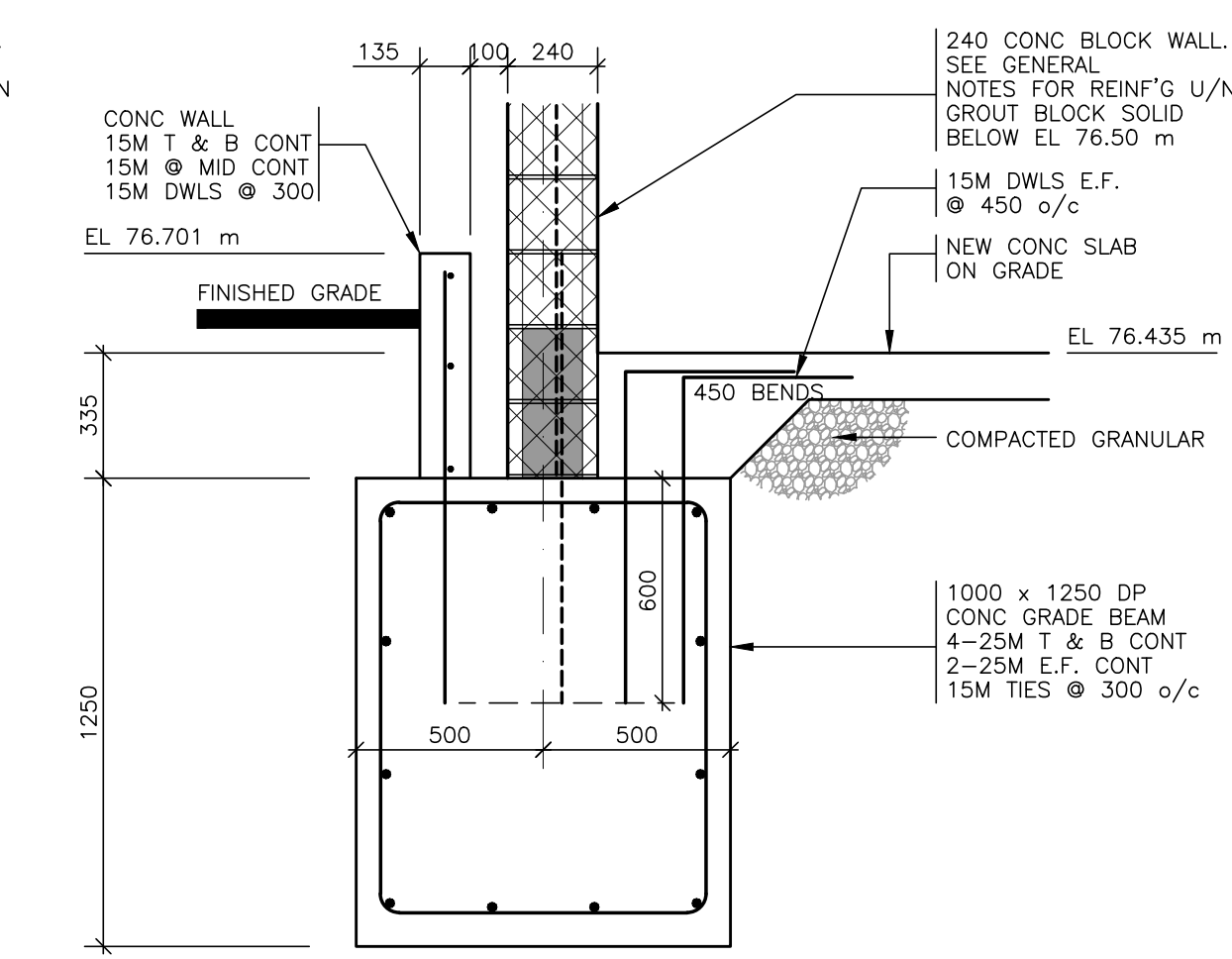

8 SECTION
 S100 1:20

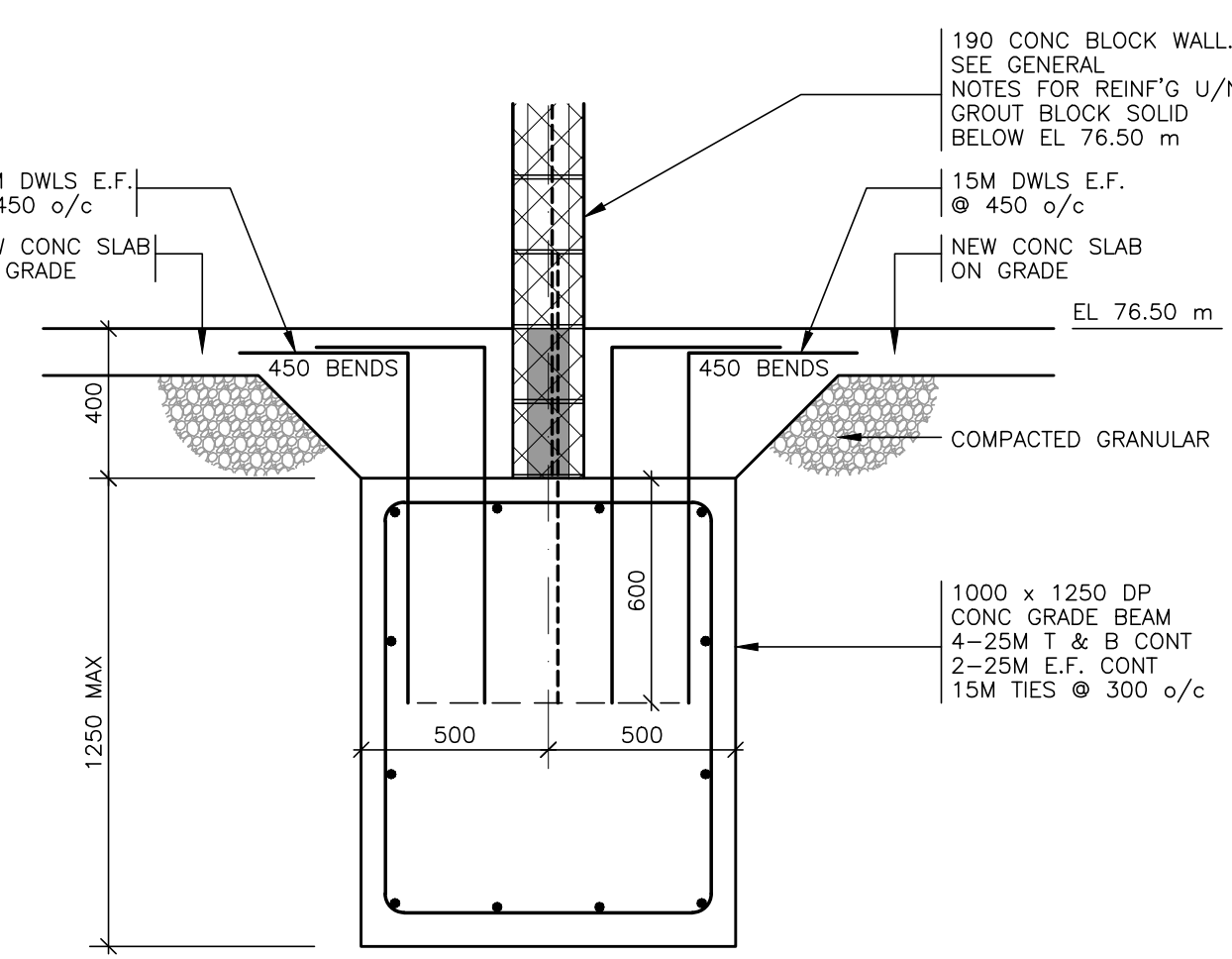

9 SECTION
 S100 1:20

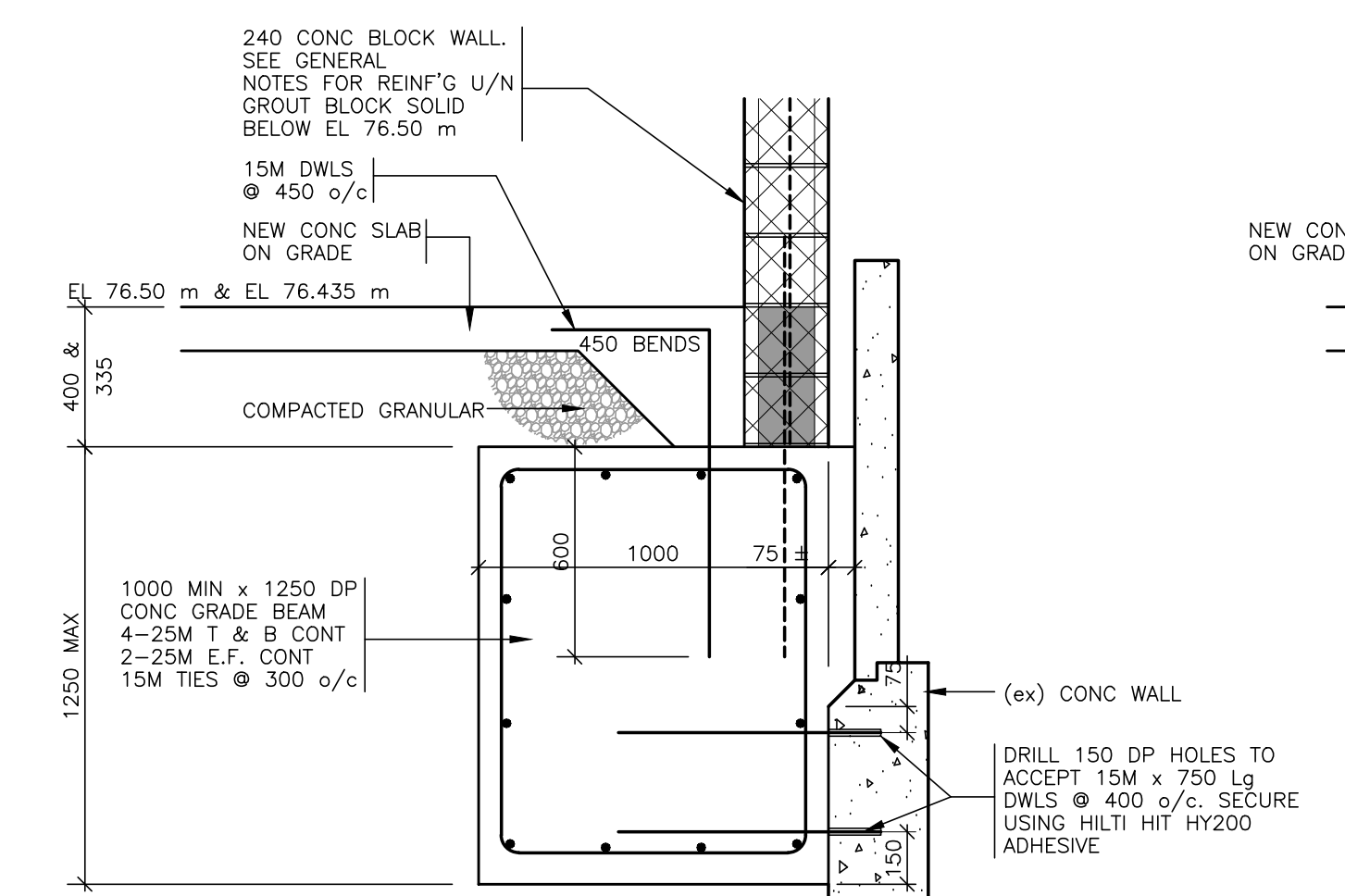

1 SECTION
 S100 1:20

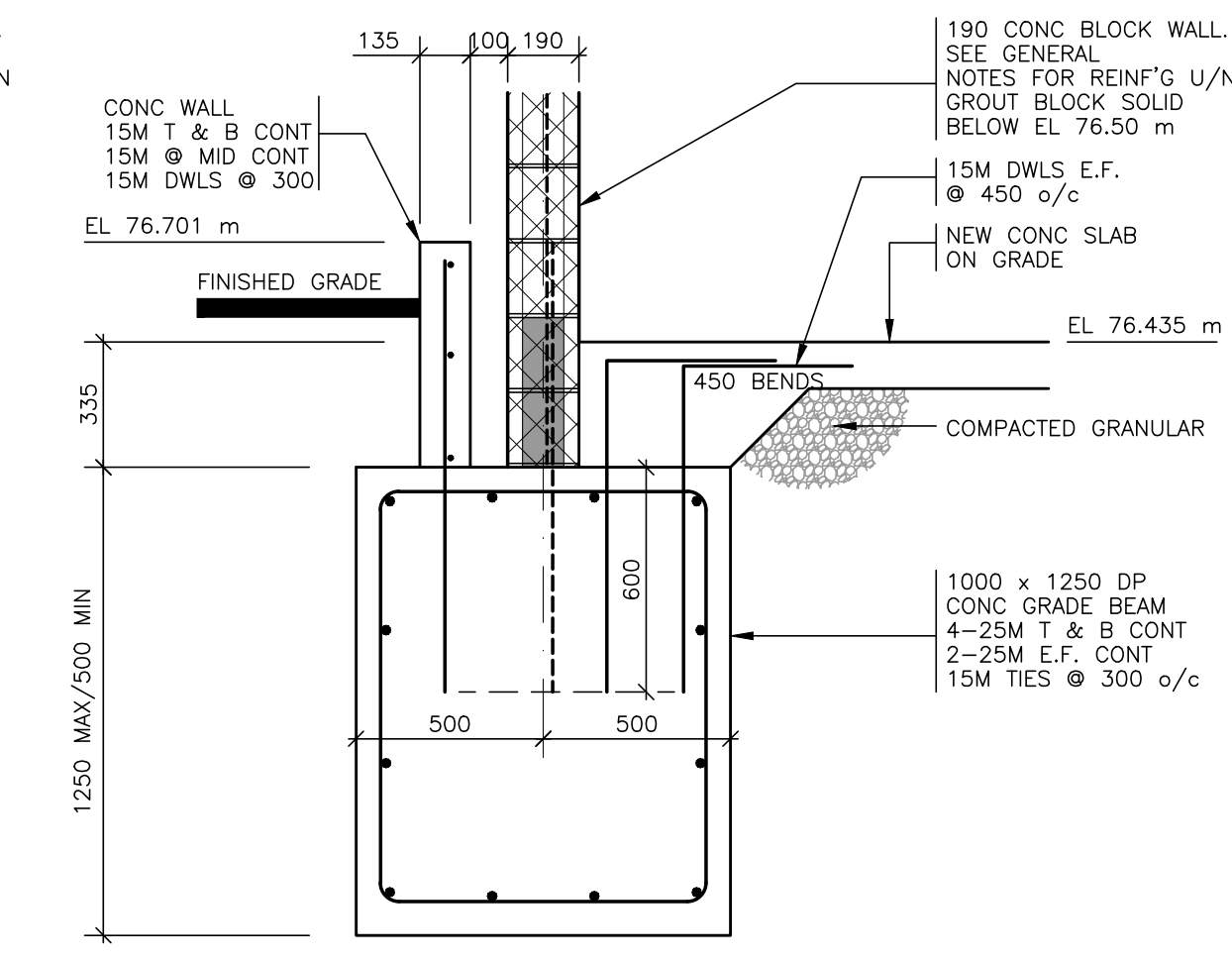

7 SECTION
 S100 1:20

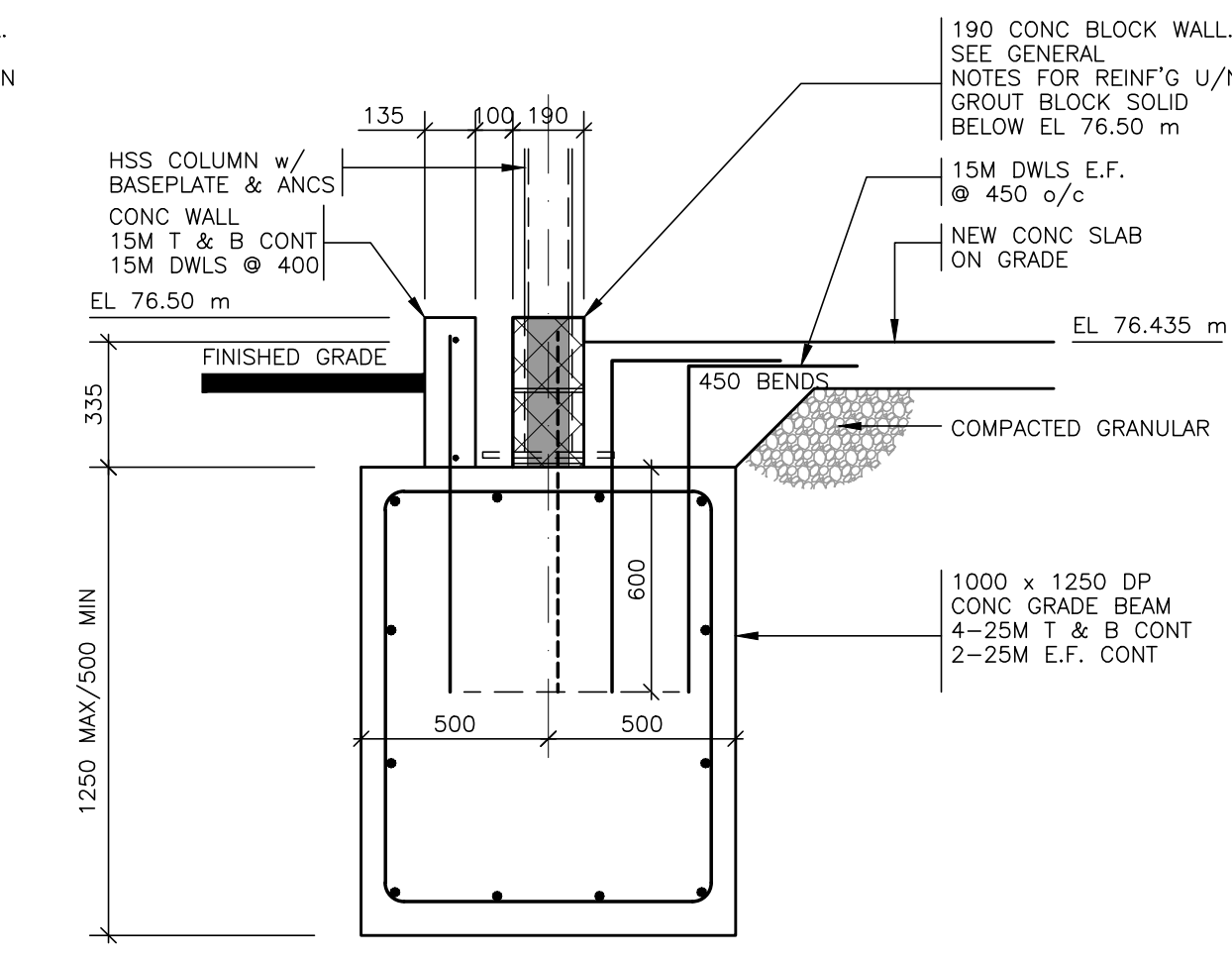

6 SECTION
 S100 1:20

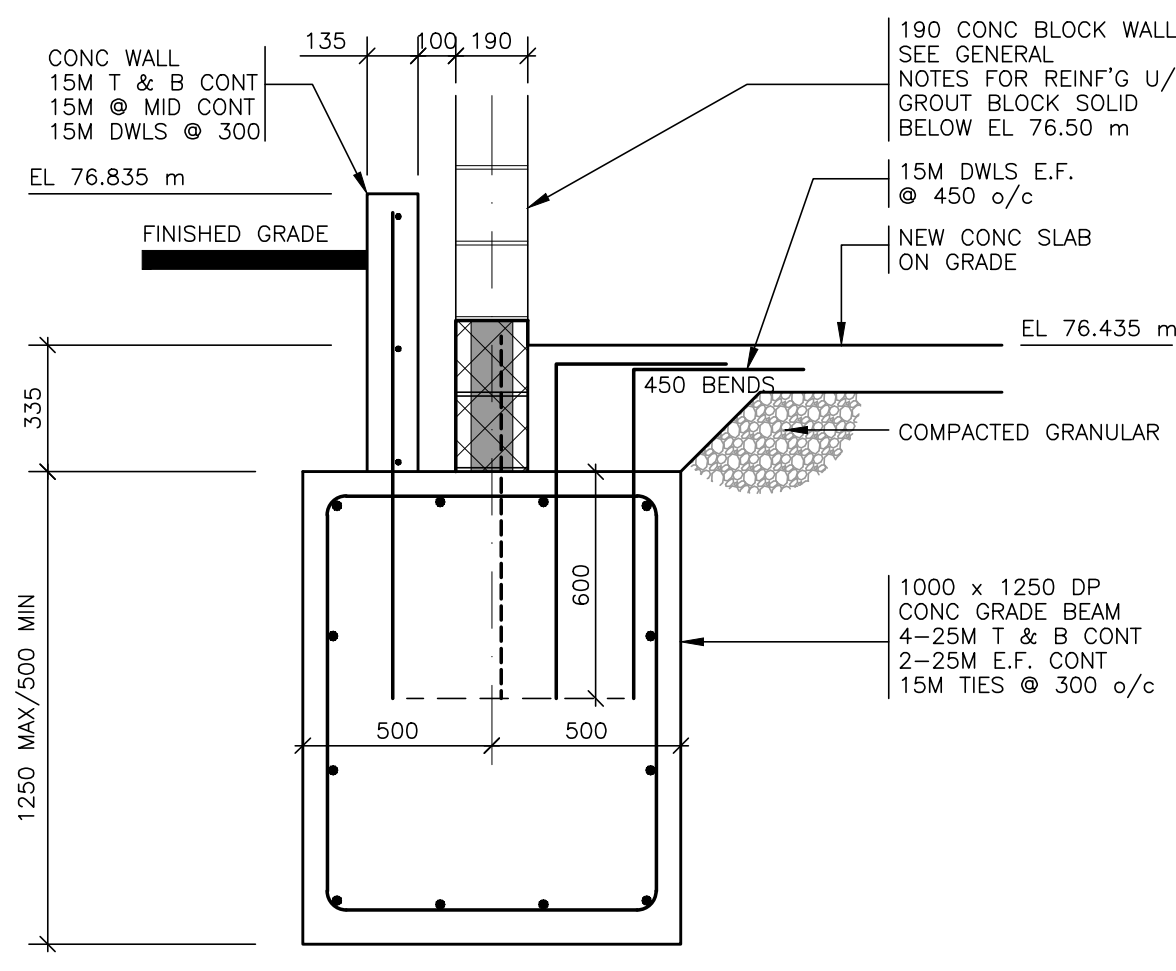

5 SECTION
 S100 1:20

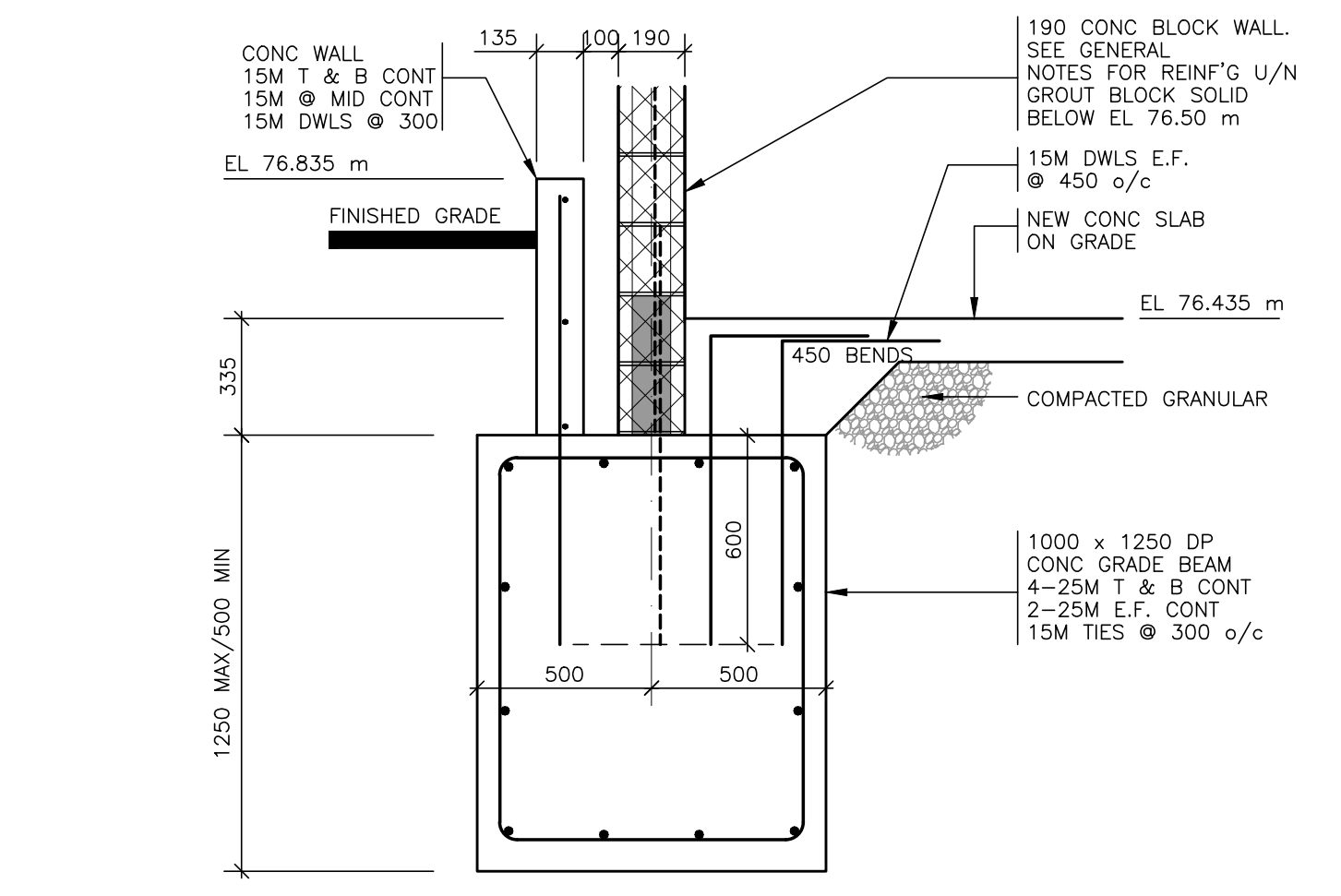

4 SECTION
 S100 1:20

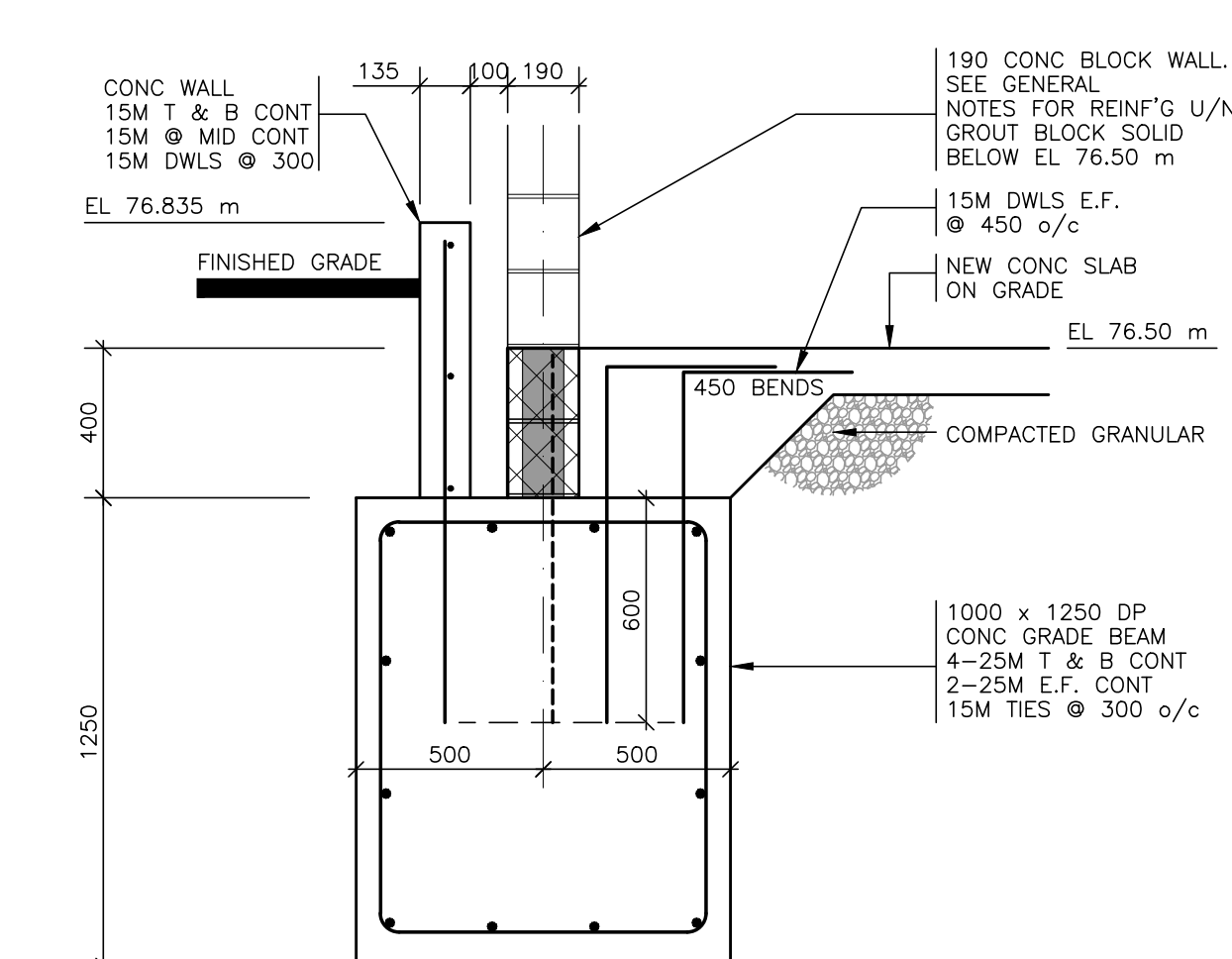

3 SECTION
 S100 1:20

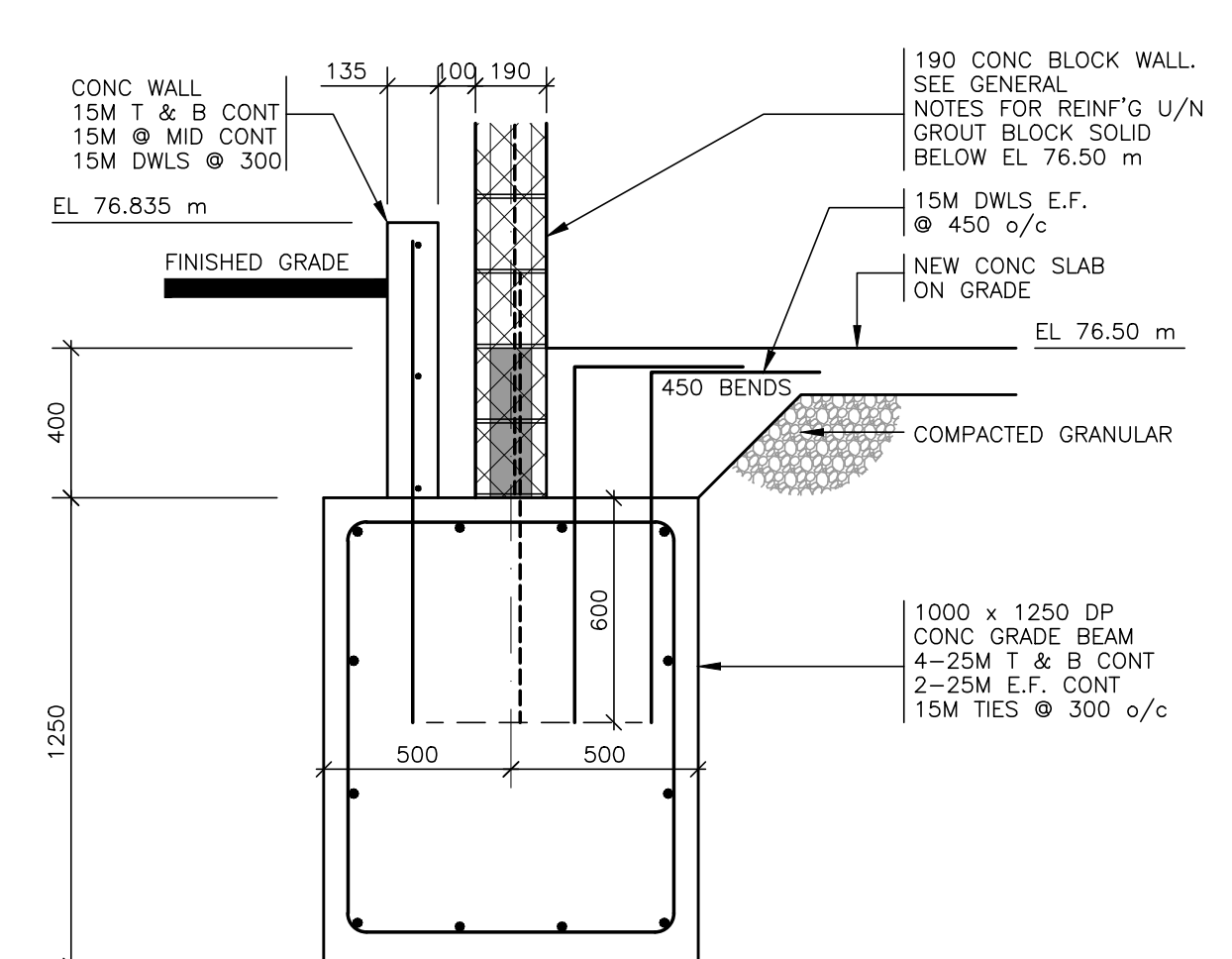

2A SECTION
 S100 1:20

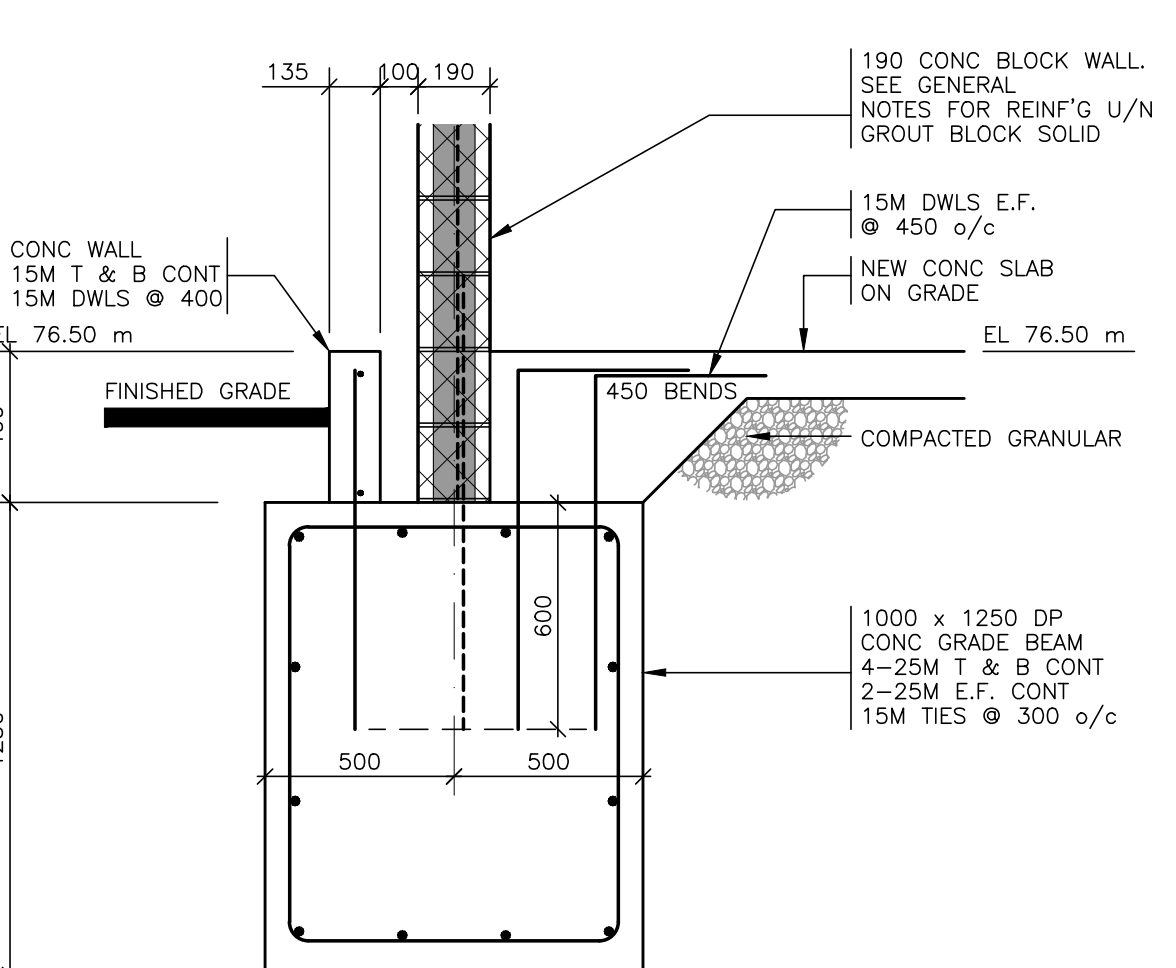

2 SECTION
 S100 1:20

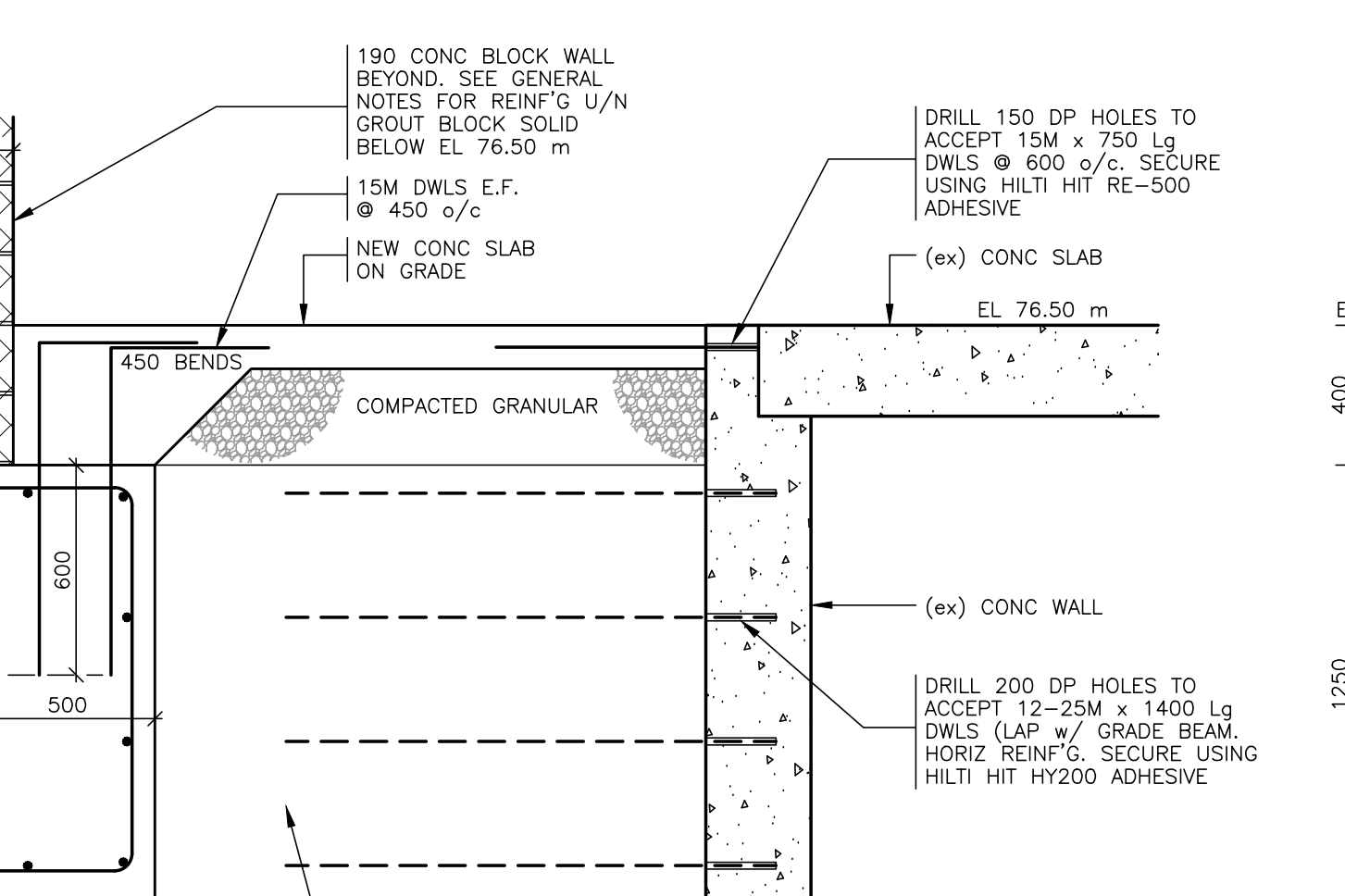

9 SECTION
 S100 1:20

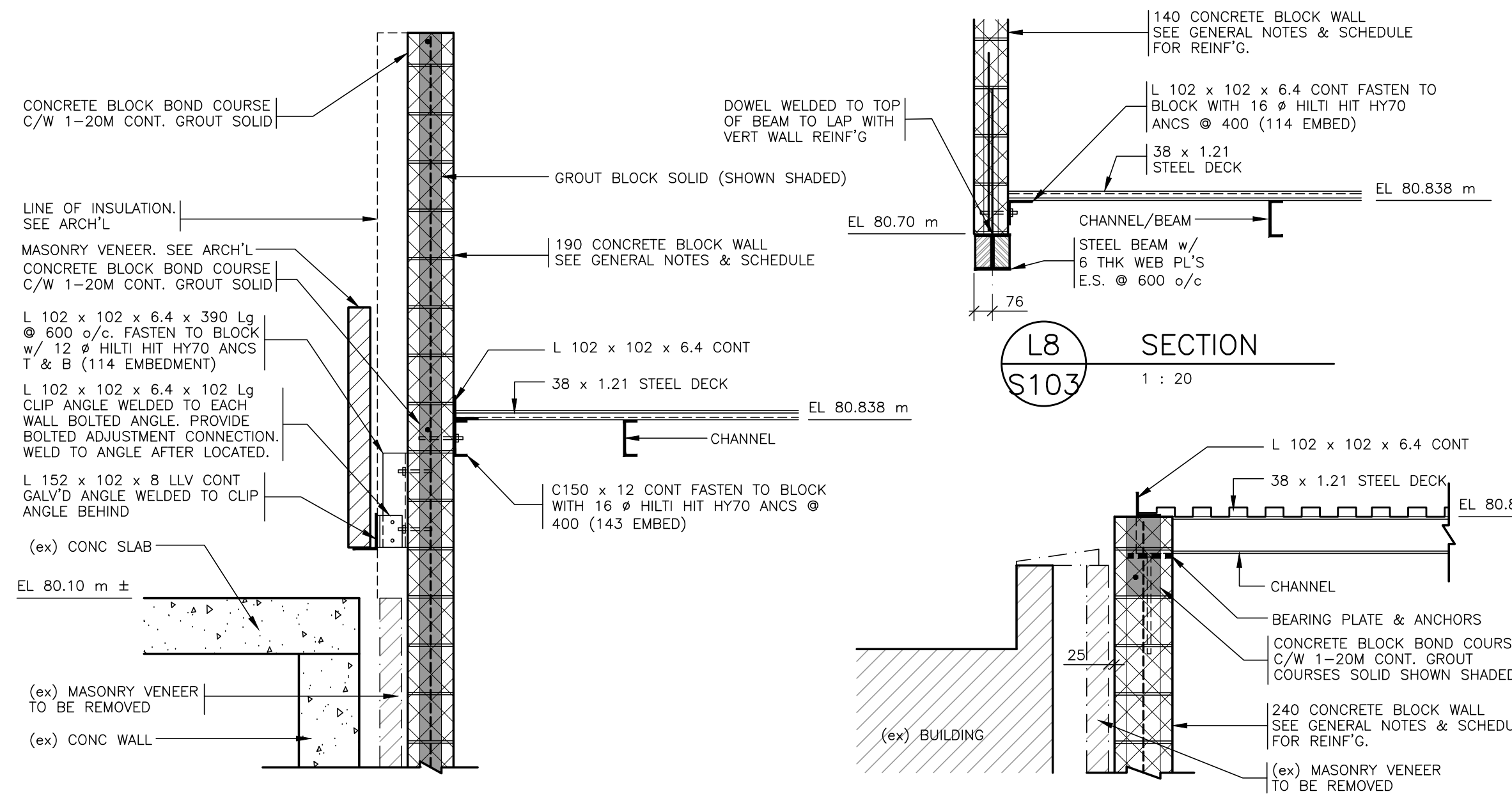

L6 SECTION
S103 1:20

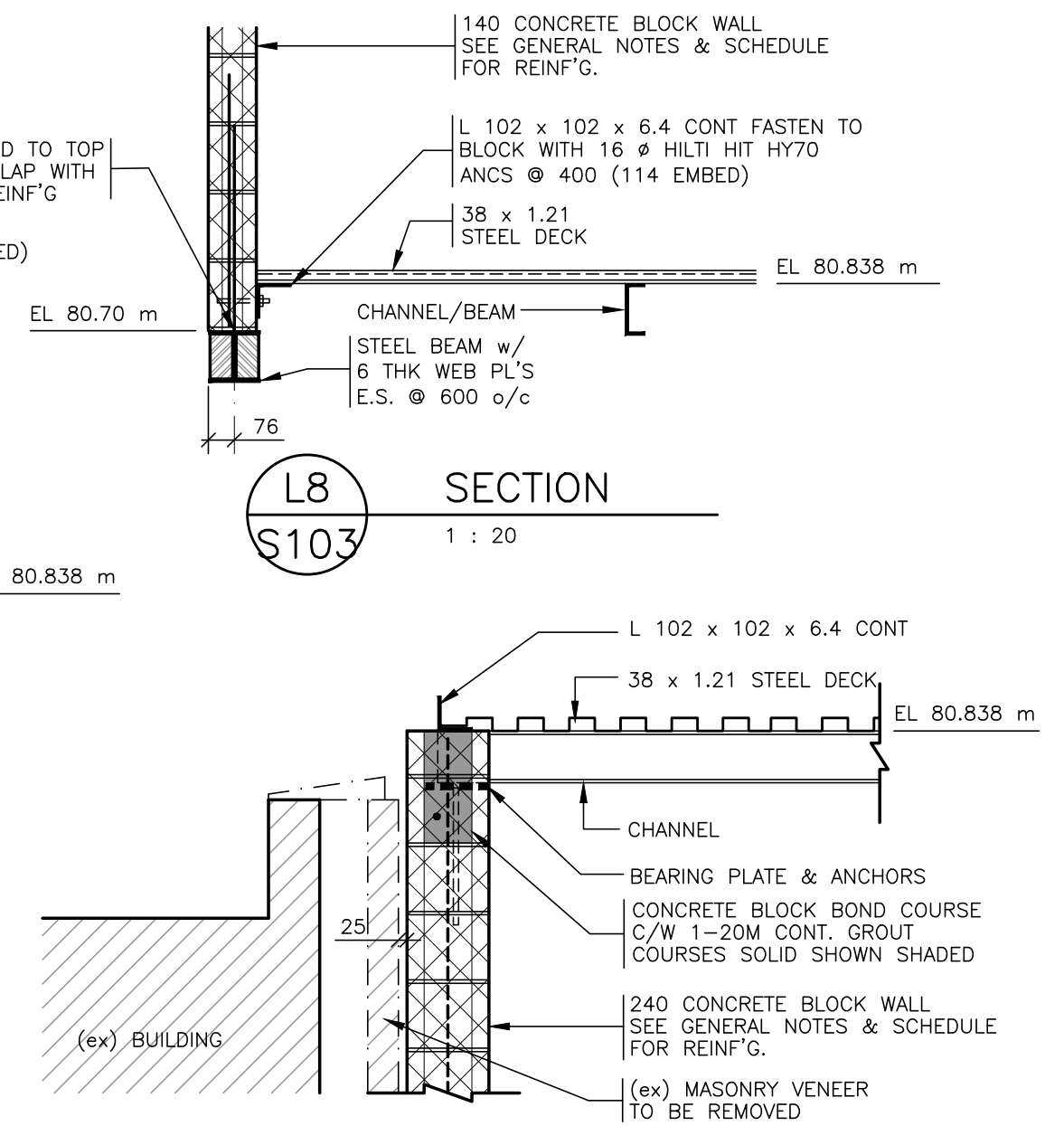

L7 SECTION
S103 1:20

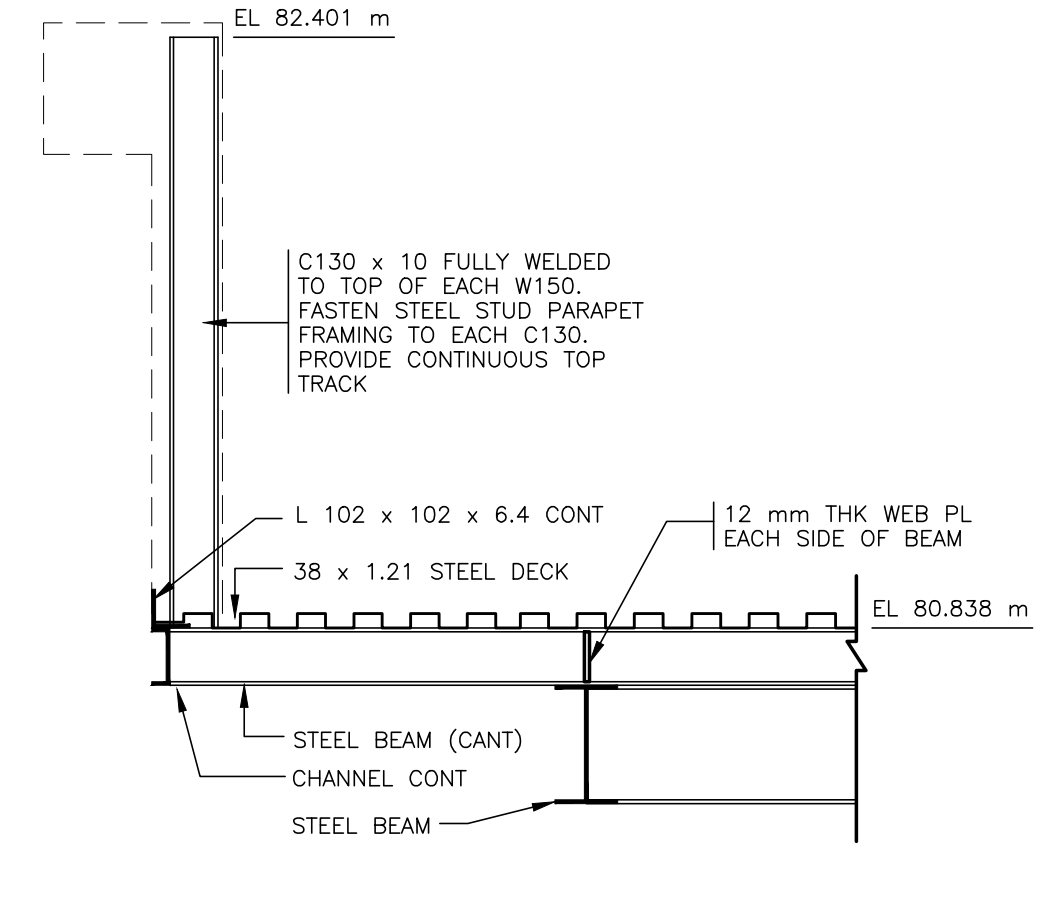

L9 SECTION
S103 1:20

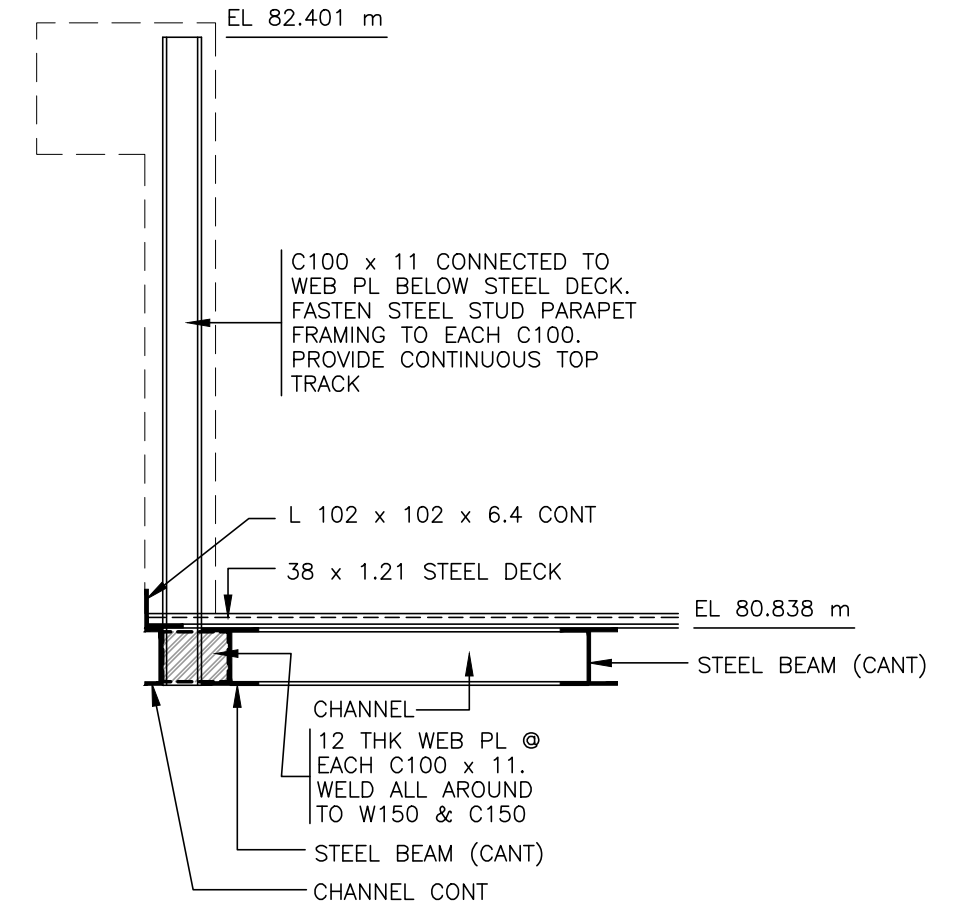

L10 SECTION
S103 1:20

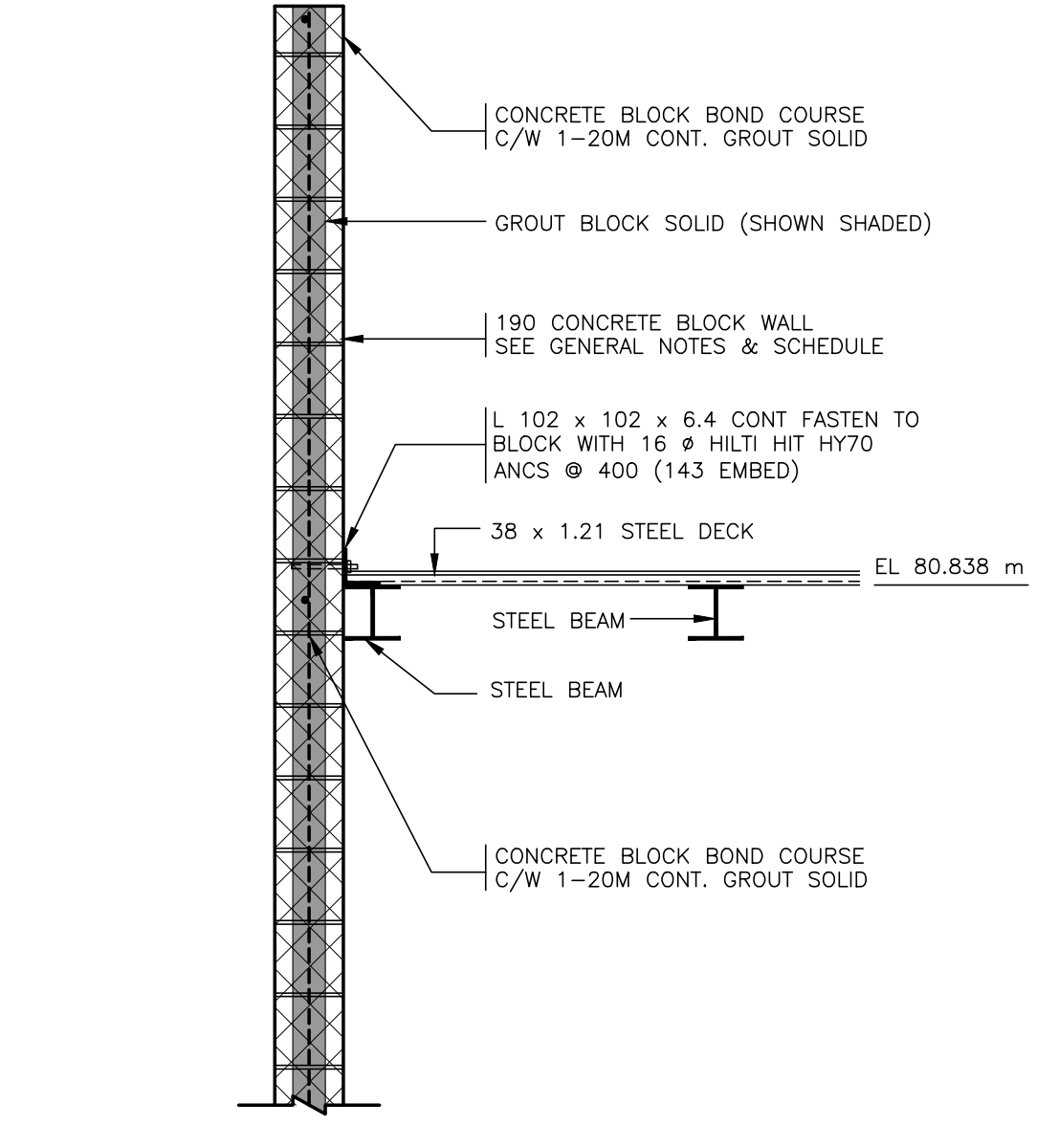

L11 SECTION
S103 1:20

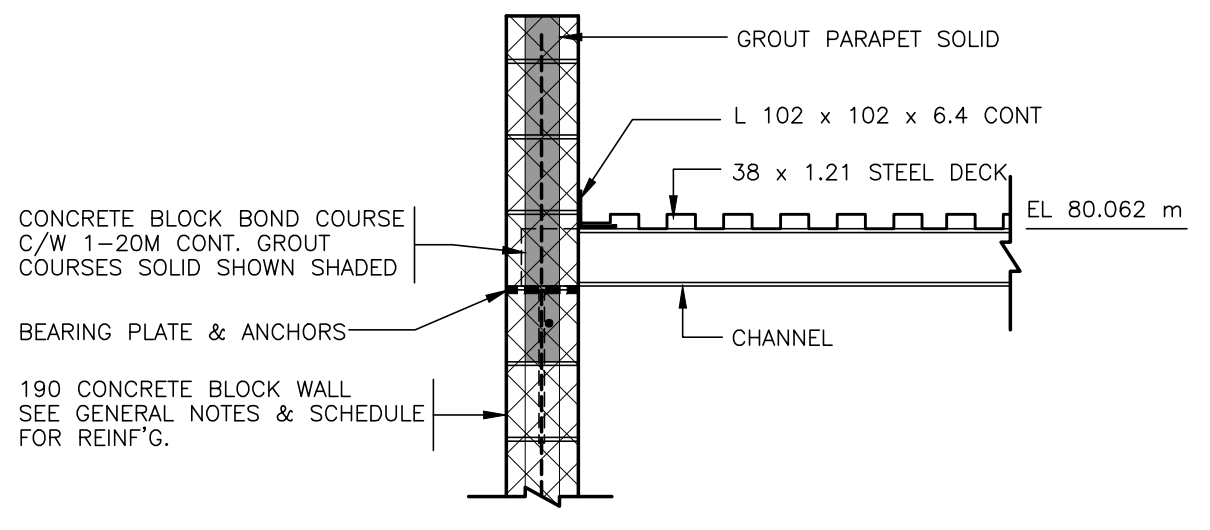

L1 SECTION
S103 1:20



L2 SECTION—RESERVED
S103 1:20

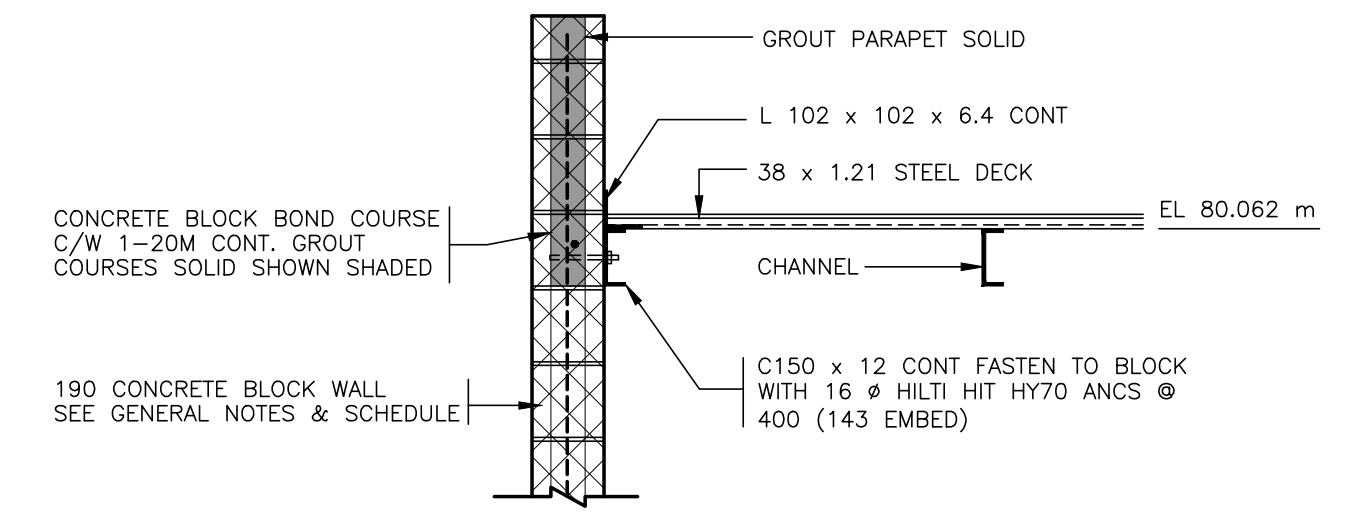

L3 SECTION
S103 1:20

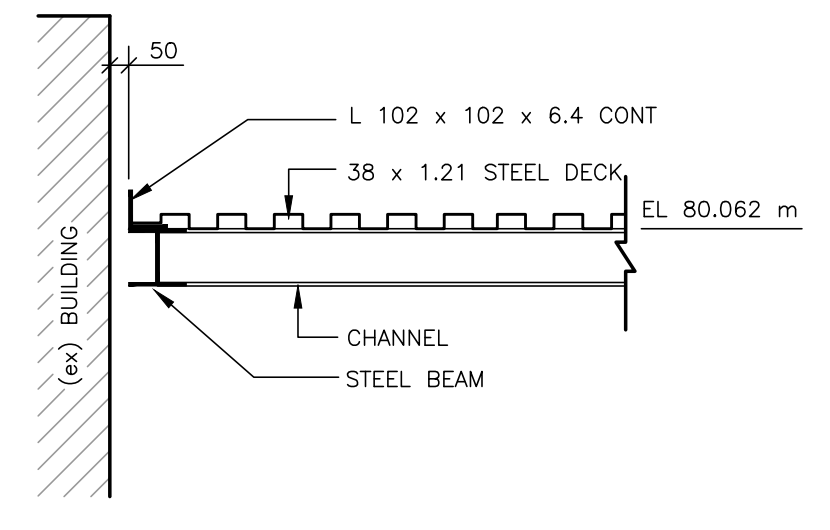

L4 SECTION
S103 1:20

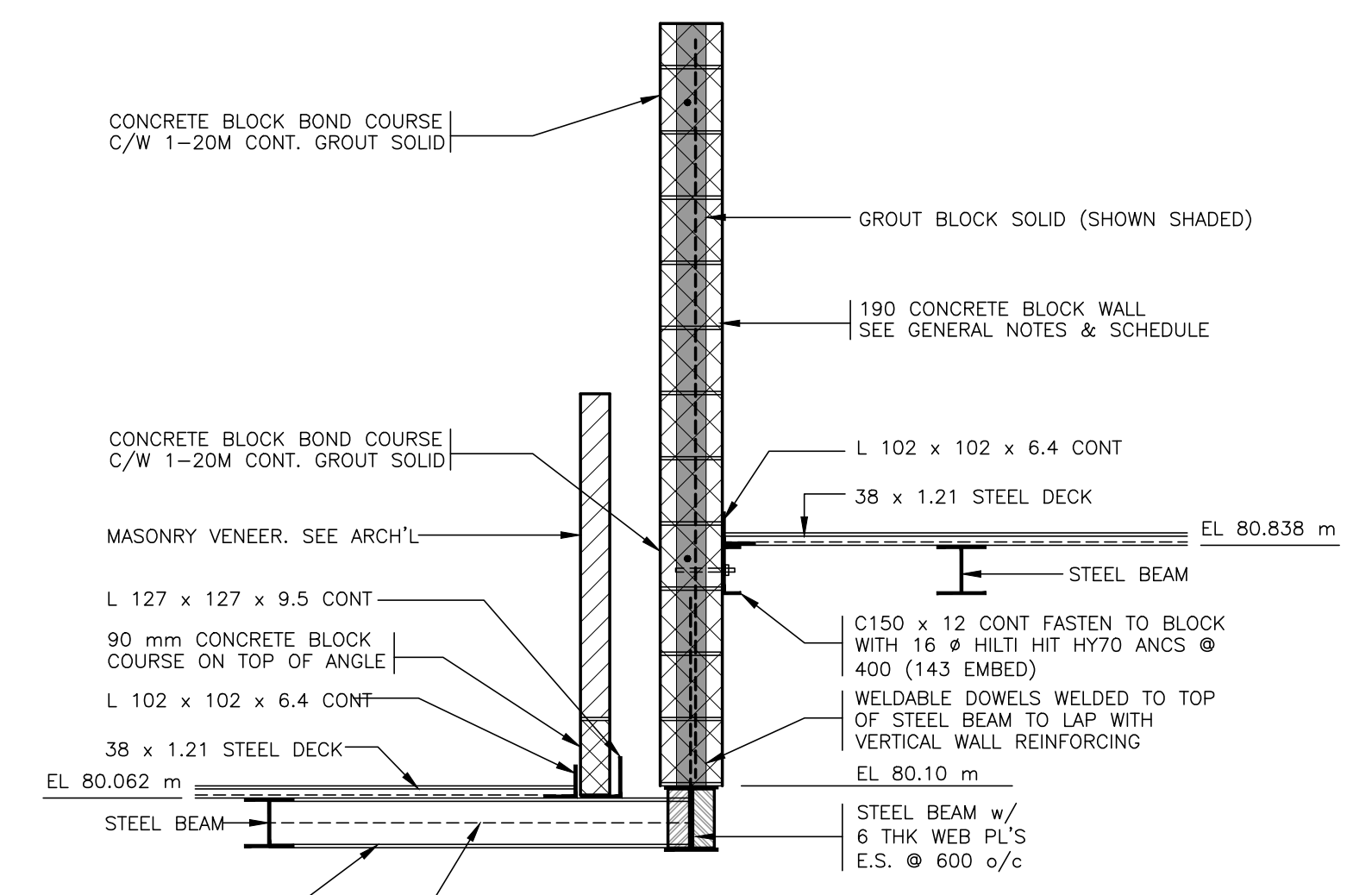

L5 SECTION
S103 1:20

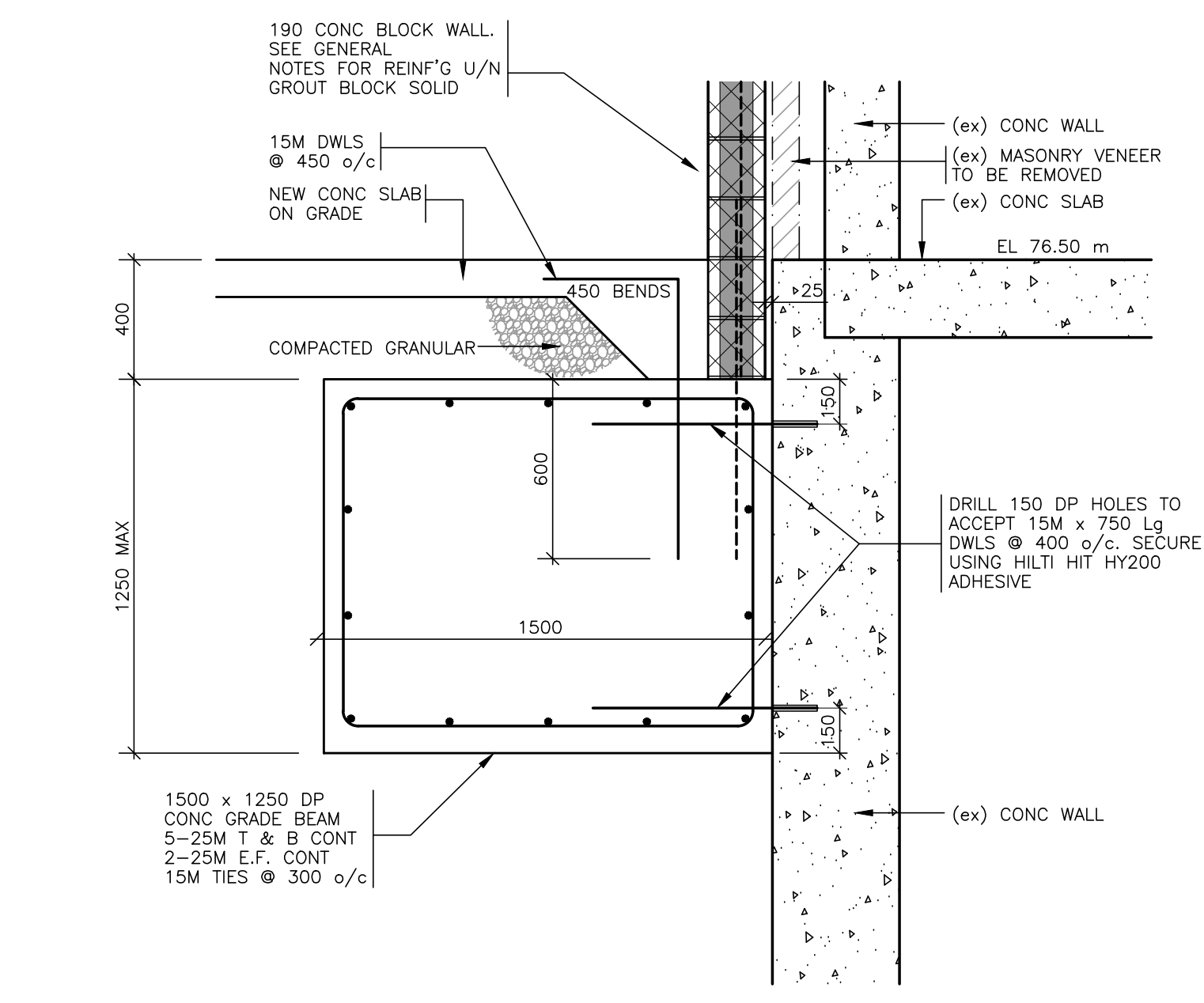

10 SECTION
S100 1:20

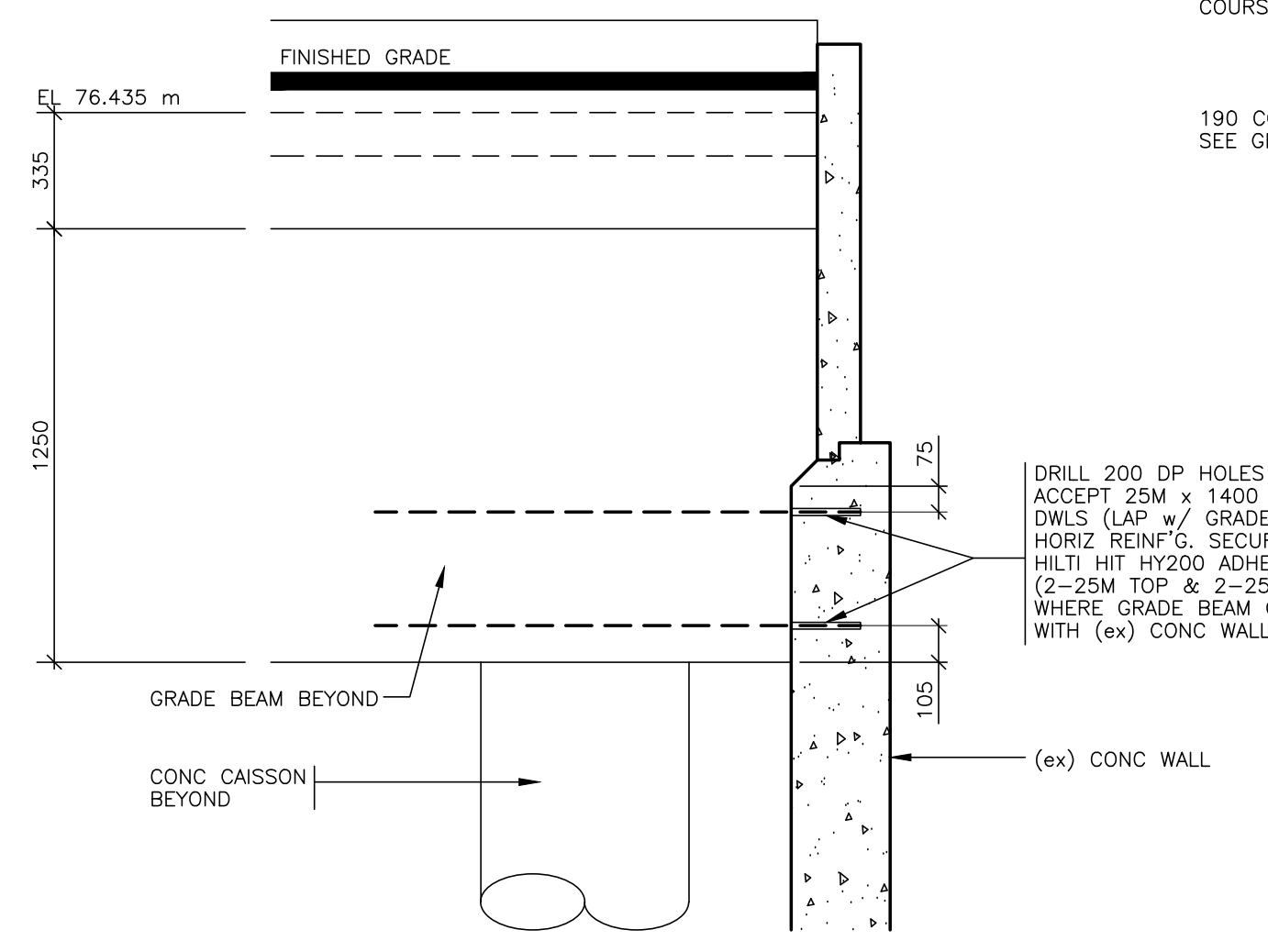

11 SECTION
S100 1:20

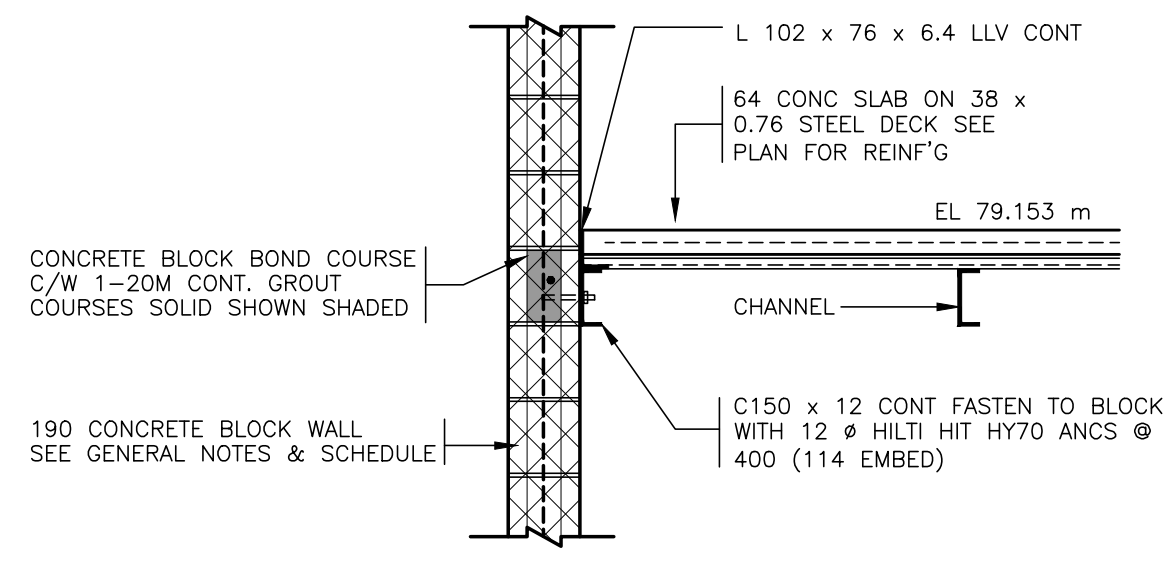

S3 SECTION
S102 1:20

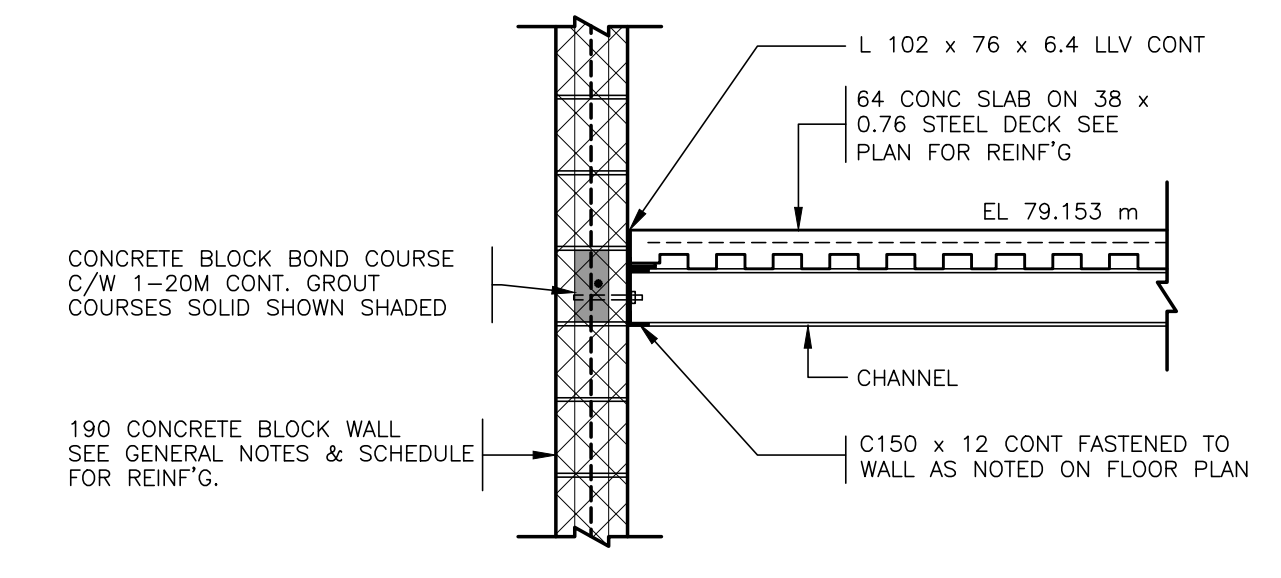

S4 SECTION
S102 1:20

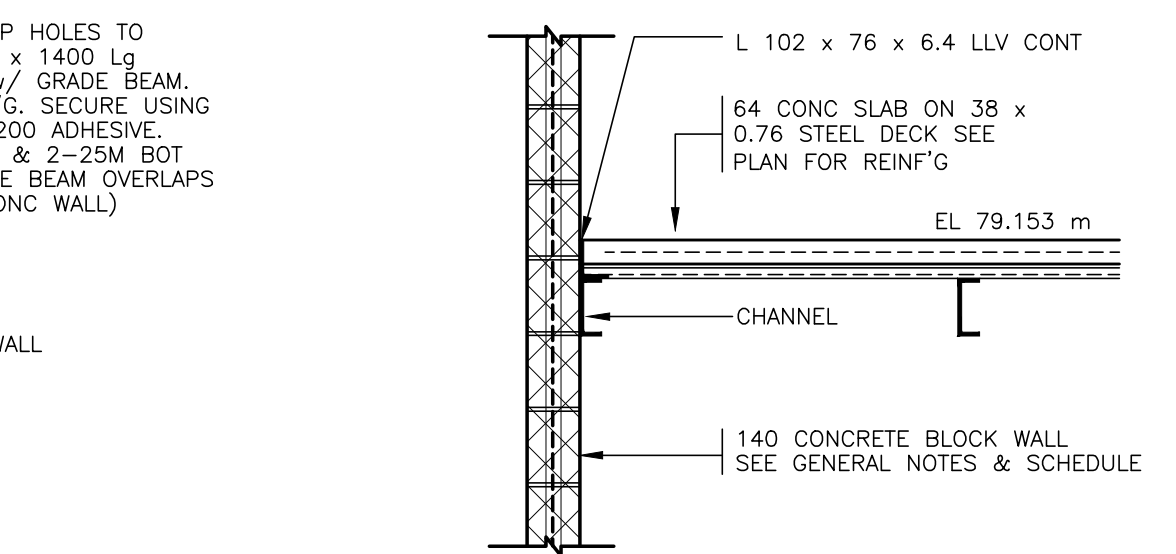

S1 SECTION
S102 1:20

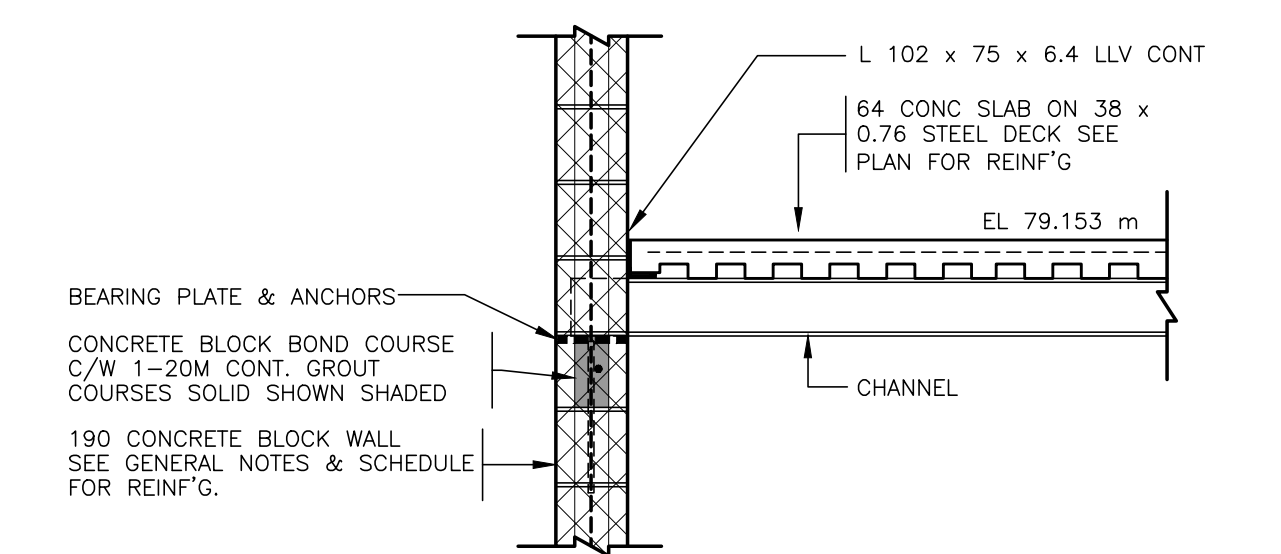

S2 SECTION
S102 1:20



6			
5			
4			
3	ISSUED FOR CONSTRUCTION	2017/09/29	RW
2	ISSUED FOR BUILDING PERMIT	2017/07/25	RW
1	ISSUED FOR INFORMATION	2017/06/23	RW
NUMBER	MILESTONE / FMT SAILLANT	DATE	(Y/M/D) (A/M/J)
DESIGNED BY / CONÇU PAR	JC	CHECKED BY / VÉRIFIÉ PAR	JC
DRAWN BY / DÉSSINÉ PAR	RW	SCALE / ÉCHELLE	1:50

DETAIL NUMBER	
DRAWING TITLE	SECTIONS & DETAILS
SCALE	1:20
SHEET NUMBER	11

THIS DRAWING IS THE PROPERTY OF THE CITY OF OTTAWA AND ALL COPYRIGHT IS RESERVED. DIMENSIONS ON DRAWING ARE FOR ESTIMATING PURPOSES ONLY. IT IS THE RESPONSIBILITY OF EACH CONTRACTOR AND SUB-CONTRACTOR OR CONSULTANT TO CHECK AND VERIFY ALL DIMENSIONS AND CONDITIONS ON SITE. NOTIFY OWNER OF ANY ERRORS OR OMISSIONS PRIOR TO COMMENCING THE WORK. DO NOT SCALE THE DRAWINGS.

CE DESSIN CONSTITUE LA PROPRIÉTÉ DE LA VILLE D'OTTAWA ET TOUT DROIT D'AUTEUR EST RÉSERVÉ. LES DIMENSIONS UTILISÉES SE SONT À DES FINS DESTINATION SEULEMENT. IL INCOMBE À CHAQUE ENTREPRENEUR, SOUS-CONTRACTANT OU CONSULTANT DE VÉRIFIER TOUTES LES DIMENSIONS ET LES CONDITIONS SUR LE CHANTIER. VEUILLEZ INFORMER LE PROPRIÉTAIRE DE TOUTE ERREUR OU OMISSION AVANT D'ENTAMER LES TRAVAUX. NE DRESSEZ PAS LES PLANS À L'ÉCHELLE.

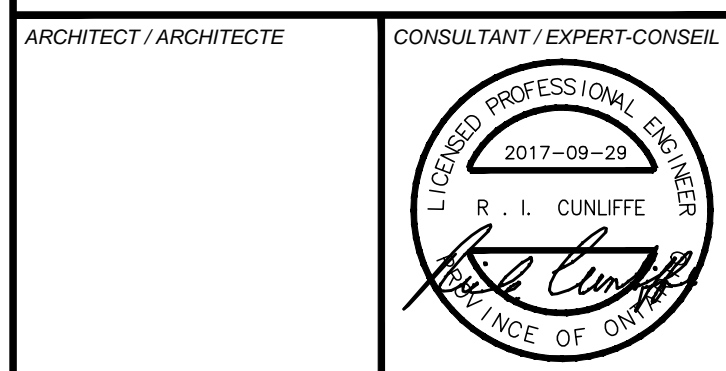

ARCHITECT / ARCHITECTE	CONSULTANT / EXPERT-CONSEIL

PROJECT / LOCATION / PROJET / ENDROIT

DOVERCOURT
PHASE 2
ADDITION & RENOVATION

411 DOVERCOURT
OTTAWA, ONTARIO

DRAWING / DESSIN
SECTIONS & DETAILS

FACILITY NO. / NO. DE INSTALLATIONS SHEET NO. / FEUILLE No.

S301

PROJECT NO. / PROJET No.
1713



6			
5			
4			
3	ISSUED FOR CONSTRUCTION	2017/09/29	RW
2	ISSUED FOR BUILDING PERMIT	2017/07/25	RW
1	ISSUED FOR INFORMATION	2017/06/23	RW
NUMBER / NUMÉRO	DATE / DATE	(Y/M/D) (A/M/J)	INITIALS INITIALES

DESIGNED BY / CONÇU PAR	JC	CHECKED BY / VÉRIFIÉ PAR	JC
DRAWN BY / DÉSSINÉ PAR	RW	SCALE / ÉCHELLE	1:50

DETAIL NUMBER 1	DRAWING TITLE
SHEET NUMBER	

THIS DRAWING IS THE PROPERTY OF THE CITY OF OTTAWA AND ALL COPYRIGHT IS RESERVED. DIMENSIONS ON DRAWING ARE FOR ESTIMATING PURPOSES ONLY. IT IS THE RESPONSIBILITY OF EACH CONTRACTOR AND SUB-CONTRACTOR OR CONSULTANT TO CHECK AND VERIFY ALL DIMENSIONS AND CONDITIONS ON SITE. NOTIFY OWNER OF ANY ERRORS OR OMISSIONS PRIOR TO COMMENCING THE WORK. DO NOT SCALE THE DRAWINGS.

CE DESSIN CONSTITUE LA PROPRIÉTÉ DE LA VILLE D'OTTAWA ET TOUT DROIT D'AUTEUR EST RÉSERVÉ. LES DIMENSIONS UTILISÉES SE SONT À DES FINS DESTINATION SEULEMENT. IL INCOMBE À CHAQUE ENTREPRENEUR, SOUS-CONTRACTANT OU CONSULTANT DE VÉRIFIER TOUTES LES DIMENSIONS ET LES CONDITIONS SUR LE CHANTIER. VEUILLEZ INFORMER LE PROPRIÉTAIRE DE TOUTE ERREUR OU OMISSION AVANT D'ENTAMER LES TRAVAUX. NE DRESSÉZ PAS LES PLANS À L'ÉCHELLE.

ARCHITECT / ARCHITECTE

CONSULTANT / EXPERT-CONSEIL

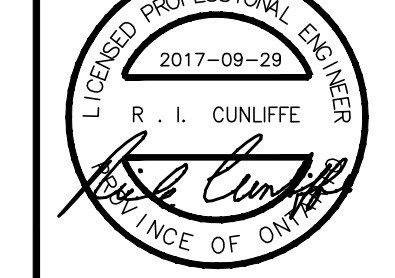

CONSULTANT / EXPERT-CONSEIL

CONSULTANT / EXPERT-CONSEIL

PROJECT / LOCATION / PROJET / ENDROIT

DOVERCOURT
PHASE 2
ADDITION & RENOVATION

411 DOVERCOURT
OTTAWA, ONTARIO

DRAWING / DESSIN
SECTIONS & DETAILS

FACILITY NO. / NO. DE INSTALLATIONS

SHEET NO. / FEUILLE NO.

S302

PROJECT NO. / PROJET NO.
1713

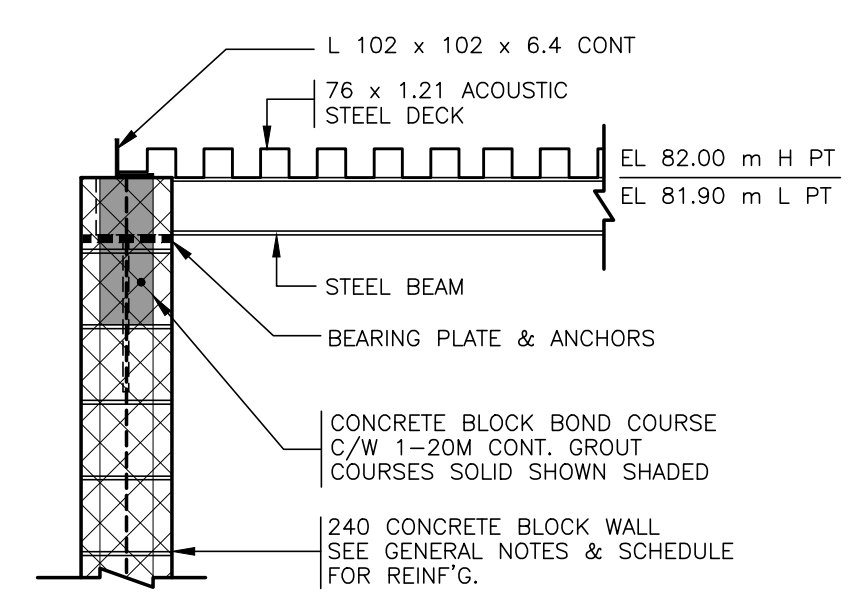

R9 SECTION
S104 1 : 20

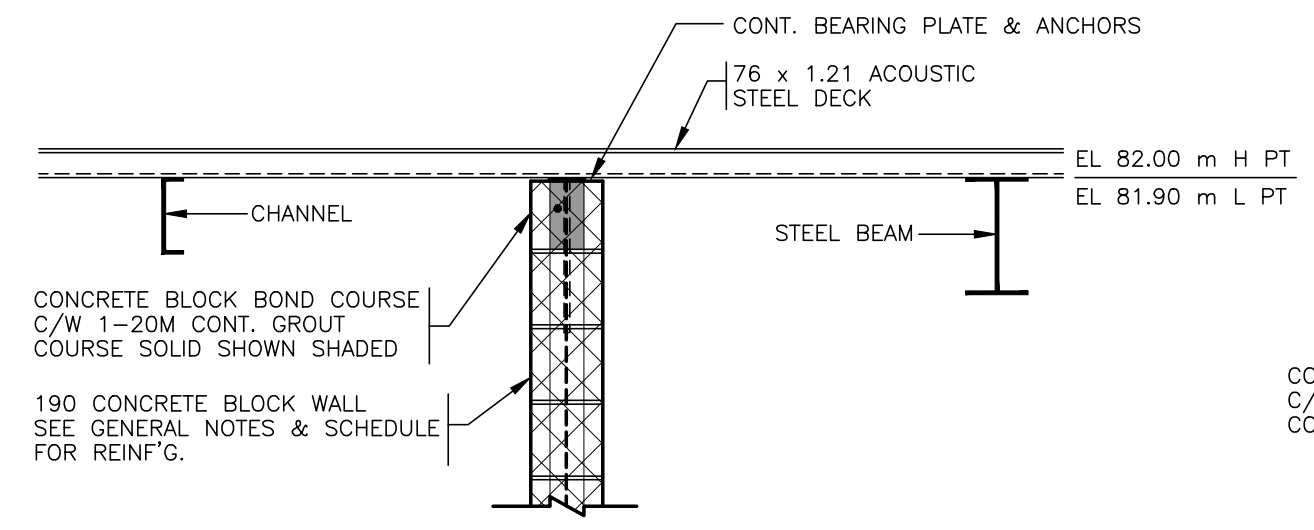

R10 SECTION
S104 1 : 20

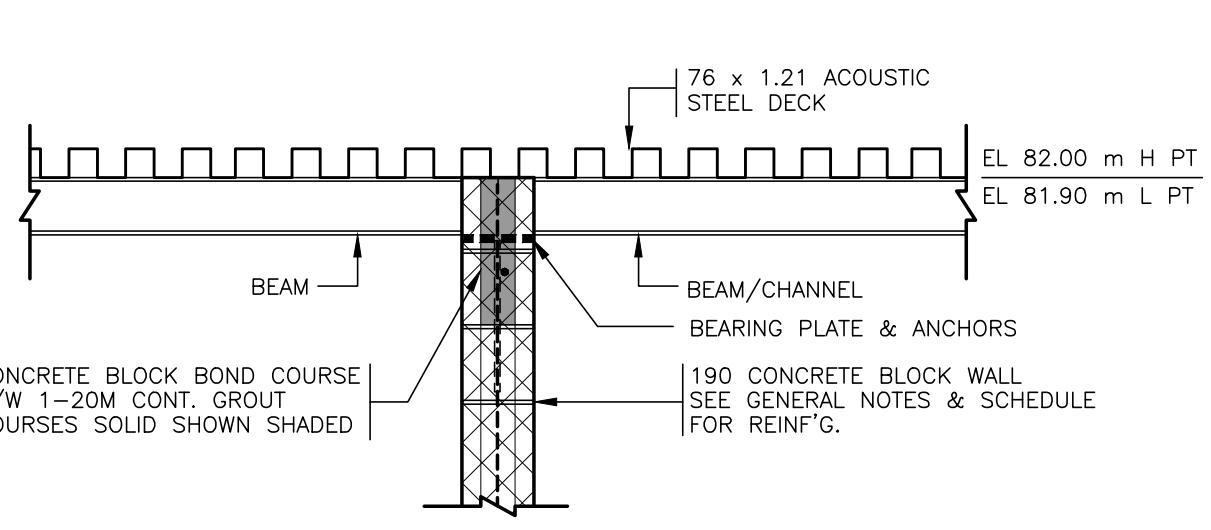

R11 SECTION
S104 1 : 20

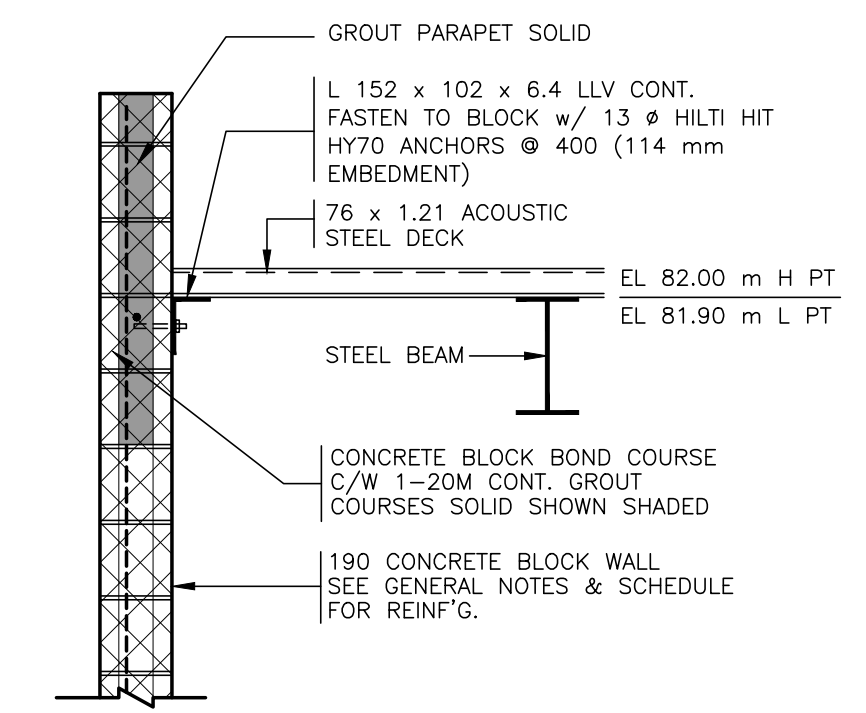

R3 SECTION
S104 1 : 20

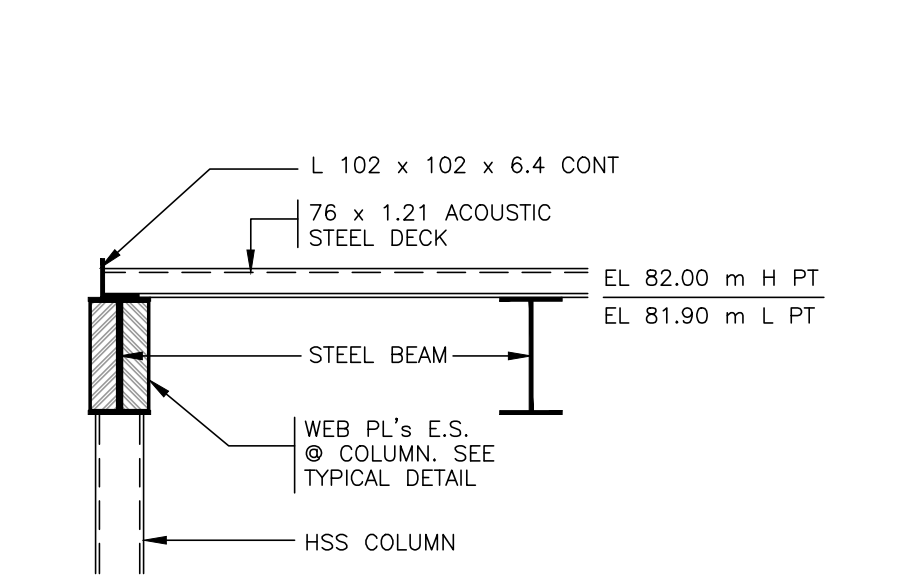

R4 SECTION
S104 1 : 20

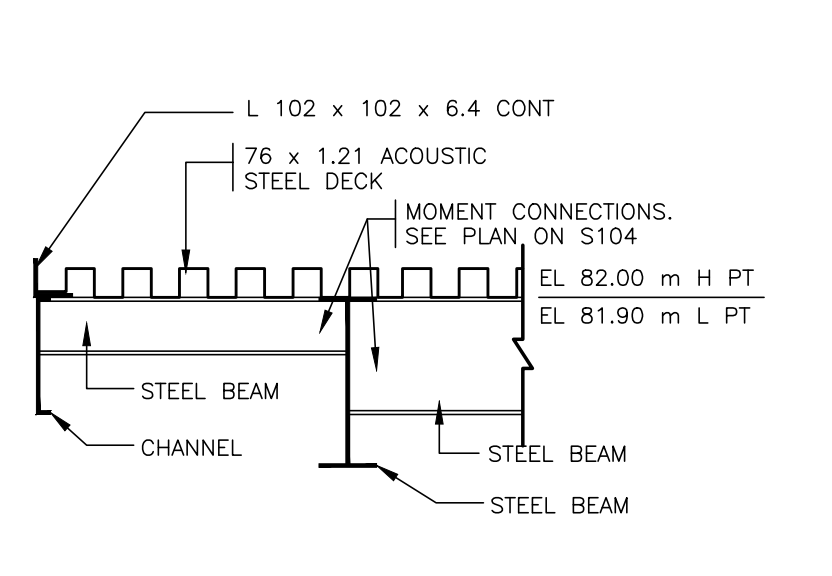

R5 SECTION
S104 1 : 20

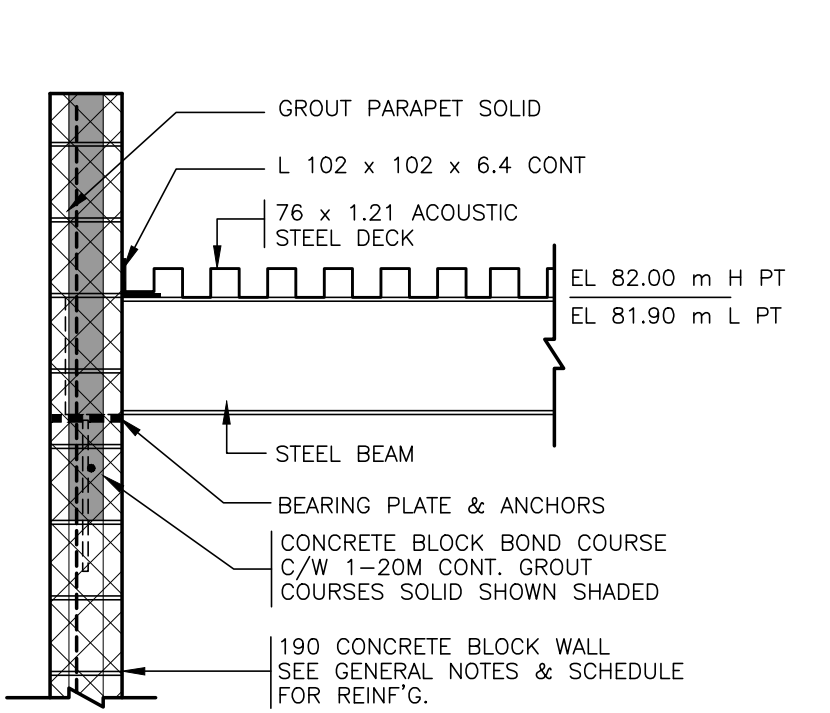

R6 SECTION
S104 1 : 20

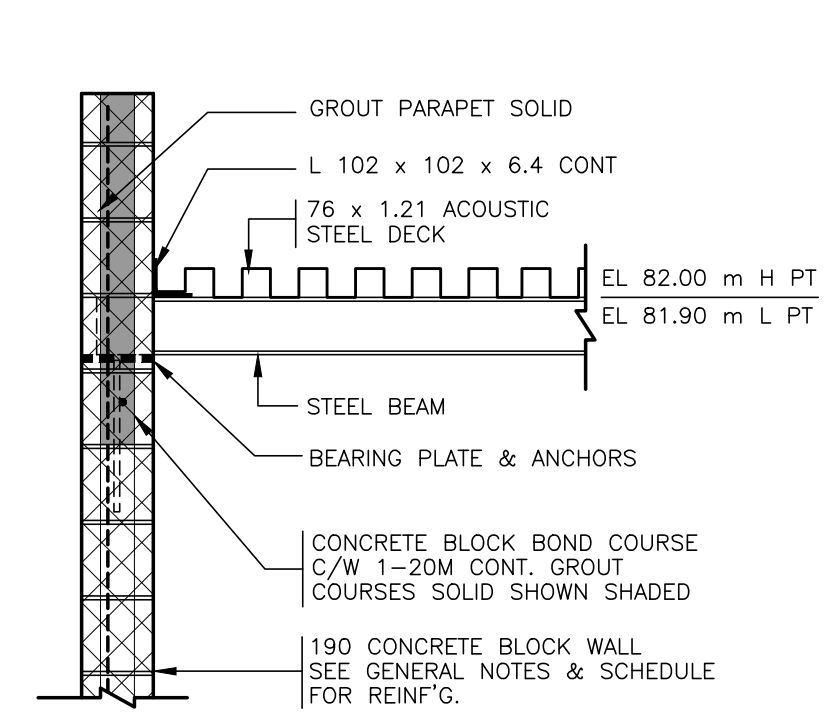

R7 SECTION
S104 1 : 20

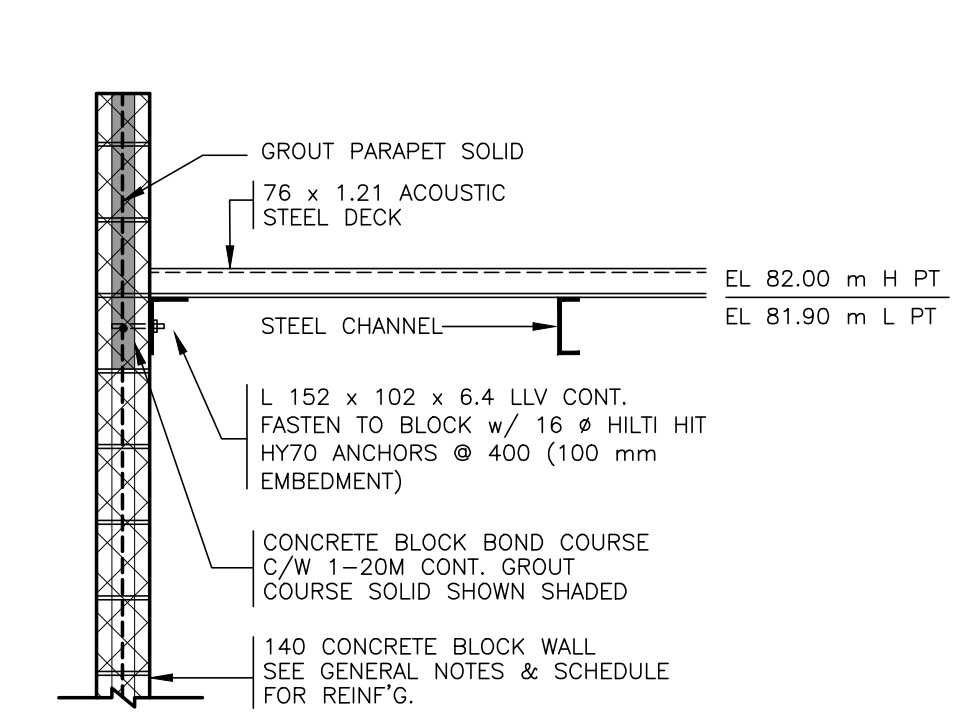

R8 SECTION
S104 1 : 20

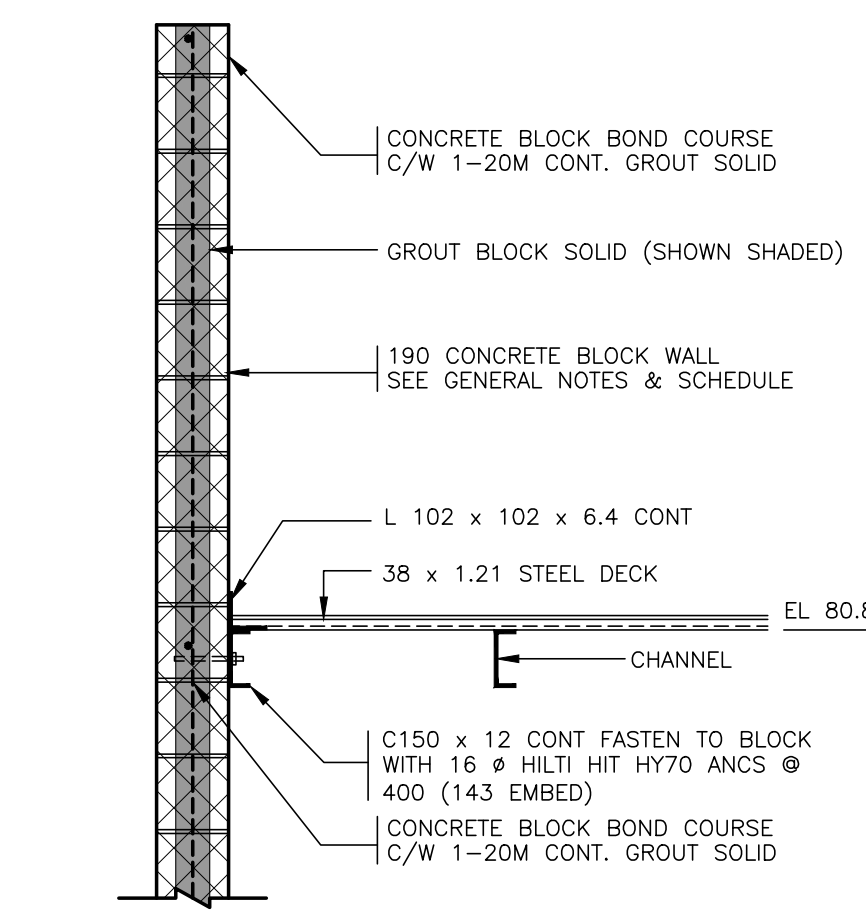

L12 SECTION
S103 1 : 20

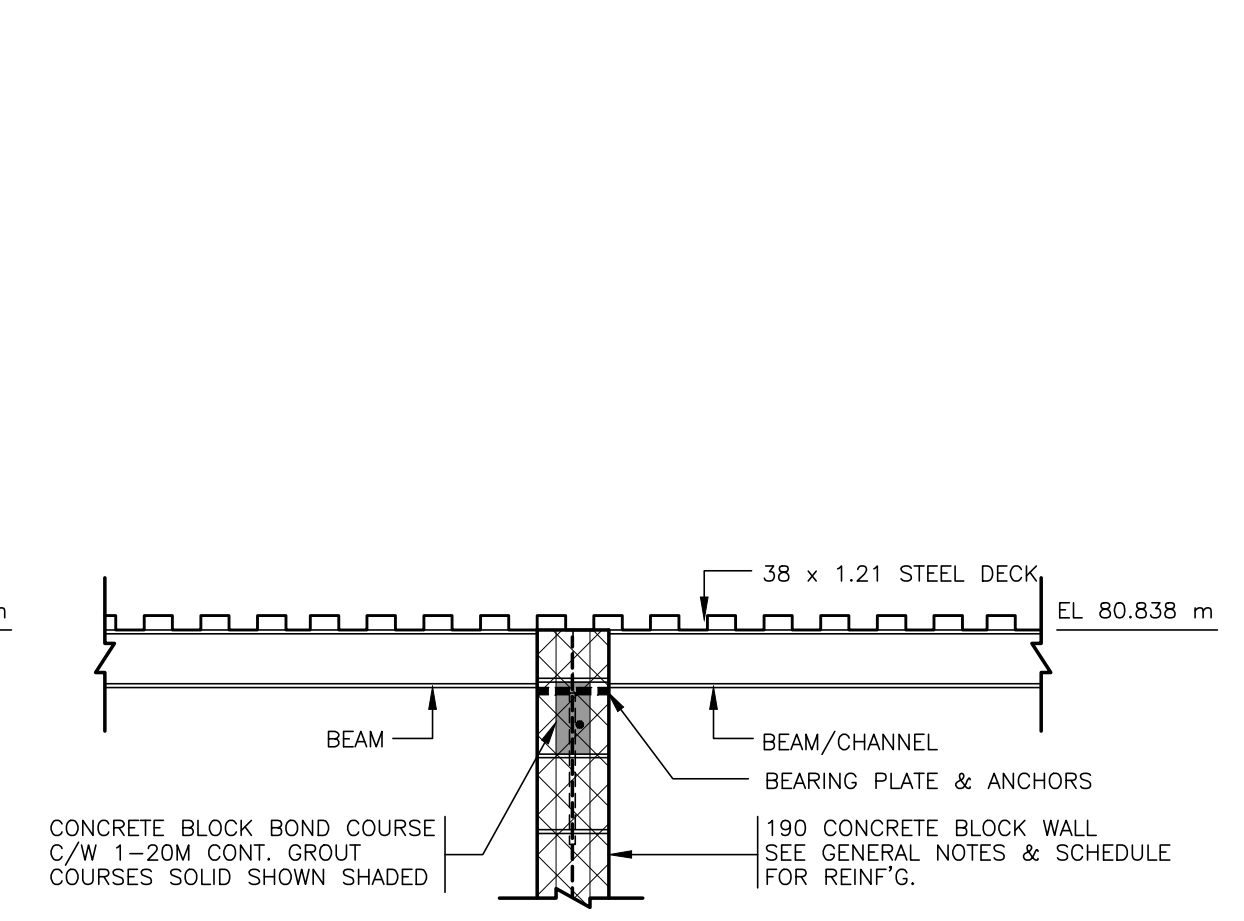

L13 SECTION
S103 1 : 20

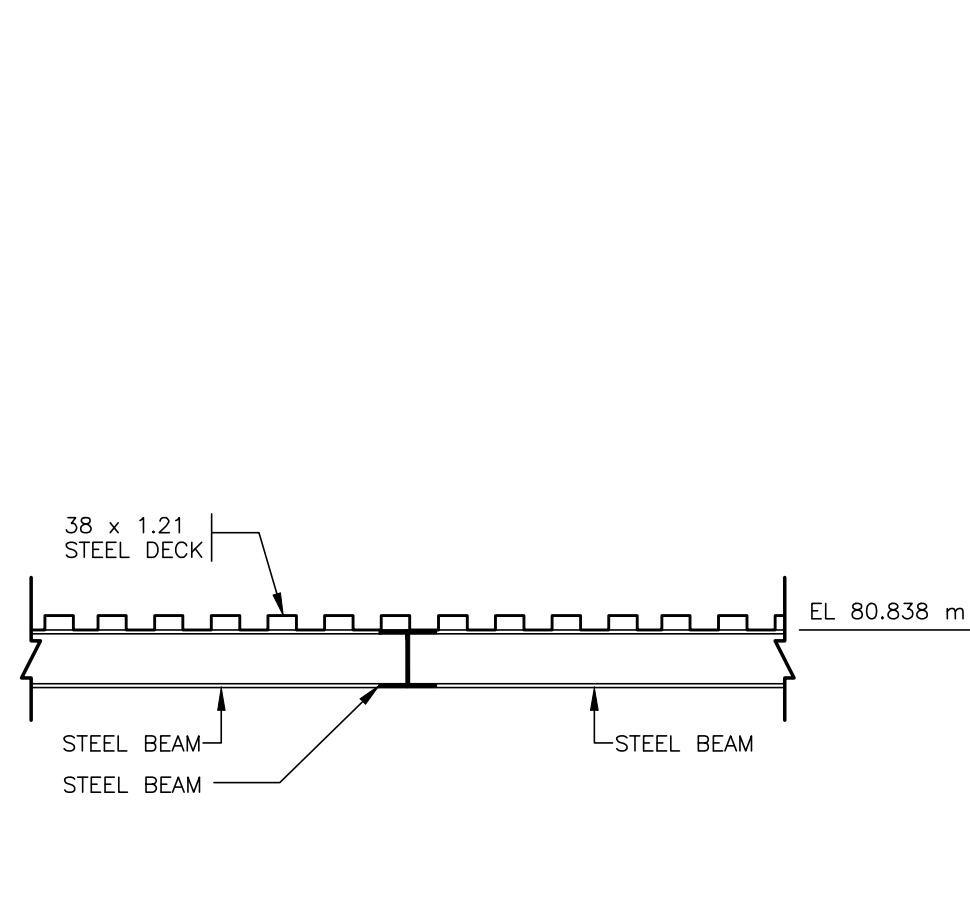

L14 SECTION
S103 1 : 20

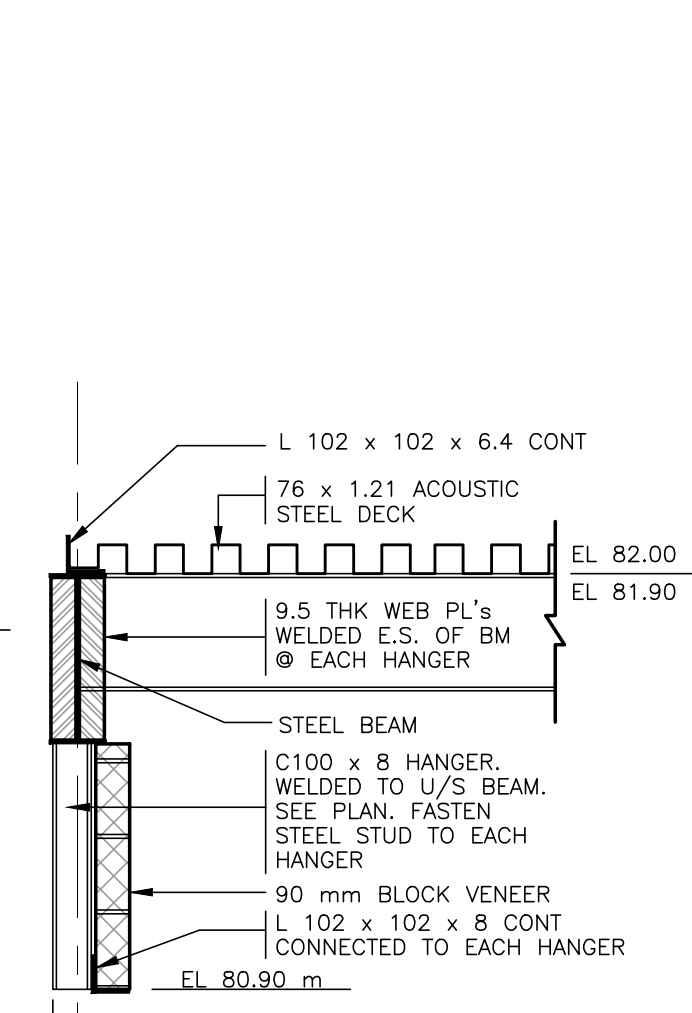

R1 SECTION
S104 1 : 20

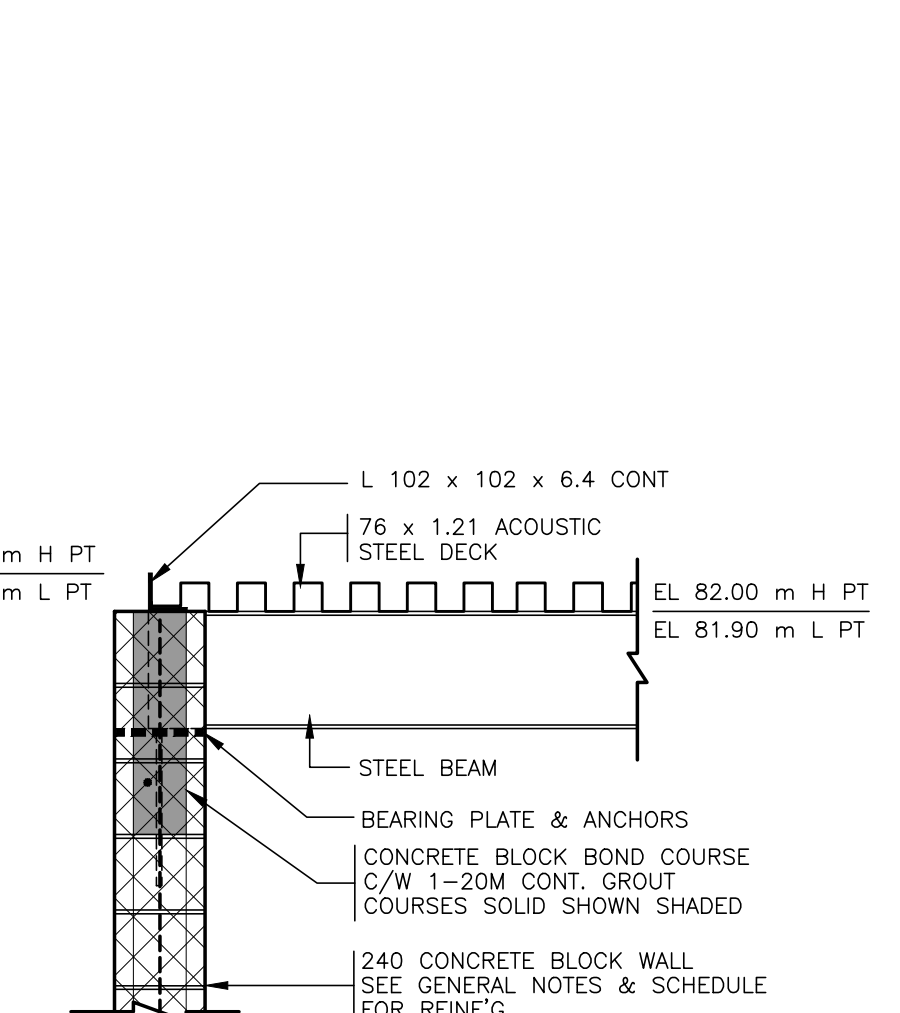

R2 SECTION
S104 1 : 20

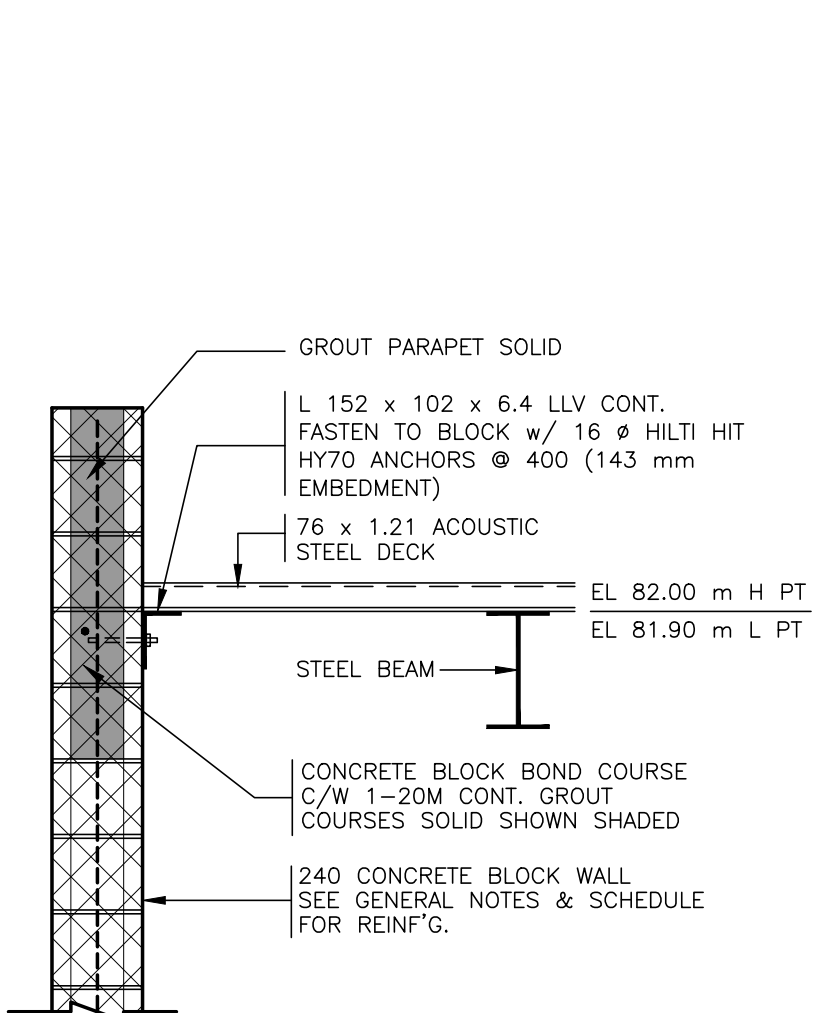

R2A SECTION
S104 1 : 20