

April 19, 2019

**ClaimsPro File No: #: 31110-039814 SRR**

Sent via email only

**TO:** All Firms

**RE:** Ottawa-Carleton Standard Condo Corp. No. 934  
Invitation to Tender – Community Building Reconstruction

---

Dear Contractors,

With reference to the above noted invitation to tender, please acknowledge the following as **Addendum Number 8**. This addendum forms part of the official Bid Documents and the costs shall form part of your Bid price. The purpose of this addendum is to provide Questions 25 through 32 and their answers (and also includes the attached “JeldWen Technical Bulletin and Specifications” package).

**Question 1:**

Specification section 05-50-00 part 2.17.2 refers to shelf angles cast into edge of floor slabs to support brick veneer cladding. Where are these angles located?

**Answer 1:**

The reference to cast in shelf angles is part of the base Section 05 50 00 specification and was not edited out - there should be no cast in shelf angles required on this project.

**Question 2:**

Mechanical Drawings show DW1 and W1 but there is no mention of these in any of the Schedules. Are we to assume these appliances are merely on the drawings for reference and supplied by owner?

**Answer 2:**

The insurance company will provide an allowance directly to the condominium corporation for the replacement and installation of the appliances. The mechanical and electrical drawings show the standard connections for residential appliances so connections are provided by the contractor.

**Question 3:**

Will consideration be given for an alternate proposal for an ADEX EIFS system in lieu of the specified Dryvit system?

**Answer 3:**

An ADEX EIFS system can be considered provided it meets the requirements noted in "Part 1 General" of Section 07 24 00:

Dryvit PD / NC EIFS System is the standard of acceptance only and alternatives proposed must meet or exceed the properties of the base system. Alternate systems will be considered only on the basis they very clearly demonstrate similarity to the specified Dryvit system and conformance to the “Pro Demnity” exclusion published September 16, 2009 and CCMC approvals and testing before acceptance. Manufacturers of alternate EIFS systems are responsible for clearly demonstrating

compliance with all subsections of this specification section. The work of this section describes a system which is to be single source / single responsibility.

**Question 4:**

Who will be responsible for the removal of all the existing temporary tarping, insulation and related framework within the footprint of the new building?

**Answer 4:**

The contractor who is awarded the project will be responsible for the removal and disposal of the temporary tarps, framing, and insulation, along with any and all associated costs.

**Question 5:**

Will we be allowed to hook up a distro panel for temporary power to the existing building's power supply?

**Answer 5:**

The contractor who is awarded the project will be able to connect a distribution panel for temporary power to the existing building's power supply provided the power usage does not interfere with the north and south tower unit owners and does not cause breaker interference. However, it is recommended that the contractor have a generator on standby for potential issues. It will be the responsibility of the contractor to provide compensation to the Condominium Corporation for their increased cost of electrical consumption.

**Question 6:**

Will we be able to tie into the existing DCW supply for use during construction?

**Answer 6:**

The contractor who is awarded the project will be allowed to use the building's water supply. It will be the responsibility of the contractor to provide compensation to the Condominium Corporation for its increased cost of water consumption.

**Question 7:**

Please provide Specifications for the Granite Hearth and Surround at the fireplace.

**Answer 7:**

Allow for 19mm thick Cambrian Black granite.

**Question 8:**

What would be the earliest start date for the project?

**Answer 8:**

The contractor who is awarded the project is expected to start any pre-work and order all materials for the earliest possible start in accordance with the Proposed Project Start Date. The project must still be completed before the Proposed Project Elapse Time.

**Question 9:**

There is a note on the Electrical Drawings to provide a separate unit price to replace all the exit signs in the existing apartment building. Please provide specifications and quantities.

**Answer 9:**

We are awaiting reply from the architect. However, additional costs for upgrades and/or change orders to replace all the exit signs beyond those damaged by this fire will be costed separately and is the responsibility of the Condominium Corporation beyond their insurance claim. The contractor is responsible to obtain written authorization from the condominium corporation prior to undertaking this work.

**Question 10:**

The instruction to tenders references the owners timeline and liquidated damages that are tied to milestones. I didn't see a schedule of milestones in the new project documents, did I overlook them or would we be able to get them.

**Answer 10:**

The milestones include all project activities and interim steps needed to implement the project. The proposed schedule and gantt chart is to be provided by the contractor and is to be included in the Bid package. Milestones are required for the planning, development, construction phases, evaluation, reporting of substantial completion, and turnover to the property owner. The milestone dates are projected dates which commence with the tender award.

**Question 11:**

The answer for question 10 didn't really give any new information, the owner seems to have a fast track timeline they would like to meet as per the excerpt below from the instruction to tenders. To accurately price the work we will need to know when we need to have it substantially complete by so if the schedule we propose doesn't match up with the owners and our bid is scored lower because of it.

"The work will have an aggressive schedule to meet the Owner's timelines"

**Answer 11:**

This project has an proposed timeline of +/- 8 months from the date the Condominium Corporation signs a contract/authorization with the contractor. The Condominium Corporation requires the Contractor to provide a gantt chart so the Condominium Corporation can monitor the progress of the project and provide updates to the residents.

**Question 12:**

Has a building permit been received.

**Answer 12:**

A building permit has been received and is attached as Appendix A to this package.

**Question 13:**

Better clarity is required as to whether or not the parking garage is to be used during the repairs.

**Answer 13:**

It was always the intention that the parking garage be available to the unit owners if so authorized by the AHJ. It was also recognized there was no guarantee the AHJ would allow full or partial use of the parking garage and they could, in their sole discretion, even rescind any permission they may grant.

Article 27.2.5 of the Instructions to Bidders will be replaced with the following:

"All reasonable efforts are to be made to obtain all necessary approvals to allow for use of the residential parking garage throughout the duration of the project. The contractor shall seek approval from the Authorities Having Jurisdiction ("AHJ") to ensure continued use of the parking garage. If approved by the AHJ, and after each owner, tenant and board member have signed a waiver releasing the contractor from all liability resulting from damages and injury to body or property during construction, the parking garage will remain open with the following additional terms:

- a) No access is to be granted for owner, tenant or contractor use until the proper approval and documentation is received from AHJ for the project;
- b) Contractor will remain responsible for the security and accessibility of all zoned areas of the property, identified and demarcated as "Construction" areas during the reconstruction phase of the development;
- c) Once the Contractor has secured approval for residential access and use of the parking garage, it shall secure the overhead parking garage entrance from all potential falling objects. Contractor **must** also notify the

board members and post notification signs up with enough notice of intent, when the underground parking area would not be accessible for residential parking during construction. **Any such garage closure to be the minimum possible duration in all of the circumstances;**

d) Execution of the waiver by the owners, tenants and Board Members does not remove the obligation of the contractor to act reasonably and with the care and skill required;

e) Notwithstanding the foregoing, the AHJ has the sole discretion to allow either ongoing or intermittent use of the parking garage. The AHJ has the right, at any time and without warning, to suspend or terminate use of the parking garage.”

**Question 14:**

Please provide Division 32 Specifications.

**Answer 14:**

The landscaping specifications are attached as Appendix B to this package.

**Question 15:**

Are we able to access the East side of the elevated landscaped area via a temporary access road from either Tallwood Drive or Chrysalis Way? If so, should an allowance be carried for reinstatement of any softscape for said access road?

**Answer 15:**

If a contractor requires access to the East side of the elevated landscaped area, the Condominium Corporation agrees to such access. However, the contractor agrees to undertake and be directly responsible for all logistics, tasks, and costs associated with this access such as, but not necessarily limited to:

- Obtaining all necessary permits from Authorities Having Jurisdiction;
- Obtaining utility locates;
- Verifying existence of underground sprinkler pipes, water and sewer services;
- Verifying existence of above ground utilities;
- Obtaining written permission from adjacent property owners as necessary;
- Construction, maintenance, and removal of the temporary access road;
- Traffic control, signage, safety fencing;
- Reinstatement of all areas affected by the temporary access road;
- Repair of all damages to property of the Condominium Corporation and others

**Question16:**

Do we know which company did the original landscaping? If so, please forward their contact info.

**Answer 16:**

The original landscape contractor is identified as:

Davis Landscape and Design  
14 Grenfell Crescent  
Nepean, ON  
613-225-5656

**Question 17:**

There is a Roof Access Ladder to access the RTU but is there an Attic Access required as well? If so, please provide Details and Specs as well as the location.

**Answer 17:**

A standard residential type 550mm x 900mm attic access panel is to be provided in the ceiling of Stor-1 (Room 113).

**Question 18:**

Is there a Grease Interceptor required for the Kitchen? If so, please provide Details and Specs as well as the location.

**Answer 18:**

No requirement for a grease interceptor has been identified - all of the appliances in the kitchen will be standard residential units and the kitchen is only intended to be used for residential type cooking, as was the case with the original building.

**Question 19:**

Additional details are required regarding the movable partition doors and how they attach.

**Answer 19:**

The additional details related to the movable partition doors and how they attach at the end of the pocket are attached as Appendix C to this package.

**Question 20:**

Can we get a detail on how is the junction between the existing membrane behind masonry to remain (BVE and STE) below the new masonry (BVN) as shown on elevation 1/A3.1

**Answer 20:**

There is an existing precast band and a section of existing brick between that precast and the stone band below that are called up as new masonry on the elevation. When the existing masonry is removed we are anticipating that the new membrane can be lapped over the existing one but this will need to be verified once the masonry is removed.

**Question 21:**

Would it be possible to get more information on the concrete block back-up for the 2 columns at the West Elevation, a plan detail and detailing of the taper. The assembly on A2.02 seems a little different than typical.

**Answer 21:**

The concrete block backup on drawing A2.02 is shown as it would be at the very top of the tapered pier. Alternate backup block layouts can be considered once a masonry contractor is selected.

**Question 22:**

Is there any repairs or tie in details required to the existing masonry to remain at both links.

**Answer 22:**

There are a couple of bricks on one pier on the courtyard side that could be replaced using salvaged brick if available. Other than this the masonry at the links should only require cleaning.

**Question 23:**

Is there any chance you can give us a few more days, even if just till Thursday of that week it is closing?

**Answer 23:**

It is agreed the bid submission date and time will be changed to Thursday, April 25, 2019, 2:00pm.

**Question 24:**

One of our EIFS Contractors has requested an ADEX system to be used as an alternate system to the Dryvit system on the above mentioned project. Please see their formal proposal below and attached. Apparently this system has been approved on a few of Hobin's other projects.

**Answer 24:**

See the attached Package "Adex Information" along with the following:

The ADEX-RS EIFS system, as described in the submitted materials, is acceptable as an approved alternate to the specified Dryvit Outsulation PD assembly subject to the following requirements:

1. Applicator will meet the qualification requirements noted in item 1.5.2, under Quality Assurance, of the Adex-RS System Specification.
2. Applicator to provide a letter from Adex certifying that the applicator is an Adex approved applicator, knowledgeable in the proper installation of the Adex-RS System and provide confirmation that the personnel to be involved in the installation of the system have passed the required training available from Adex for this specific system.

**Question 25:**

Would I be able to get Jeld-Wens Sitaline aluminum clad windows approved as an alternate to the Lepage that is specified? Please find attached the details and performance data.

**Answer 25:**

Jeld-Wen is acceptable as an alternate window manufacturer subject to confirmation by the energy modelling consultant that the selected windows meet the energy efficiency standard required by the energy model. We refer to the attached Technical Bulletin and Specifications.

**Question 26:**

In the Scope of Reconstruction, Part F.2 states the following:

"Upgrades on mechanicals to facilitate the design changes of the center building will be a factor and costs overrun from original design will be costed separately for the account of the owners."

Are we expected to provide pricing as per the original design for comparison? Please clarify the expectations of how this should be presented. There isn't a line item for this on the Bid Form similar to Landscaping.

**Answer 26:**

The replacement building has very minor interior changes which do not appear to have impacted the mechanical systems. Because of this, there is no additional "upgrade" cost which the Condominium Corporation would be responsible for beyond their insurance coverage. Pricing is to be provided based upon the reconstruction drawings prepared by Hobin Architecture.

**Question 27:**

Landscape Specifications reference an Irrigation System. There isn't anything mentioned on the Mechanical Drawings. Is there an existing Irrigation system?

**Answer 27:**

- Yes, there was an existing irrigation system. The main control panels was destroyed in the fire as well as a number of the irrigation heads and hoses near the central part of the building;
- The contractor is responsible for visiting the site to determine the extent of the damage to the irrigation system in order to provide an accurate price for repair (or replacement);
- The overall system was winterized;
- For the upper level: A new controller is required within the community building, and distribution irrigation piping is anticipated to the 1st or 2nd irrigation head, and an unspecified number of damaged irrigation heads are required;
- For the lower level: the controller is within the garage and is not affected. The distribution irrigation piping to the lower level irrigation heads is intact but an unspecified number of irrigation heads are required at the front of the building;

- The plumbing trade would be responsible for provision of new supply piping to the controller. The irrigation trade then is responsible for the controller and its connection, and following work related to distribution irrigation piping and irrigation heads.
- Hobin Architecture is to provide additional response to confirm if the non-freeze hose bib connection shown in Storage Room 3 was intended to be the connection point.

**Question 28:**

Specifications for the Precast Concrete Unit Paving show the size for Type 1 and Type 2 Pavers to be 150mm X 150mm. These Pavers comes in varying sizes, full pallets are NOT available in the specified size listed. Please advise if it is acceptable to provide Pavers in the 3 different sizes on each pallet.

**Answer 28:**

Yes, the mixed paver size as supplied on each pallet is acceptable (min paver size 150 x 130mm – max paver size 150 x 188mm).

**Question 29:**

The instruction to bidders mentions carrying bonding, I don't see the amount of Labour & Material and Performance bonding that we should carry, 50/50 or 100/100.

**Answer 29:**

The existence of bonding is an important component of the bidding process. In an effort to provide flexibility to the contractors, the insurer does not specify the amount of bonding to be carried for a project of this size. The contractors should carry bonding which they feel is appropriate given the size of this project, the capability of the contractor, and the best practices of the contractor.

**Question 30:**

The breakout of pricing on the tender form will be near impossible to acquire at time of closing. Contractors and subcontractors don't price the items listed in that breakdown individually. The easiest way to get this information is using the Master Format Divisions of work. (Div. 0-50) If the breakdown is used for insurance purposes it would be best to clarify with the low bidder.

**Answer 30:**

We ask for a detailed breakdown in an attempt to ensure accuracy in the overall bid process. This is to try to detect mistakes that could either result in bidders accidentally forgetting to bid a section of work or accidentally overbid a section of work. It will allow the consultant to contact the bidders if need be for specific discussion prior to making a recommendation.

**Question 31:**

The note under Div 29a-c is confusing, as I understand we are to price the landscaping on the tender form provided in the addendum. On the breakdown it says "*Contractors to specify only the increased or decreased price from original base*" and also "*Price to be kept separate to the main bid but included in the bid package*" which leads me to believe you want a number in the box on page 3 but are not to include it in the total tally on page 6. Some simplification and organization of the tender form would go a long way to help the Contractors pricing the work.

**Answer 31:**

The contractors are to price the value of the original landscaping and enter that value in Box 29A. The Condominium Corporation desires to upgrade the landscaping but may not move forward with the upgrades if the upgrade cost is too much. The contractors are to use Box 29C to indicate the increased or decreased cost of upgrading beyond the original design. The value indicated in Box 29C should not be included in the total value of the bid submission because it is for information purposes only to assist the Condominium Corporation with their decision as to whether or not they move ahead with upgrading the landscaping.

**Question 32:**

Updated contact information for the landscaper provided under Question 16 is now provided.

**Answer 32:**

Kristopher Cybanski, G.S.C.  
Commercial Estimator / Project Manager  
M. Davis Landscape and Design Inc.  
3000 Rushmore Road  
RR#2  
Richmond, ON K0A 2Z0  
613-838-8744 Ext 25  
613-838-5779 Fax  
[www.davislandscaping.com](http://www.davislandscaping.com)

You are requested to acknowledge receipt of Addendum Number 8 in your Bid.

ClaimsPro Inc.

A handwritten signature in blue ink that reads "Scott Rolofs". The signature is written in a cursive style with a large initial 'S'.

Scott Rolofs, CIP, CFEI(C)  
Senior General Adjuster  
[scott.rolofs@scm.ca](mailto:scott.rolofs@scm.ca)  
Direct: 613-443-1206

**Total Window Performance**

Total window performance measures the centre of glass, the largest area for heat gain and loss, as well as the edge of the glass and the window's frame to provide an overall U-factor, solar heat gain coefficient and condensation resistance rating.

**Note:** Information presented is based on 3mm glazing. Number may vary when other glass thicknesses and tinted glazings are used. Please consult your sales representative for more details. Data for grids < 25mm are based on grilles between glass. Data for grids ≥ 25mm are based on SDL's with shadow bars between glass. U-Factor<sup>1</sup>: Btu/h-ft<sup>2</sup>·F (imperial) U-Factor<sup>2</sup>: W/m<sup>2</sup>·K (metric).

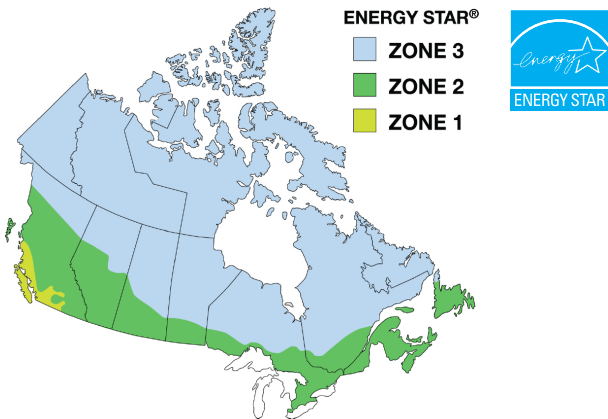

FEBRUARY 2015-DECEMBER 2015 QUALIFYING CRITERIA							
WINDOWS							
Zone	Heating Degree-Day Range	COMPLIANCE PATHS					
		Energy Rating (ER)	Max Air Leakage	or	U-Factor		Max Air Leakage
		Minimum ER (Dimensionless) Maximum U-Factor 2.00 W/m <sup>2</sup> ·K (0.35 Btu/h·ft <sup>2</sup> ·F)			Maximum U-Factor W/m <sup>2</sup> ·K (0.35 Btu/h·ft <sup>2</sup> ·F)	Minimum ER (Unitless)	
1	< 3500	25	1.5	or	1.60 (0.28)	16	1.5
2	≥ 3500 to < 6000	29	1.5	or	1.40 (0.25)	20	1.5
3	≥ 6000	34	1.5	or	1.20 (0.21)	24	1.5

For more information visit [www.nrcan.gc.ca](http://www.nrcan.gc.ca)

**Siteline Wood Collection**

Dual Glazed Low E		Dual Glazed 3MM																	
		Low E 180 Argon						Low E 272 Argon						Low E 366 Argon					
TYPE	GRILLES	U <sup>1</sup>	U <sup>2</sup>	SHGC	VT	ER	ESTAR ZONE 2015	U <sup>1</sup>	U <sup>2</sup>	SHGC	VT	ER	ESTAR ZONE 2015	U <sup>1</sup>	U <sup>2</sup>	SHGC	VT	ER	ESTAR ZONE 2015
Awning	Without	0.28	1.59	0.47	0.54	32	2	0.28	1.59	0.25	0.47	19	1	0.27	1.53	0.19	0.44	17	1
	With < 25mm	0.28	1.59	0.42	0.48	29	2	0.28	1.59	0.23	0.43	18	1	0.27	1.53	0.17	0.40	16	1
Casement	Without	0.28	1.59	0.47	0.54	32	2	0.28	1.59	0.25	0.47	19	1	0.27	1.53	0.19	0.44	17	1
	With < 25mm	0.28	1.59	0.42	0.48	29	2	0.28	1.59	0.23	0.43	18	1	0.27	1.53	0.17	0.40	16	1
Fixed	Without	0.28	1.59	0.51	0.58	34	3	0.27	1.53	0.27	0.52	22	1	0.26	1.48	0.20	0.48	19	1
	With < 25mm	0.28	1.59	0.45	0.52	31	2	0.27	1.53	0.25	0.46	21	1	0.26	1.48	0.18	0.42	18	1
Double Hung	Without	0.30	1.70	0.50	0.57	31	2	0.29	1.65	0.27	0.51	19	NO	0.29	1.65	0.20	0.47	15	NO
	With < 25mm	0.30	1.70	0.45	0.51	28	1	0.29	1.65	0.24	0.45	17	NO	0.29	1.65	0.18	0.42	13	NO
Double Hung Picture	Without	0.28	1.59	0.52	0.60	35	3	0.27	1.53	0.28	0.53	22	1	0.27	1.53	0.21	0.49	18	1
	With < 25mm	0.28	1.59	0.47	0.53	32	2	0.27	1.53	0.25	0.47	21	1	0.27	1.53	0.19	0.44	17	1
Double Hung Transom	Without	0.28	1.59	0.53	0.61	36	3	0.27	1.53	0.28	0.54	22	1	0.27	1.53	0.21	0.50	18	1
	With < 25mm	0.28	1.59	0.47	0.54	32	2	0.27	1.53	0.26	0.48	21	1	0.27	1.53	0.19	0.44	17	1
Direct Set	Without	0.28	1.59	0.59	0.69	39	3	0.27	1.53	0.32	0.61	25	1	0.26	1.48	0.24	0.56	21	1
	With < 25mm	-	-	-	-	-	-	-	-	-	-	-	-	-	-	-	-	-	-

U-Factor<sup>1</sup>: Btu/h-ft<sup>2</sup>·F (imperial)  
U-Factor<sup>2</sup>: W/m<sup>2</sup>·K (metric)

## Siteline Clad Wood Collection

Dual Glazed Low E		Dual Glazed 3MM																	
		Low E 180 Argon						Low E 272 Argon						Low E 366 Argon					
TYPE	GRILLES	U <sup>1</sup>	U <sup>2</sup>	SHGC	VT	ER	ESTAR ZONE 2015	U <sup>1</sup>	U <sup>2</sup>	SHGC	VT	ER	ESTAR ZONE 2015	U <sup>1</sup>	U <sup>2</sup>	SHGC	VT	ER	ESTAR ZONE 2015
Awning	Without	0.29	1.65	0.46	0.53	30	2	0.28	1.59	0.25	0.47	19	1	0.28	1.59	0.19	0.43	16	1
	With < 25mm	0.29	1.65	0.42	0.48	28	1	0.28	1.59	0.23	0.42	18	1	0.28	1.59	0.17	0.39	15	NO
Casement	Without	0.29	1.65	0.46	0.53	30	2	0.28	1.59	0.25	0.47	19	1	0.28	1.59	0.25	0.47	16	1
	With < 25mm	0.29	1.65	0.42	0.48	28	1	0.28	1.59	0.23	0.42	18	1	0.28	1.59	0.17	0.39	15	NO
Fixed	Without	0.28	1.59	0.54	0.62	36	3	0.27	1.53	0.29	0.55	23	1	0.27	1.53	0.22	0.51	19	1
	With < 25mm	0.28	1.59	0.49	0.55	33	2	0.27	1.53	0.26	0.49	21	1	0.27	1.53	0.20	0.45	18	1
Double Hung	Without	0.30	1.70	0.50	0.57	31	2	0.29	1.65	0.27	0.50	18	NO	0.29	1.65	0.20	0.47	14	NO
	With < 25mm	0.30	1.70	0.44	0.51	27	1	0.29	1.65	0.24	0.45	17	NO	0.29	1.65	0.18	0.41	13	NO
Double Hung Picture	Without	0.28	1.59	0.52	0.60	35	3	0.27	1.53	0.28	0.53	17	1	0.27	1.53	0.21	0.49	18	1
	With < 25mm	0.28	1.59	0.47	0.53	32	2	0.30	1.70	0.25	0.47	16	NO	0.27	1.53	0.19	0.43	17	1
Double Hung Transom	Without	0.29	1.65	0.53	0.60	34	3	0.28	1.59	0.29	0.54	22	1	0.28	1.59	0.21	0.49	17	1
	With < 25mm	0.29	1.65	0.47	0.54	31	2	0.28	1.59	0.26	0.48	20	1	0.28	1.59	0.19	0.44	16	1
Direct Set	Without	0.28	1.59	0.60	0.69	40	3	0.27	1.53	0.32	0.61	25	1	0.26	1.48	0.24	0.56	21	1
	With < 25mm	0.28	1.59	0.54	0.62	36	3	0.27	1.53	0.29	0.55	23	1	0.26	1.48	0.22	0.50	20	1

U-Factor<sup>1</sup>: Btu/h-ft<sup>2</sup>·F (imperial)  
U-Factor<sup>2</sup>: W/m<sup>2</sup>·K (metric)

Triple Glazed Low E (1 coat)		Triple Glazed 3MM																	
		1 x Low E 180 Argon						1 x Low E 272 Argon						1 x Low E 366 Argon					
TYPE	GRILLES	U <sup>1</sup>	U <sup>2</sup>	SHGC	VT	ER	ESTAR ZONE 2015	U <sup>1</sup>	U <sup>2</sup>	SHGC	VT	ER	ESTAR ZONE 2015	U <sup>1</sup>	U <sup>2</sup>	SHGC	VT	ER	ESTAR ZONE 2015
Casement	Without	-	-	-	-	-	-	0.22	1.25	0.23	0.43	26	2	-	-	-	-	-	-
	With < 25mm	-	-	-	-	-	-	0.22	1.25	0.21	0.39	25	2	-	-	-	-	-	-
Direct Set	Without	-	-	-	-	-	-	0.21	1.19	0.30	0.56	31	2	-	-	-	-	-	-
	With < 25mm	-	-	-	-	-	-	0.21	1.19	0.27	0.50	29	2	-	-	-	-	-	-

U-Factor<sup>1</sup>: Btu/h-ft<sup>2</sup>·F (imperial)  
U-Factor<sup>2</sup>: W/m<sup>2</sup>·K (metric)

Triple Glazed Low E (2 coats)		Triple Glazed 3MM																	
		2 x Low E 180 Argon						2 x Low E 272 Argon						2 x Low E 366 Argon					
TYPE	GRILLES	U <sup>1</sup>	U <sup>2</sup>	SHGC	VT	ER	ESTAR ZONE 2015	U <sup>1</sup>	U <sup>2</sup>	SHGC	VT	ER	ESTAR ZONE 2015	U <sup>1</sup>	U <sup>2</sup>	SHGC	VT	ER	ESTAR ZONE 2015
Casement	Without	0.18	1.02	0.38	0.47	39	3	-	-	-	-	-	-	-	-	-	-	-	-
	With < 25mm	0.18	1.02	0.35	0.42	38	3	-	-	-	-	-	-	-	-	-	-	-	-
Direct Set	Without	0.16	0.91	0.49	0.61	48	3	-	-	-	-	-	-	-	-	-	-	-	-
	With < 25mm	0.16	0.91	0.44	0.54	45	3	-	-	-	-	-	-	-	-	-	-	-	-

U-Factor<sup>1</sup>: Btu/h-ft<sup>2</sup>·F (imperial)  
U-Factor<sup>2</sup>: W/m<sup>2</sup>·K (metric)

**Note:** Information presented is based on 3mm glazing. Number may vary when other glass thicknesses and tinted glazings are used. Please consult your sales representative for more details. Data for grids < 25mm are based on grilles between glass. Data for grids ≥ 25mm are based on SDLs with shadow bars between glass.



TABLE OF CONTENTS

---

**Product Information**

General Information.....2  
 Lite Cut Information.....3  
 Handling & Operation.....4  
 Unit Sizing, Rough Opening & Masonry Openings.....5

**Options**

Trim.....6  
 Glass Stop.....7  
 Jamb Extender.....8  
 Mullion:  
     Standard.....9  
     Spread.....10  
 Divided Lite.....12

**Sizing Details**

Min-Max Sizing:  
     Operator.....14  
     Picture.....15

**Sections Details**

Operating:  
     Vertical Section.....16  
     Horizontal Section.....17  
     Impact - Vertical Section.....18  
     Impact - Horizontal Section.....19  
 Fixed:  
     Vertical Section.....20  
     Horizontal Section.....21  
     Impact - Vertical Section.....22  
     Impact - Horizontal Section.....23  
 Pushout:  
     Vertical Section.....24  
     Horizontal Section.....25  
 Pushout Fixed:  
     Vertical Section.....26  
     Horizontal Section.....27  
 Radius Top - Vertical Section.....28  
 Direct Set Segment Head - Vertical Section.....29  
 Bay & Bow - Vertical Section.....30  
 Bay:  
     30° - Horizontal Section.....31  
     45° - Horizontal Section.....32  
 Bow:  
     3 Wide - Horizontal Section.....33  
     4 Wide - Horizontal Section.....34  
     5 Wide - Horizontal Section.....35  
     6 Wide - Horizontal Section.....36



GENERAL INFORMATION

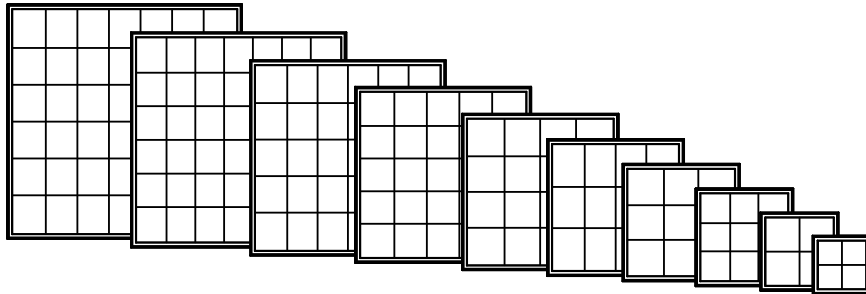

**Dimensional Windows**

Siteline clad casement windows may be specified as "dimensional", by adjusting the desired rough opening width or height.

Siteline clad casement windows are available with left or right hand operation, or stationary (non-venting). Operating mechanism includes corrosion resistant steel hinges and dual arm roto-type operator with hardened steel gears and operating arms. Sash locks are concealed unison type with an exposed locking lever and escutcheon plate. There are several interior hardware finish options. Refer to the Specifications for finish options.

**Multiple Assemblies**

Siteline clad casement windows may be mullered above, below, or beside other clad casement windows, or other clad window products.

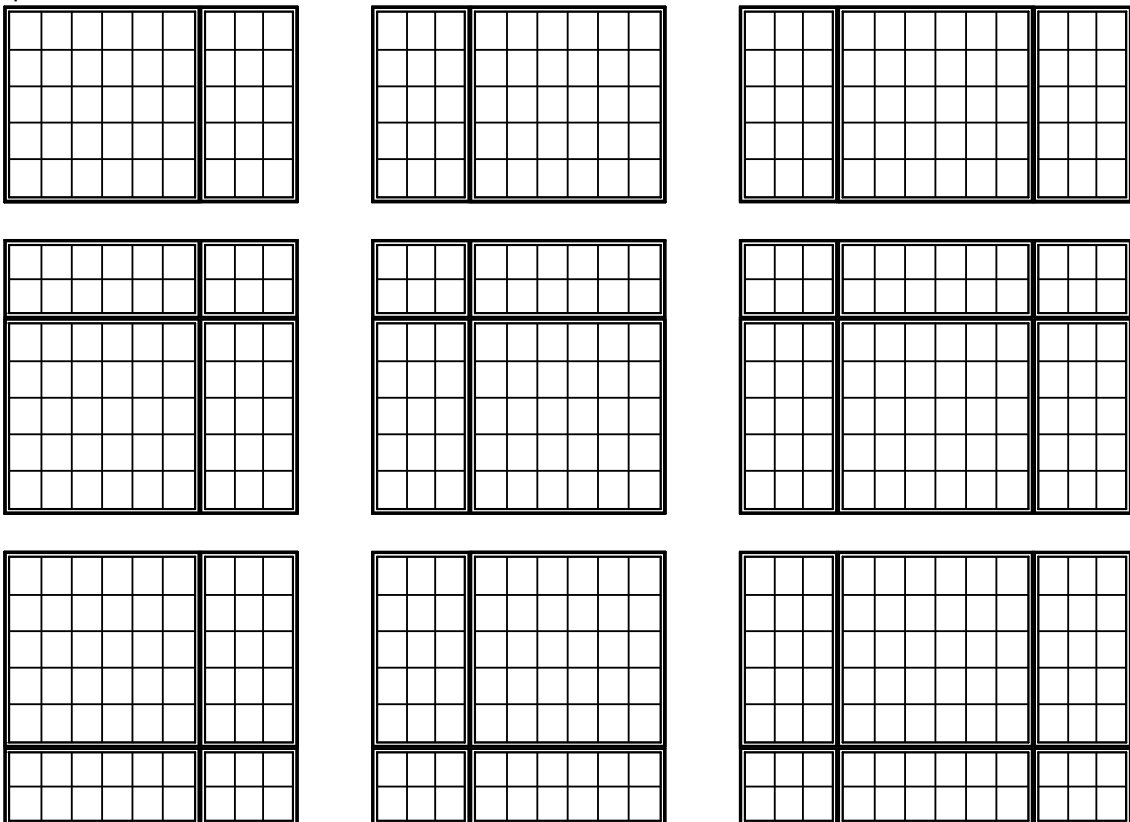



LITE CUT INFORMATION

Siteline clad casement windows are available with removable grilles in 7/8", 1-1/8" and 1-3/8" widths, Airspace (between the panes) grilles, and Simulated Divided Lites. Standard lite cuts are rectangular, and conform to the layouts noted in the charts on the next page. To use the chart, refer to the appropriate table by the type of window and type of bars or grilles the section drawings illustrate. Then simply cross reference the frame Height and Width to determine the standard lite cut.

Lite Cut Options

Special lite cut patterns can include a wide variety of straight line and radius patterns. The illustrations shown here represent just a few of the possibilities. Rectangular, horizontal, vertical and Prairie lite patterns are available in all standard size clad casement windows. Uneven, diamond, radius and Gothic lite cuts are available, subject to approval. Approvals are based on the ability to fulfill the design requirement while maintaining the construction integrity of the finished product.

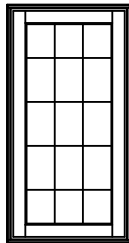

Rectangular

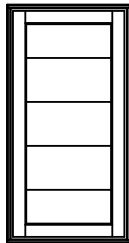

Horizontal

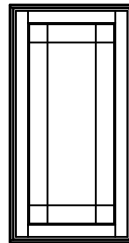

Prairie

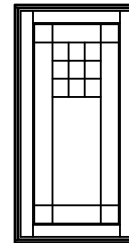

Uneven

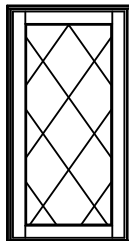

Diamond

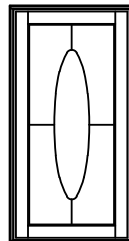

Radius

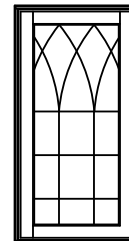

Gothic

Bar Alignment

Alignment of divided lite muntin bars from one window to the next is often required by fine architectural design. Wood grilles, Grilles Between the Glass, grilles, and Simulated Divided Lites may be specified with muntin bars aligned.

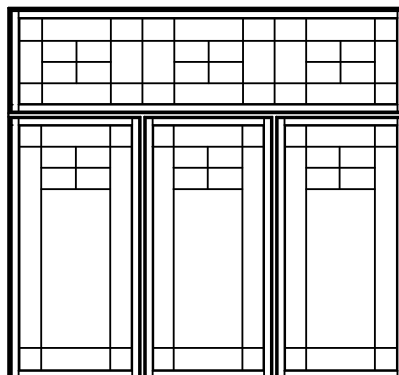



HANDING & OPERATION

---

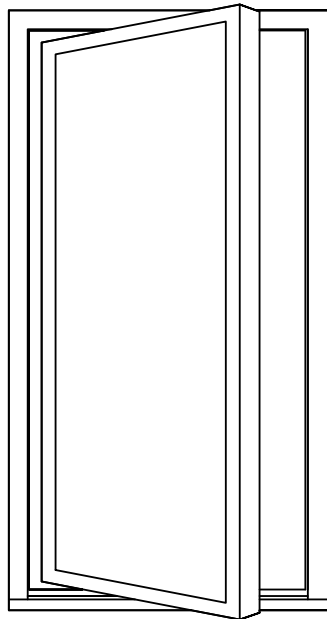

Left  
Hand

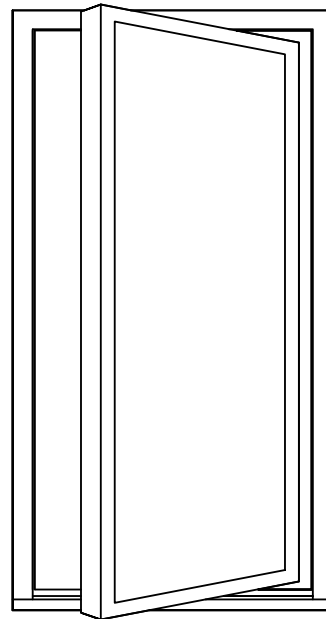

Right  
Hand

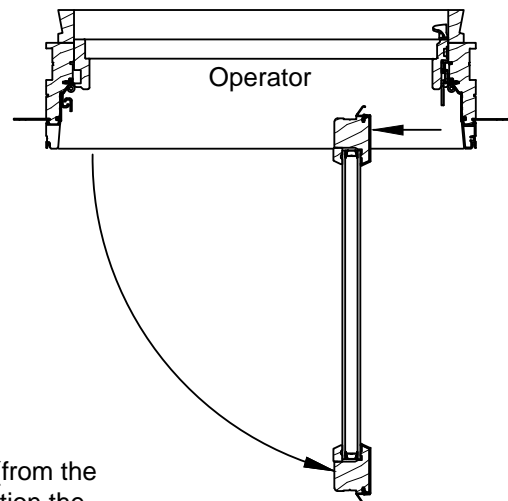
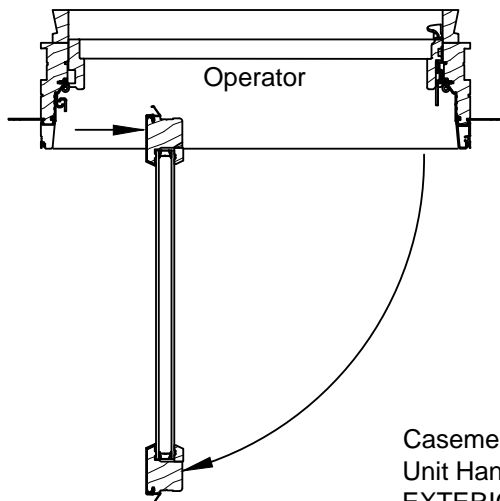

Casement Unit Handing:  
Unit Handing is defined (from the  
EXTERIOR) as the direction the  
sash opens.



**UNIT SIZING, ROUGH OPENING & MASONRY OPENINGS**

**General Notes:**

Unit size is always the maximum size of the window with or without trim and does not include nail fin.

**Masonry Opening:**

Masonry opening is always 1/2" over (height and width) the unit size or the outside of the trim of the window.

**Rough Opening:**

Rough opening is always 3/4" over frame size of the window.

Horizontal exterior trim offerings below are the same with or without sill nose.

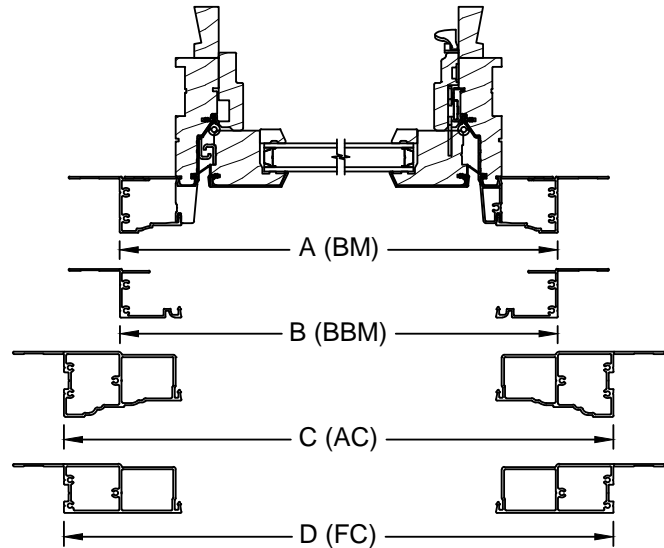

Horizontal Sections		
Trim Option	Dimension	Frame +
Brickmould (BM)	A	3"
Beaded Brickmould (BBM)	B	3"
Adams Casing (AC)	C	6"
3 1/2" Flat Casing (FC)	D	6"

Vertical exterior trim offerings without sill nose. Trim on all 4 sides.

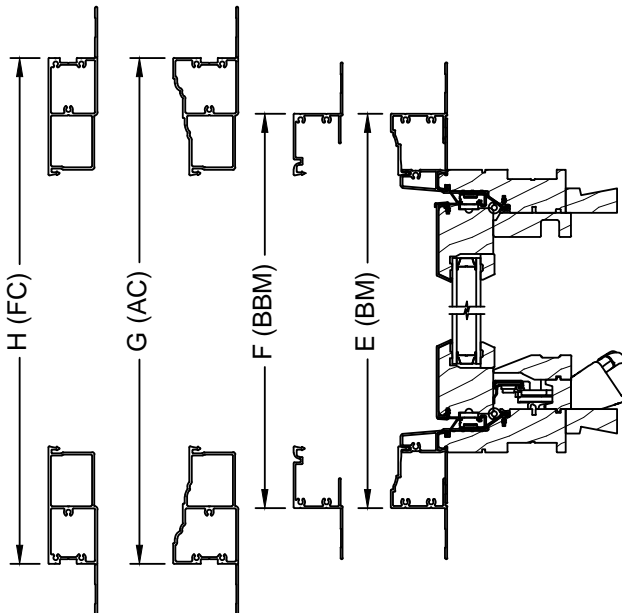

Vertical Sections (w/o Sill Nose)		
Trim Option	Dimension	Frame +
Brickmould (BM)	E	3"
Beaded Brickmould (BBM)	F	3"
Adams Casing (AC)	G	6"
3 1/2" Flat Casing (FC)	H	6"

Vertical exterior trim offerings with standard sill nosing. Trim on 3 sides.

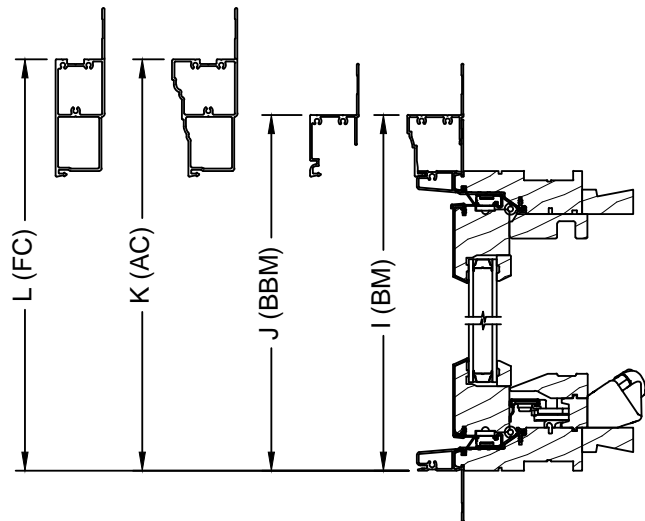

Vertical Sections (w/ Sill Nose)		
Trim Option	Dimension	Frame +
Brickmould (BM)	I	1-13/16"
Beaded Brickmould (BBM)	J	1-13/16"
Adams Casing (AC)	K	3-5/16"
3 1/2" Flat Casing (FC)	L	3-5/16"



TRIM OPTIONS

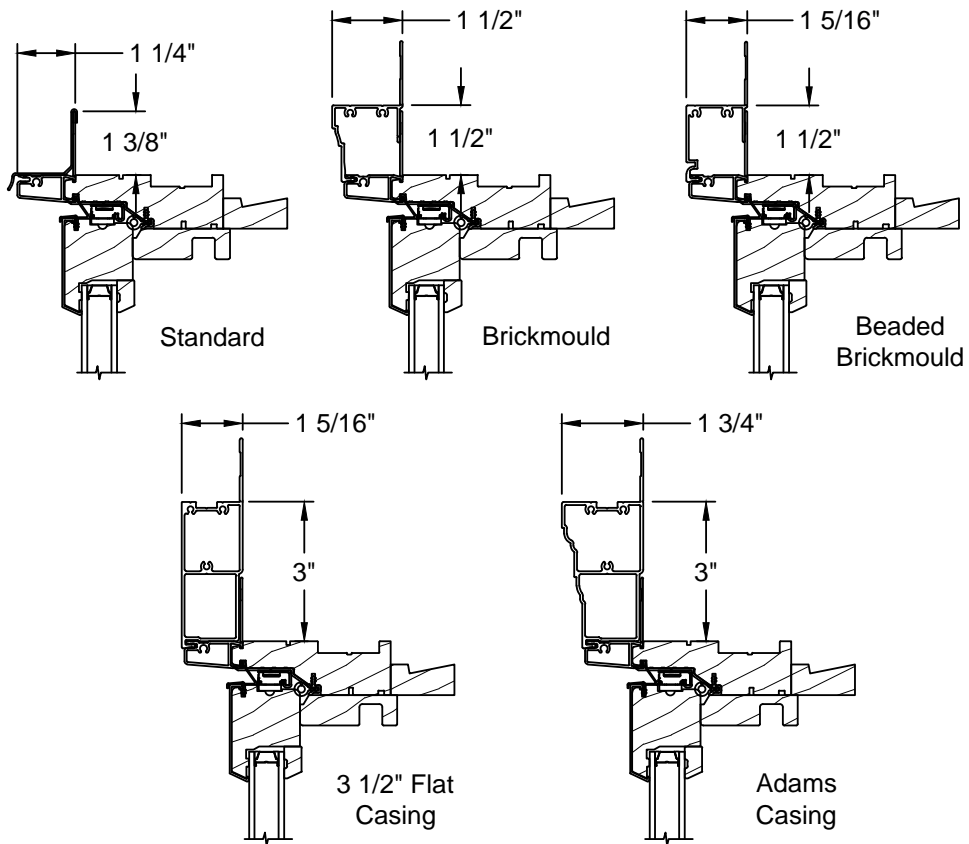

Sill Nose Options

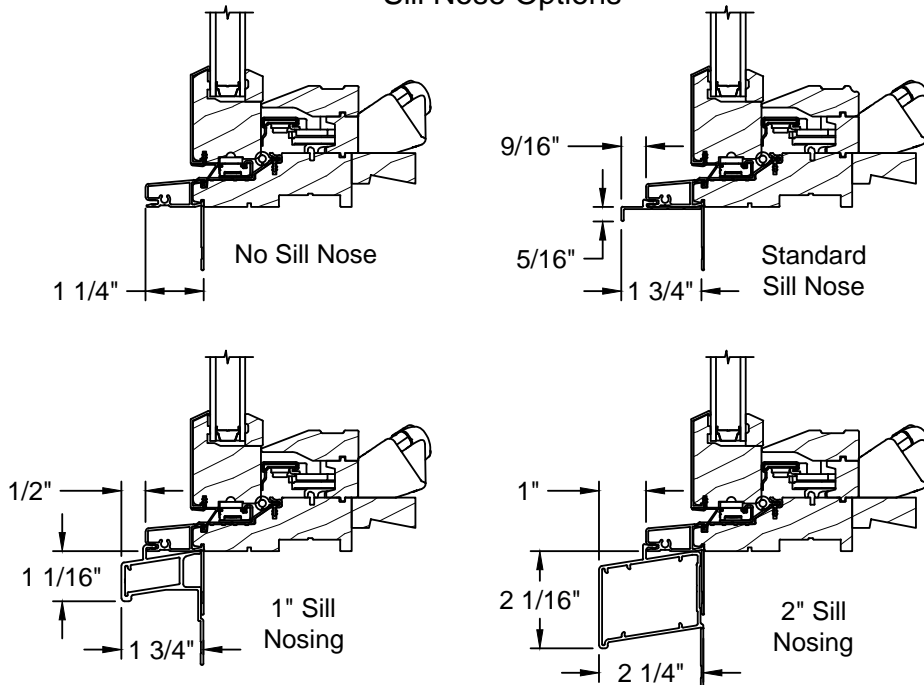



GLASS STOP OPTIONS

---

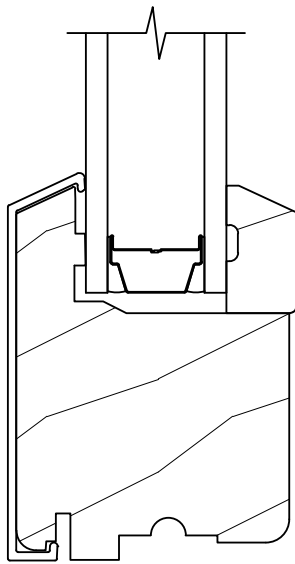

Traditional

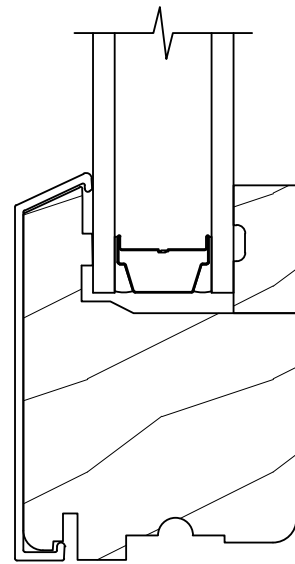

Contemporary



JAMB EXTENDER OPTIONS

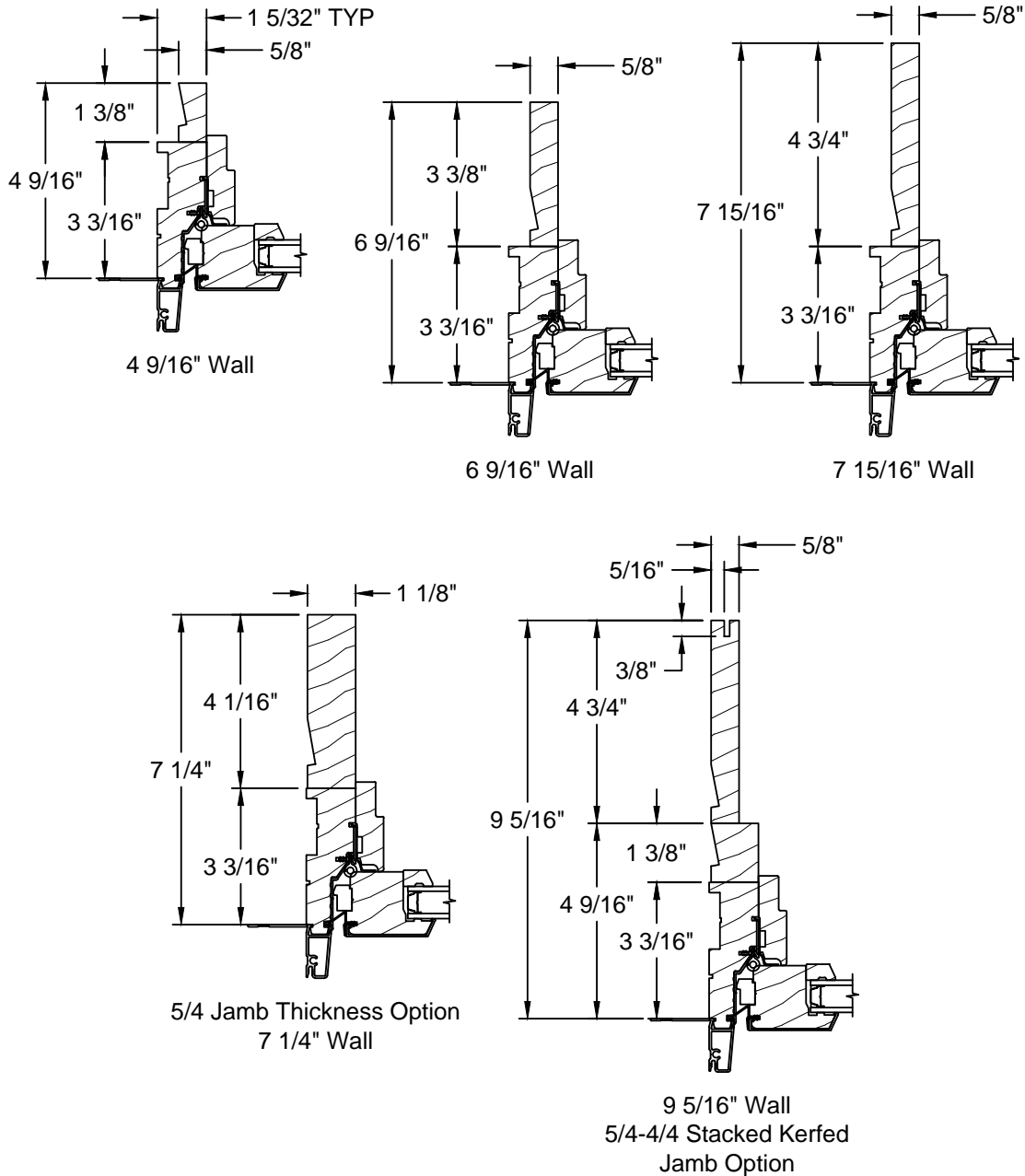

Kerfed Jamb Extension only available on 4/4 or 5/4 options  
 Maximum jamb length for 4/4 is 7 15/16".  
 Maximum jamb length for 5/4 is 7 1/4".  
 Maximum jamb length for 5/4 2 piece stacked is 12".



MULLION OPTIONS - STANDARD

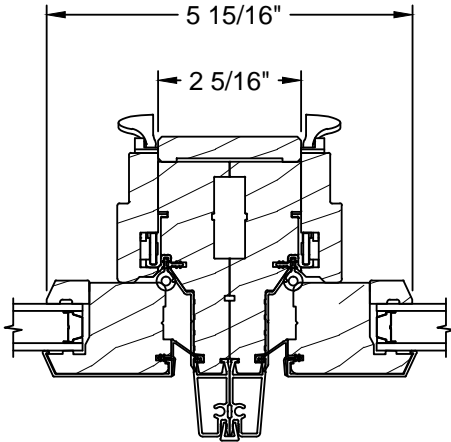

Operating - Operating

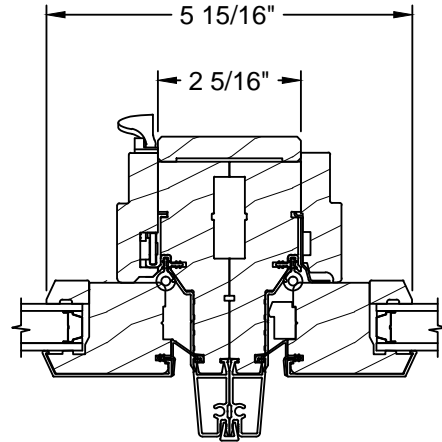

Operating - Stationary

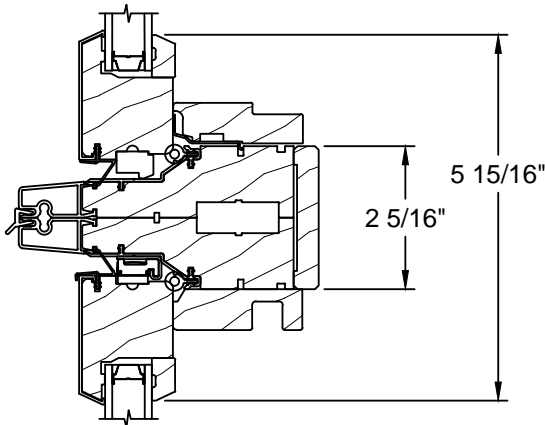

Stationary  
Operating

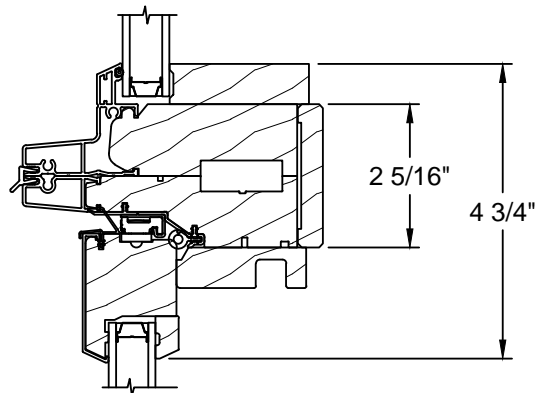

Direct Set  
Operating

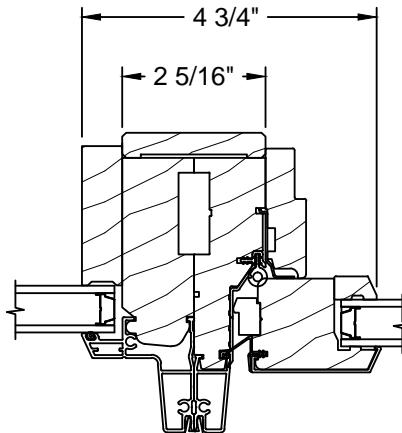

Direct Set - Operating



MULLION OPTIONS - SPREAD

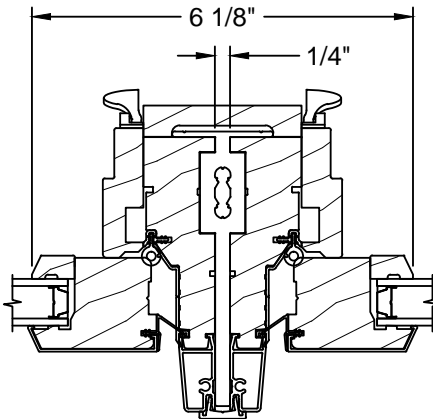

Operating / Operating  
w/ 1/4" Structural Mull Horizontal  
Section

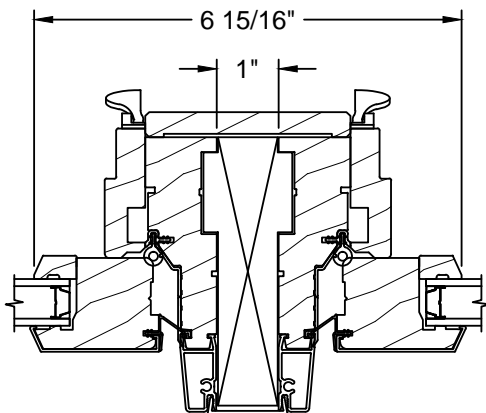

Operating / Operating  
w/ 1" Solid Spread Mull Horizontal  
Section

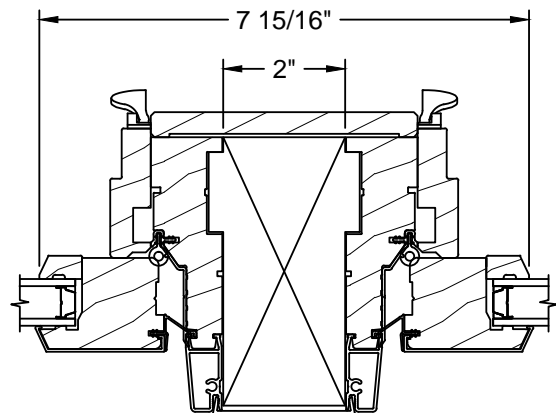

Operating / Operating  
w/ 2" Solid Spread Mull Horizontal  
Section

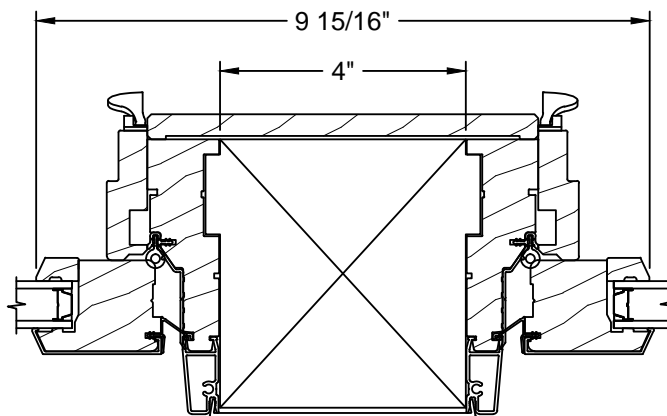

Operating / Operating  
w/ 4" Solid Spread Mull Horizontal  
Section



MULLION OPTIONS - SPREAD

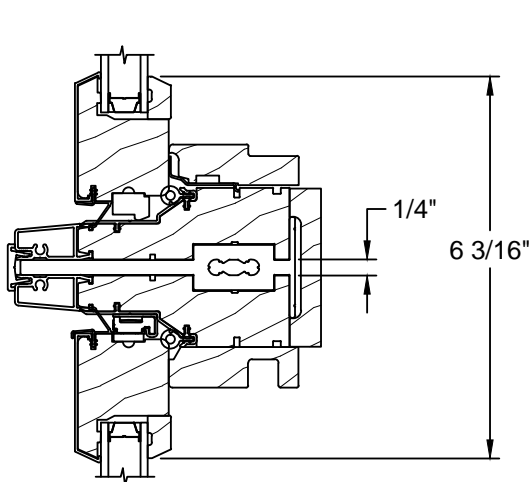

Stationary  
Operating

w/ 1/4" Structural Mull Vertical  
Section

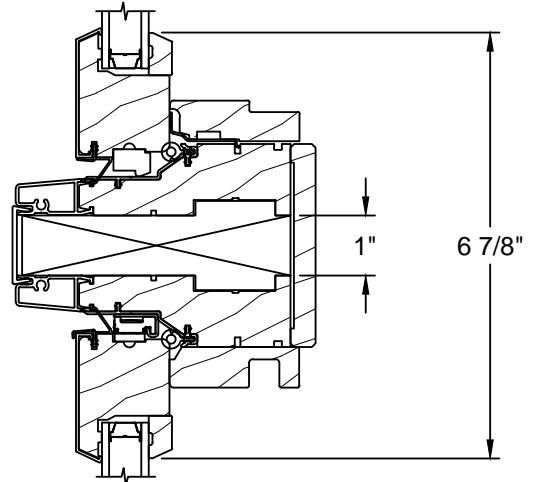

Stationary  
Operating

w/ 1" Solid Spread Mull Vertical  
Section

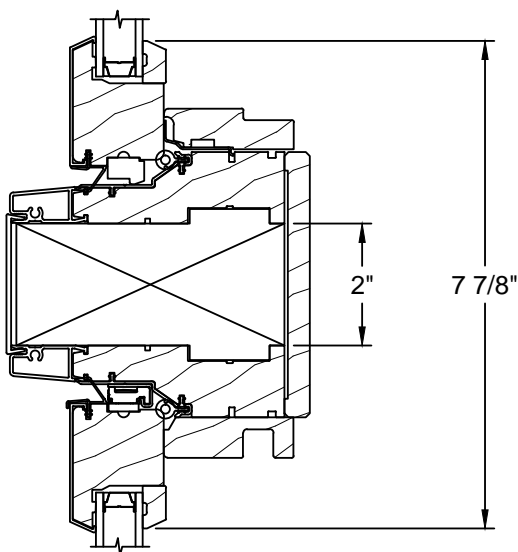

Stationary  
Operating

w/ 2" Solid Spread Mull Vertical  
Section

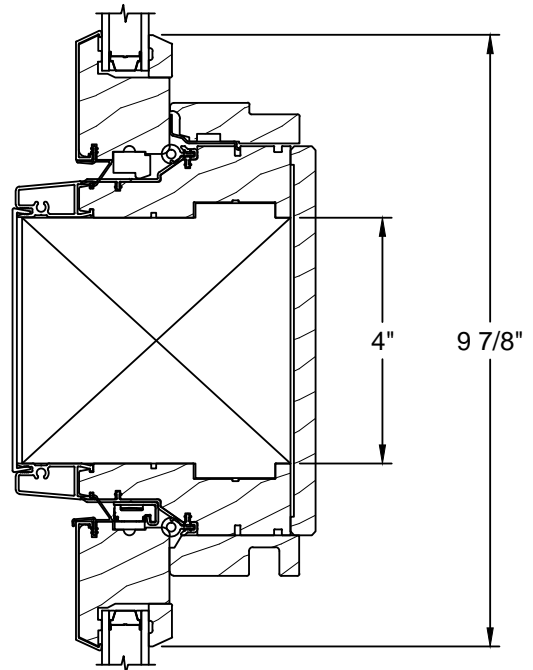

Stationary  
Operating

w/ 4" Solid Spread Mull Vertical  
Section



DIVIDED LITE OPTIONS

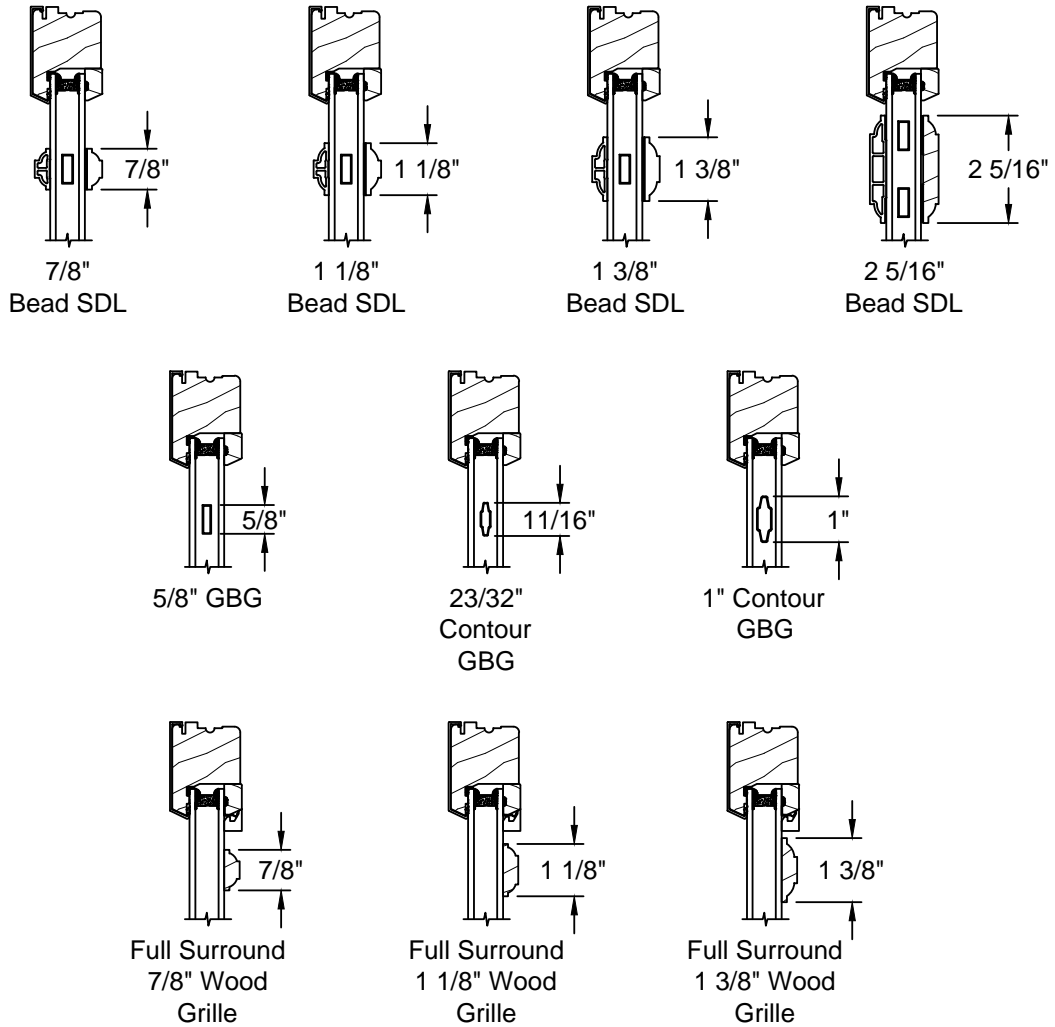



DIVIDED LITE OPTIONS

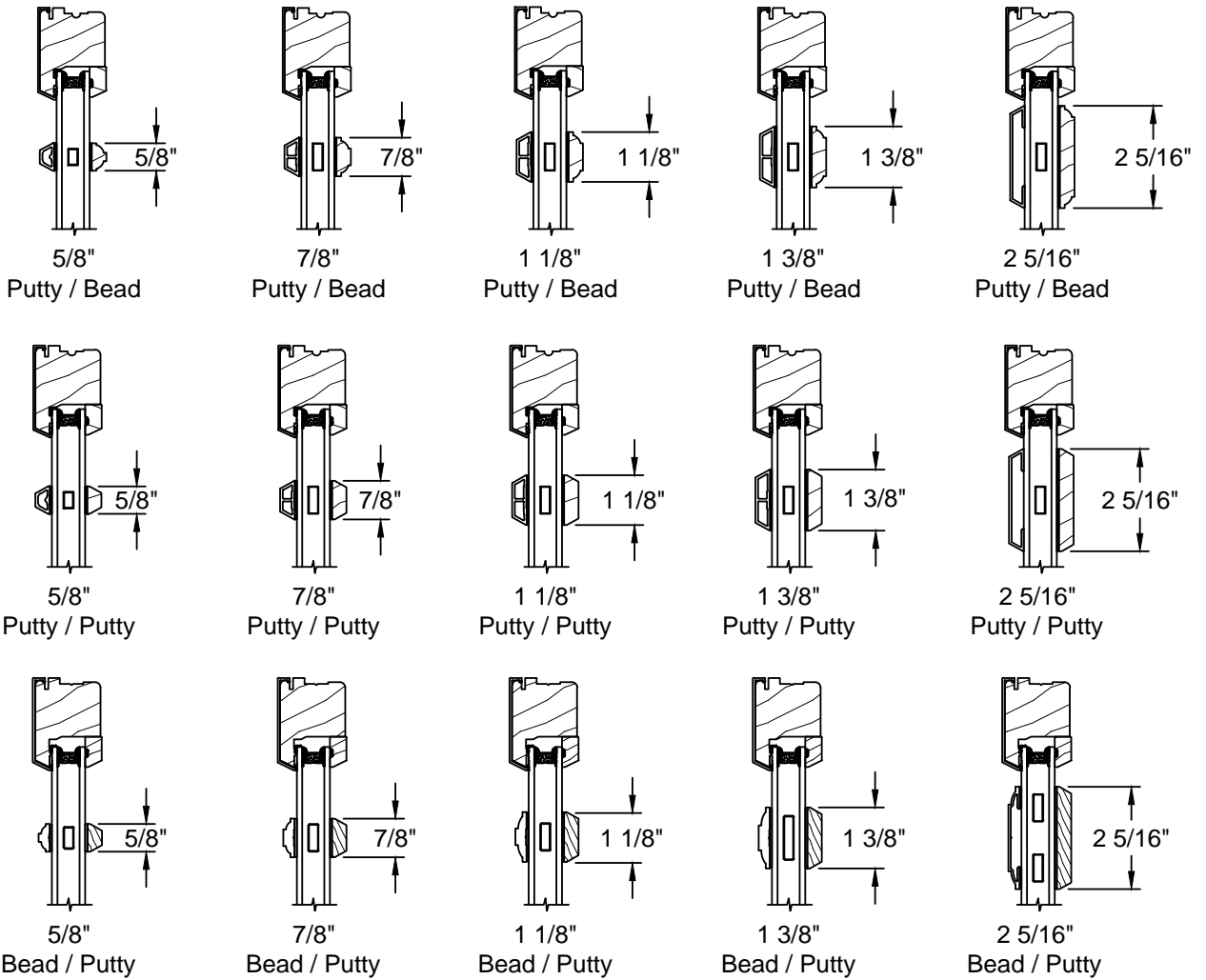



MIN-MAX SIZING - OPERATOR

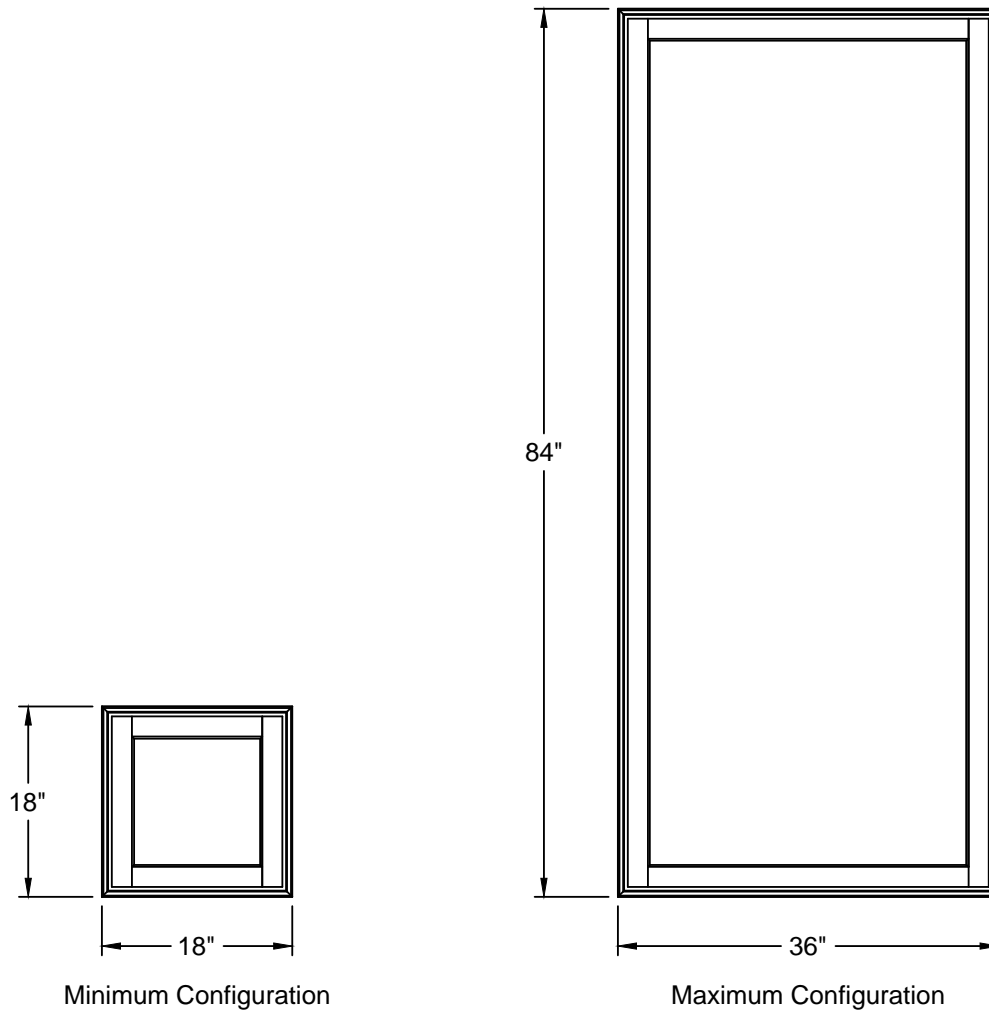

OPERATOR WIDTH CONFIGURATIONS			
18"	20"	24"	28"
30"	32"	36"	

OPERATOR HEIGHT CONFIGURATIONS			
18"	20"	24"	28"
30"	36"	42"	48"
54"	60"	66"	72"
78"	84"		

Note: Limited operation configurations w/ 20 degree opening sash limiter: [32" x 84"] [36" x 78"] [36" x 84"]



MIN-MAX SIZING - PICTURE

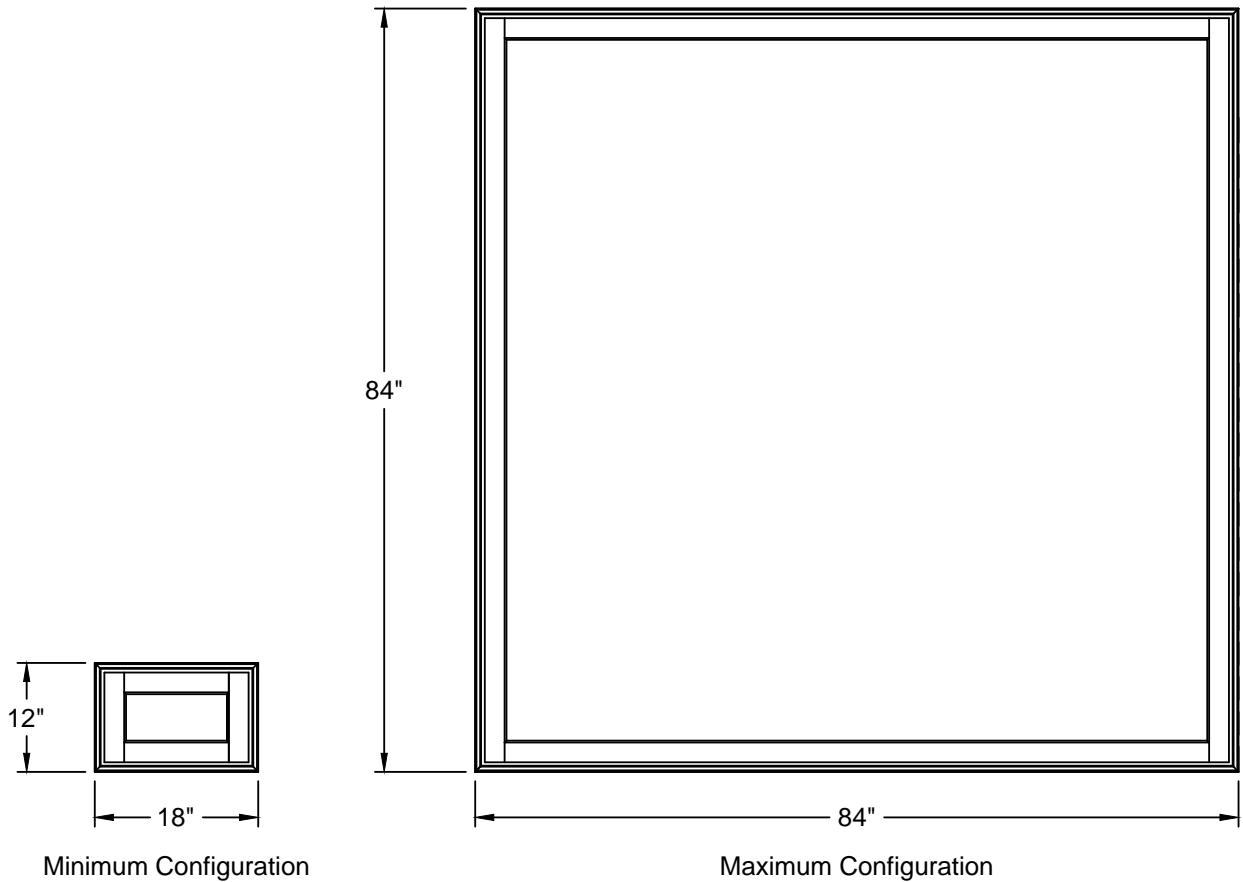

PICTURE WIDTH CONFIGURATIONS			
18"	20"	24"	28"
30"	32"	36"	42"
48"	54"	60"	66"
72"	84"		

PICTURE HEIGHT CONFIGURATIONS			
12"	18"	20"	24"
28"	30"	36"	42"
48"	54"	60"	66"
72"	78"	84"	



OPERATING - VERTICAL SECTION

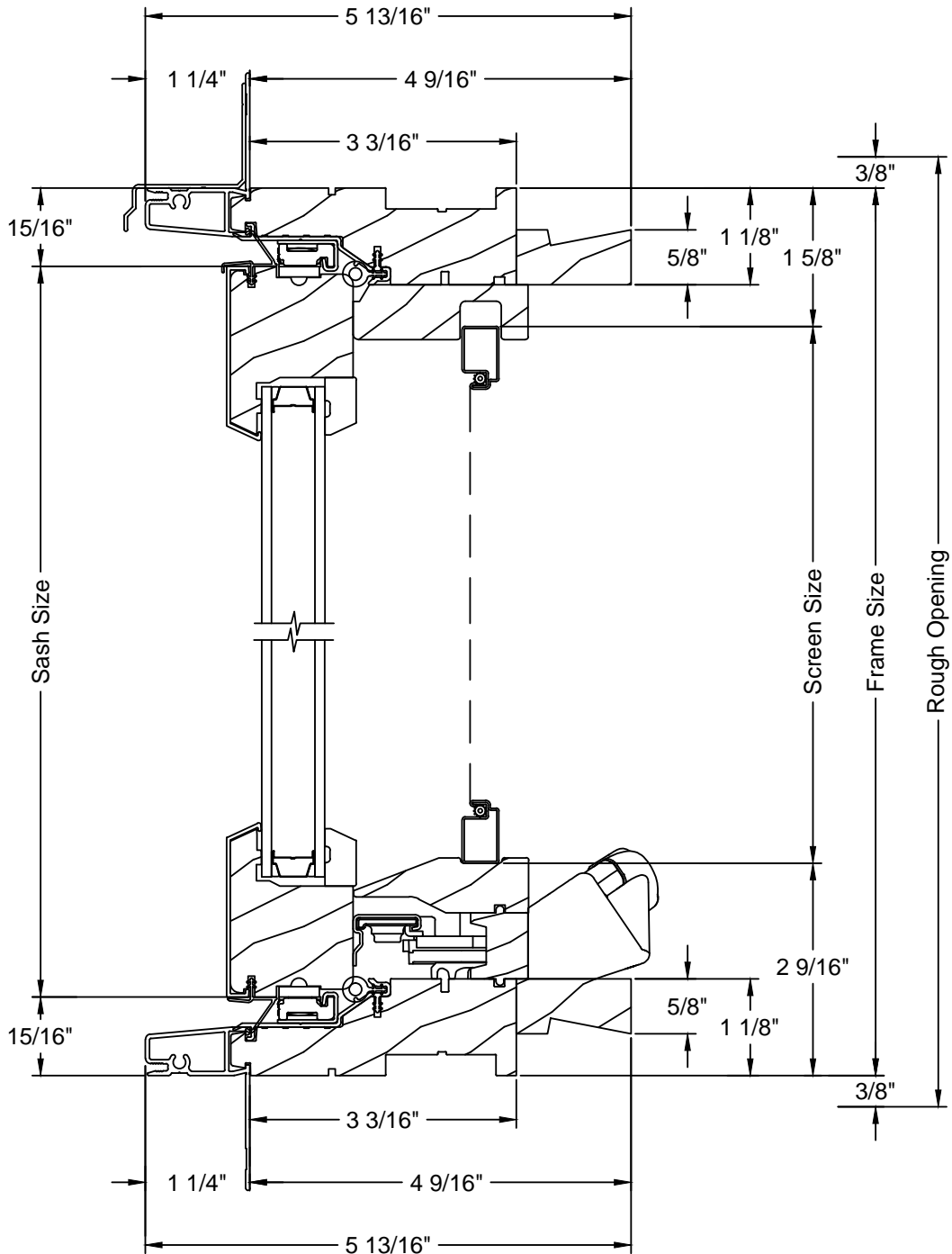



OPERATING - HORIZONTAL SECTION

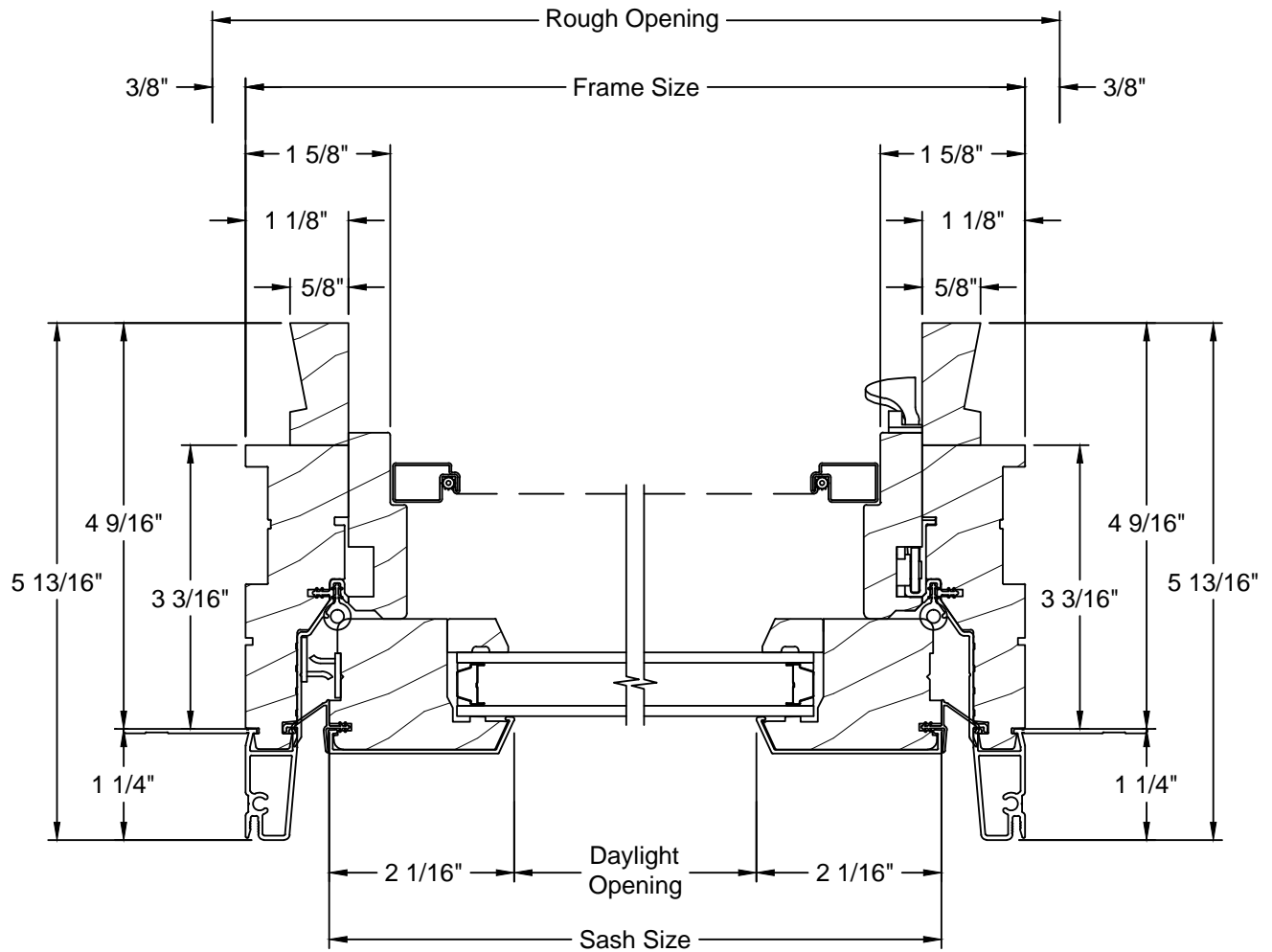



OPERATING IMPACT - VERTICAL SECTION

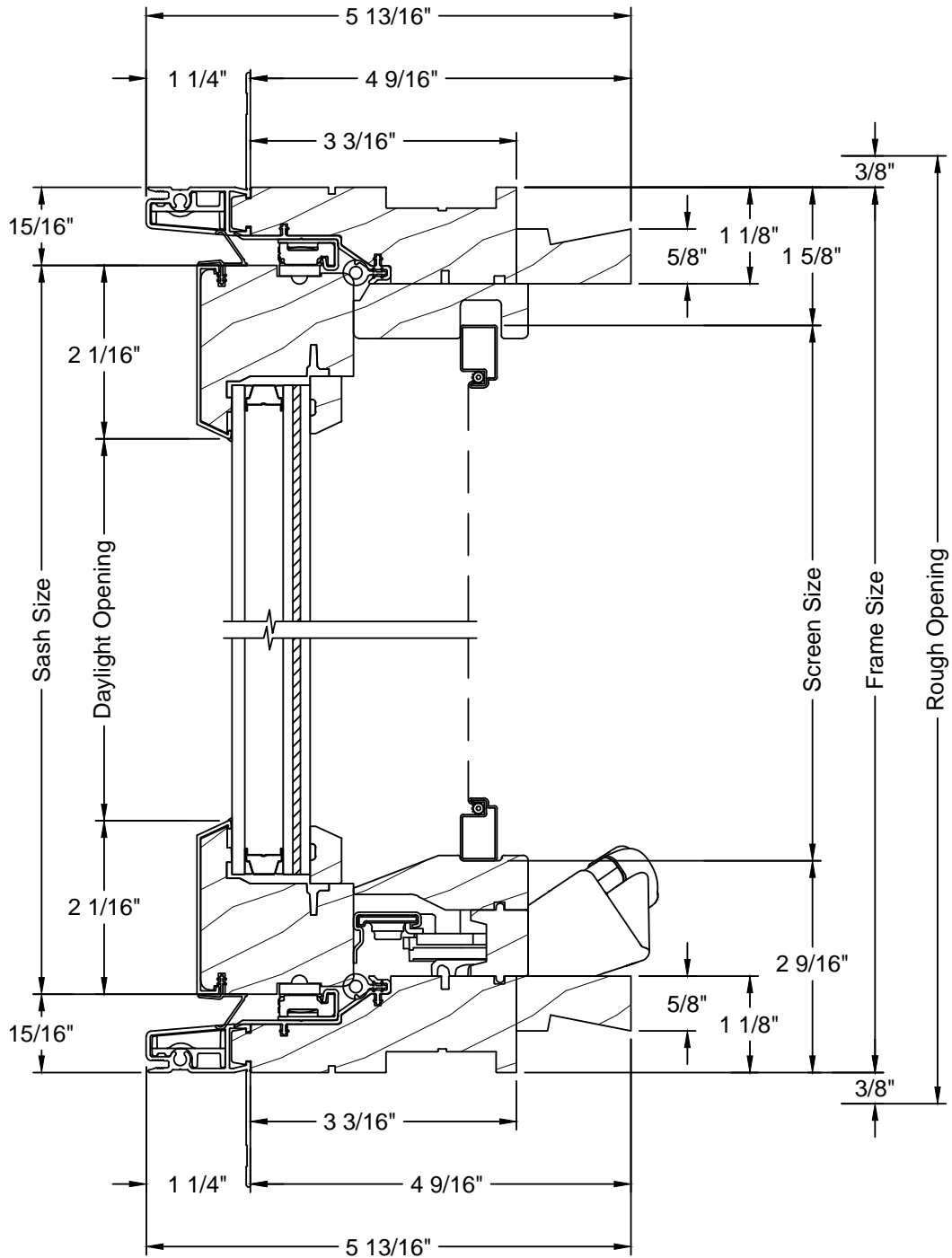



OPERATING IMPACT - HORIZONTAL SECTION

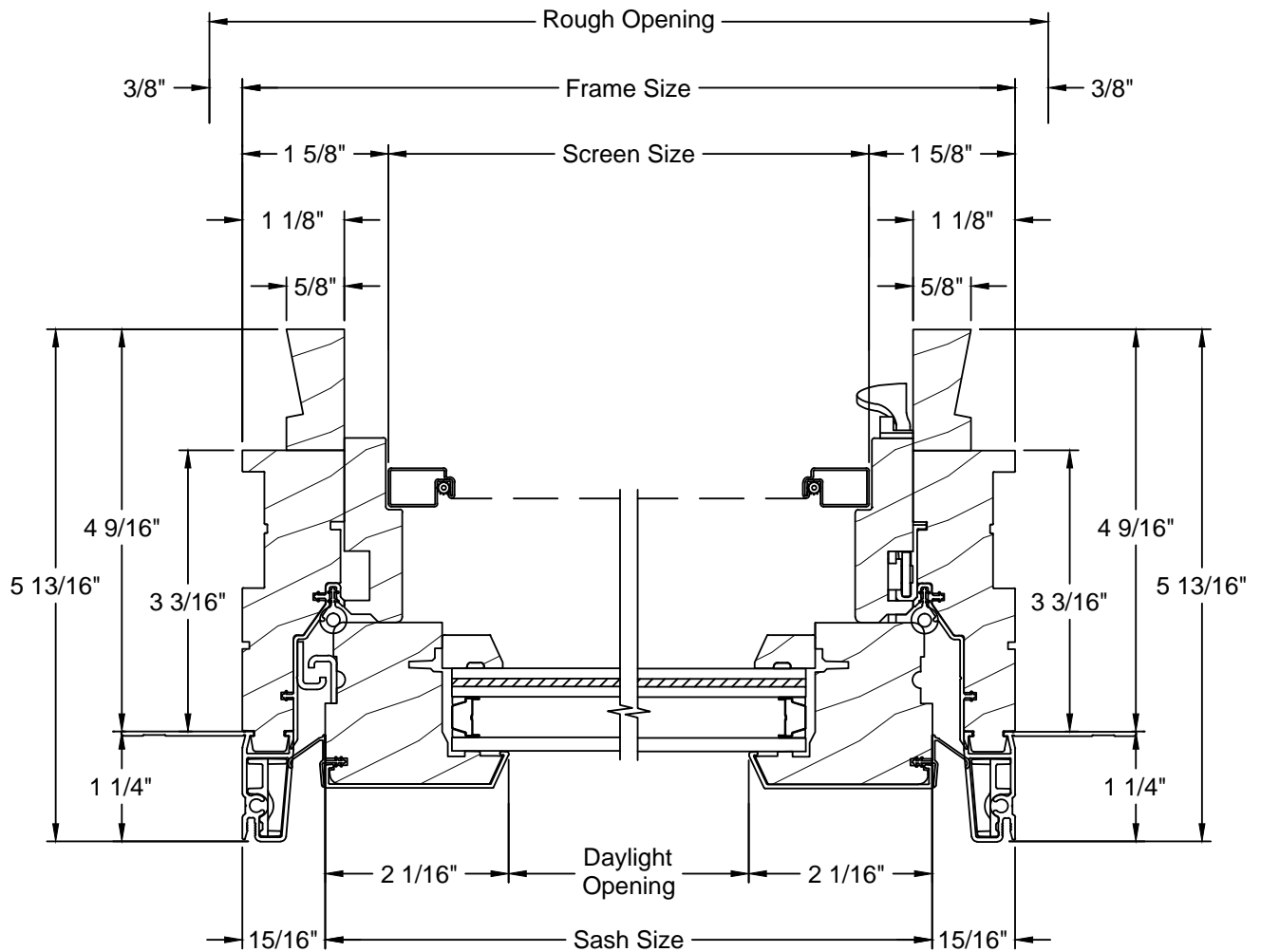



FIXED - VERTICAL SECTION

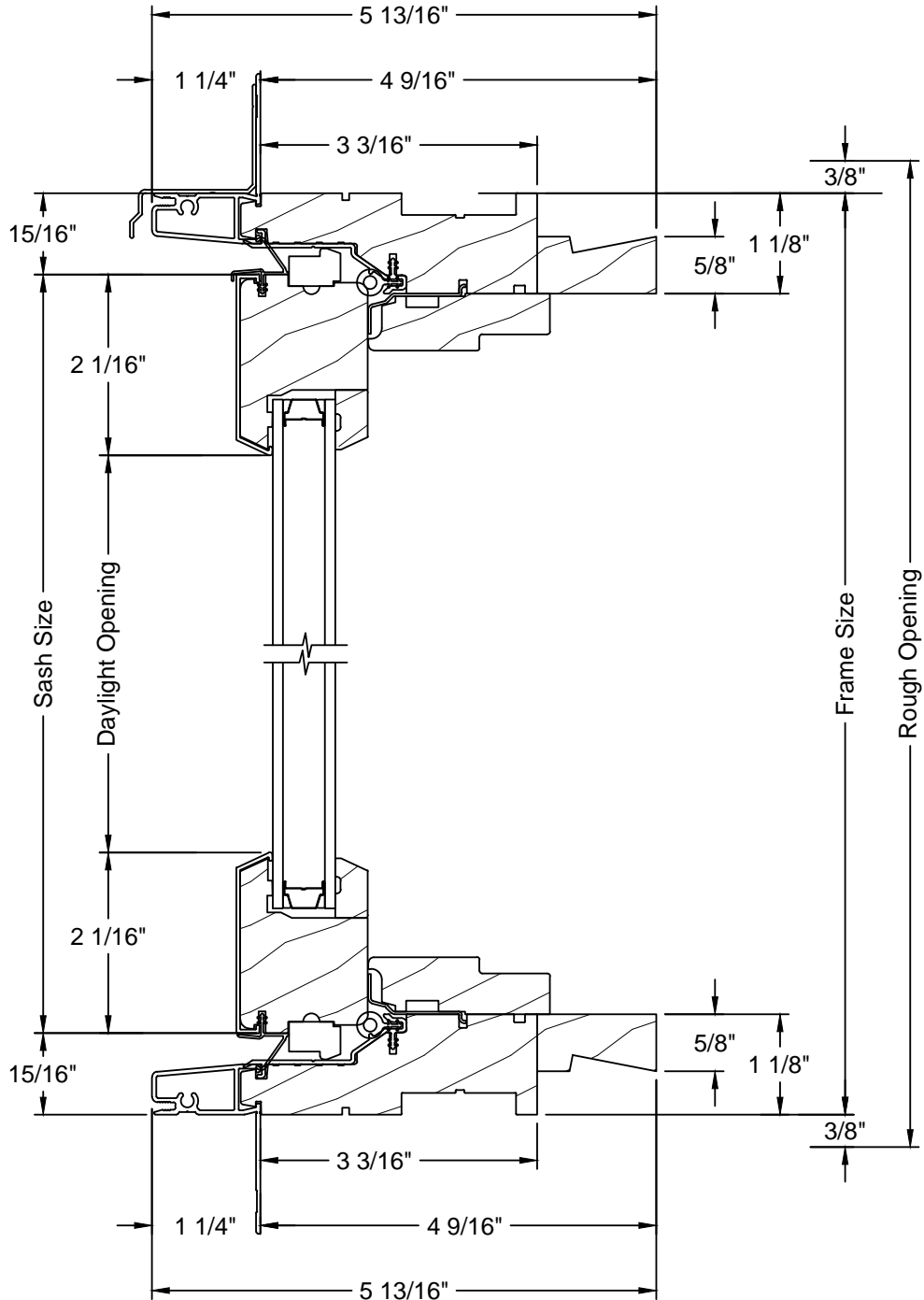



FIXED - HORIZONTAL SECTION

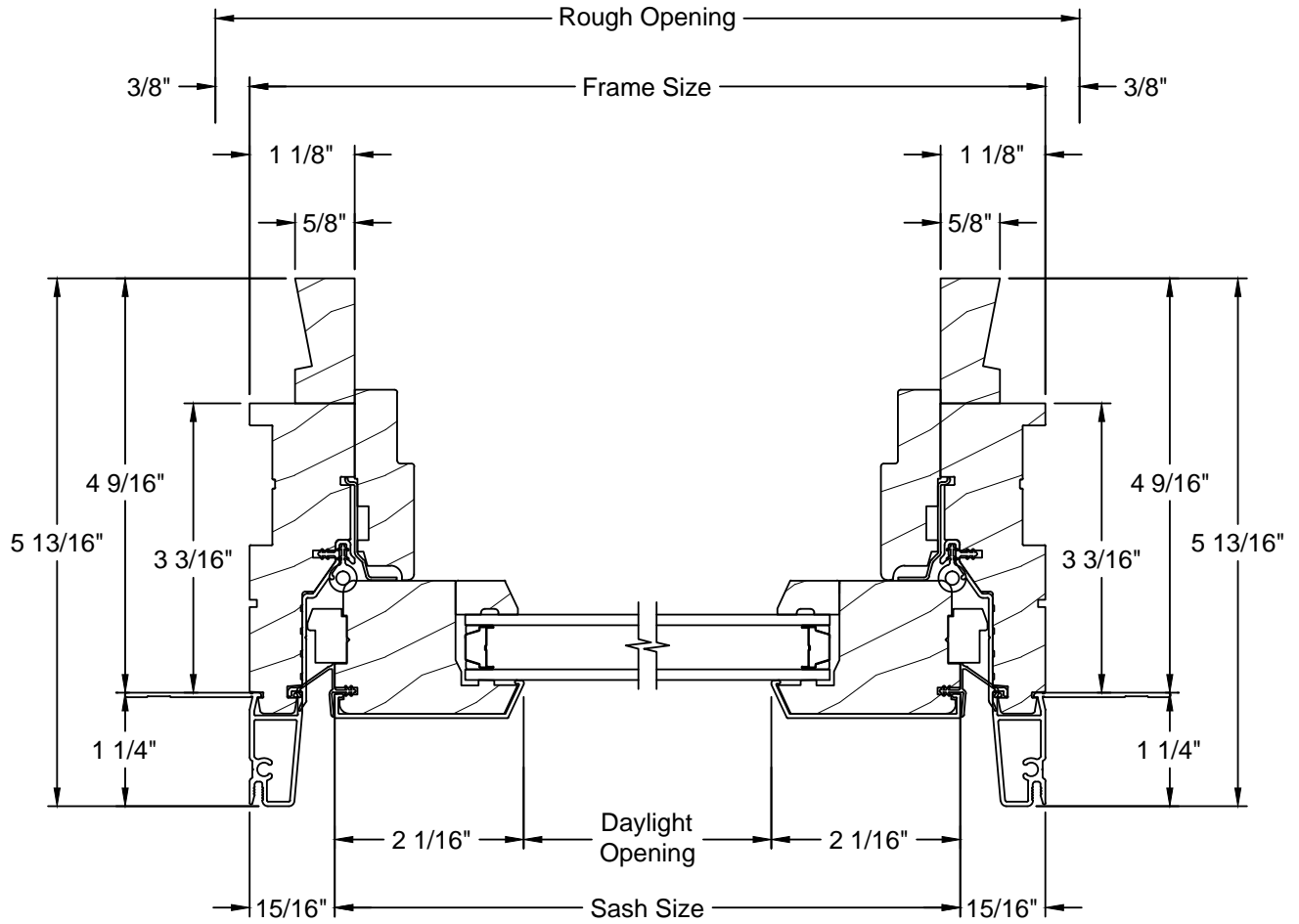



FIXED IMPACT - VERTICAL SECTION

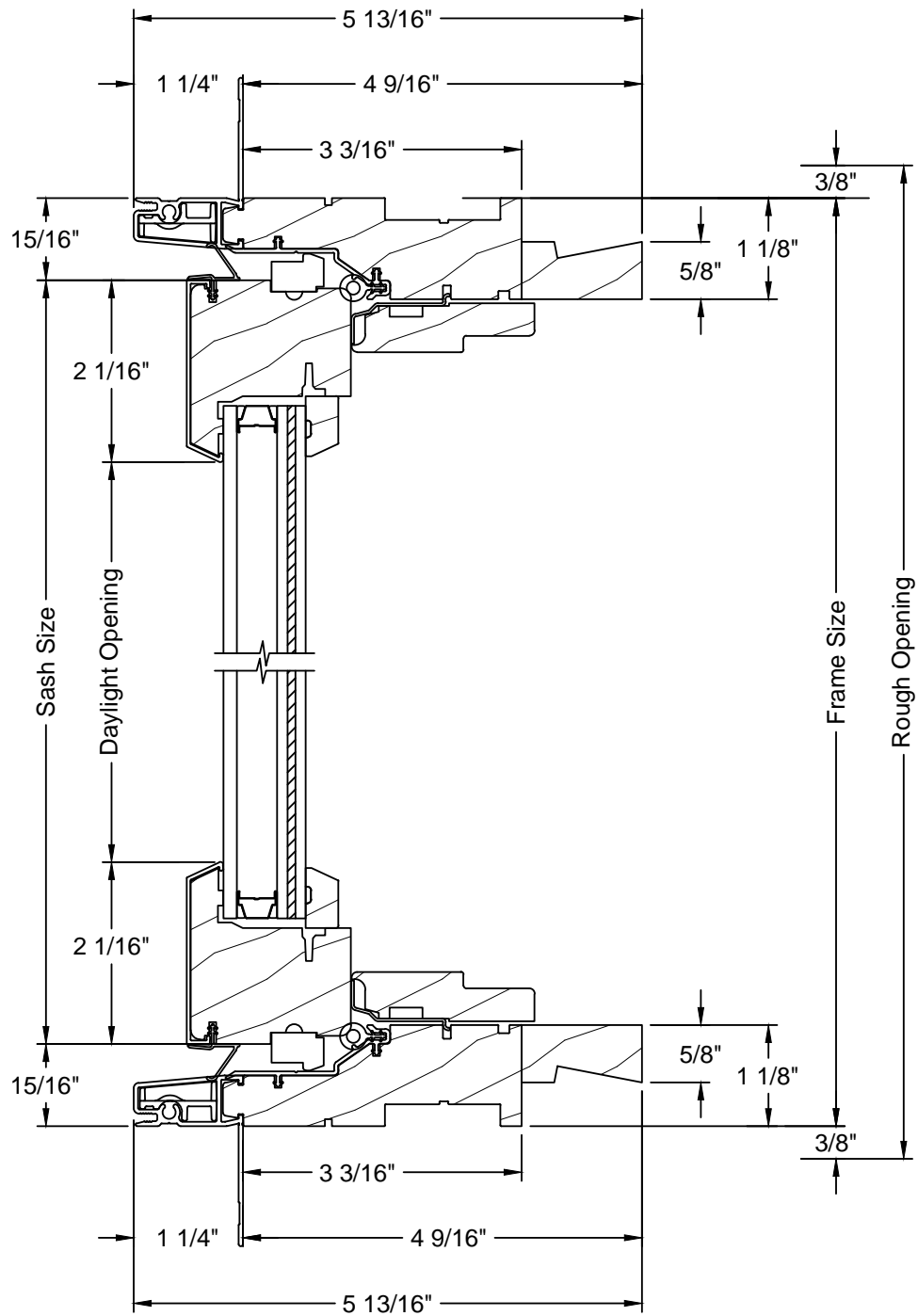



FIXED IMPACT - HORIZONTAL SECTION

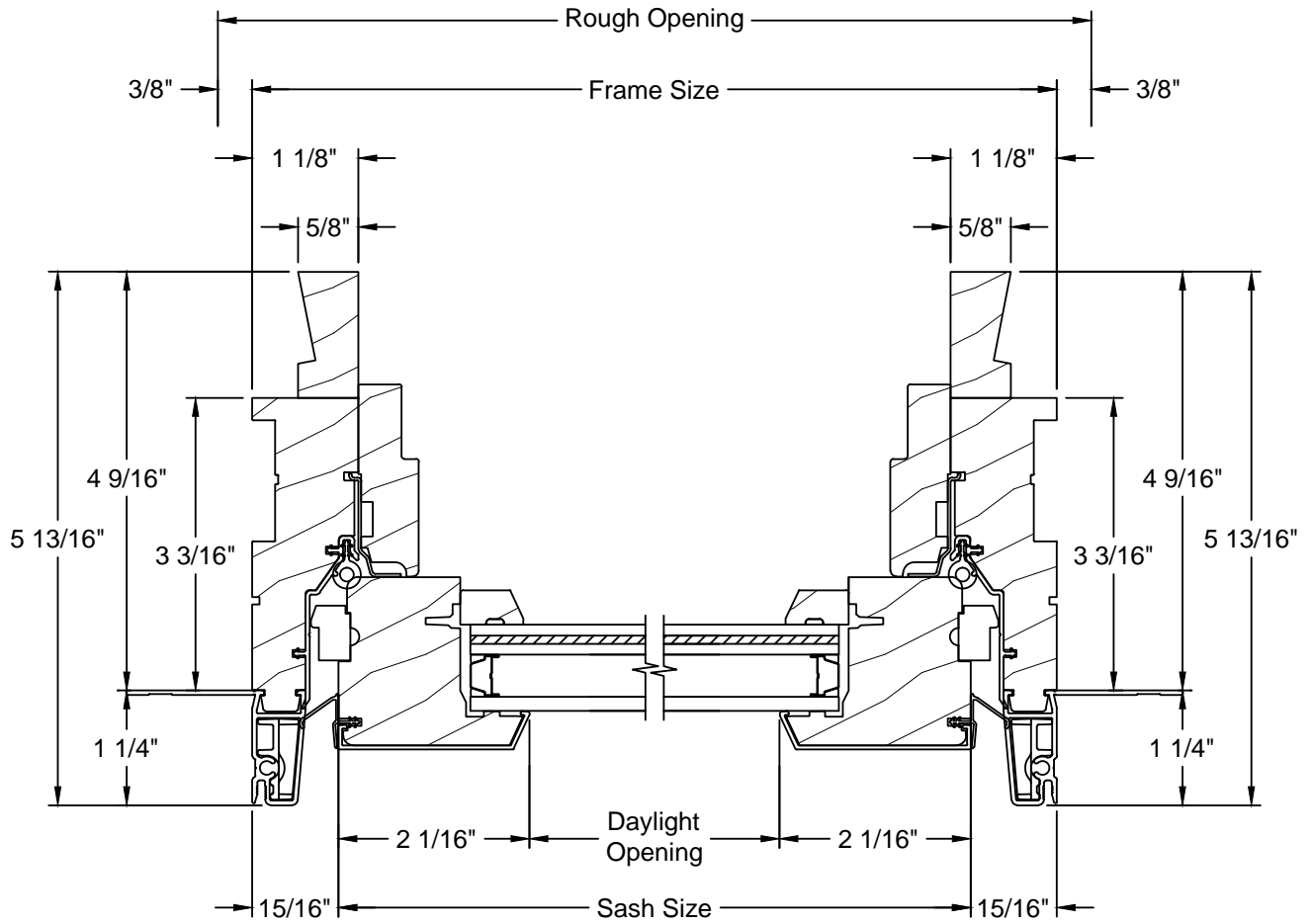



PUSHOUT - VERTICAL SECTION

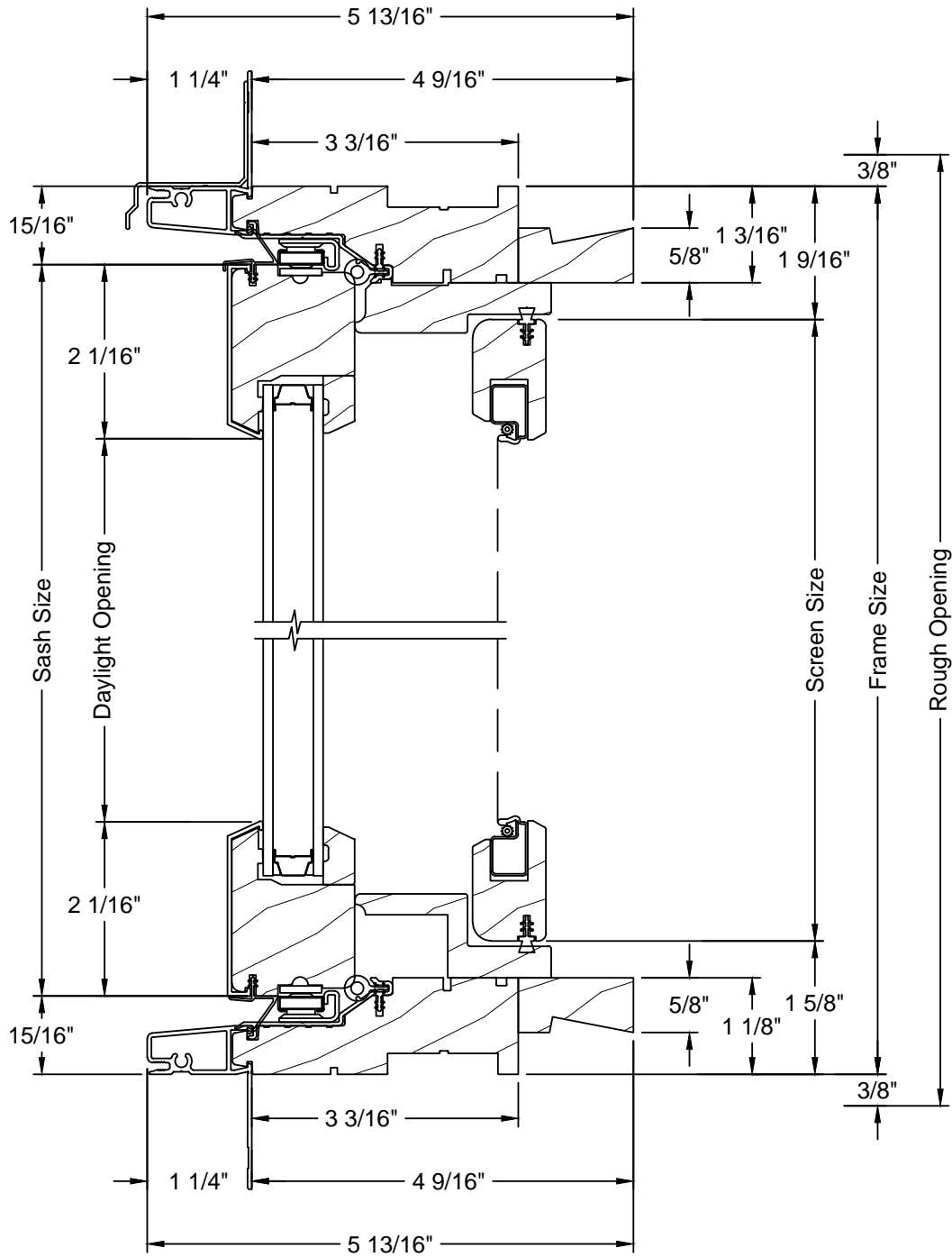



PUSHOUT - HORIZONTAL SECTION

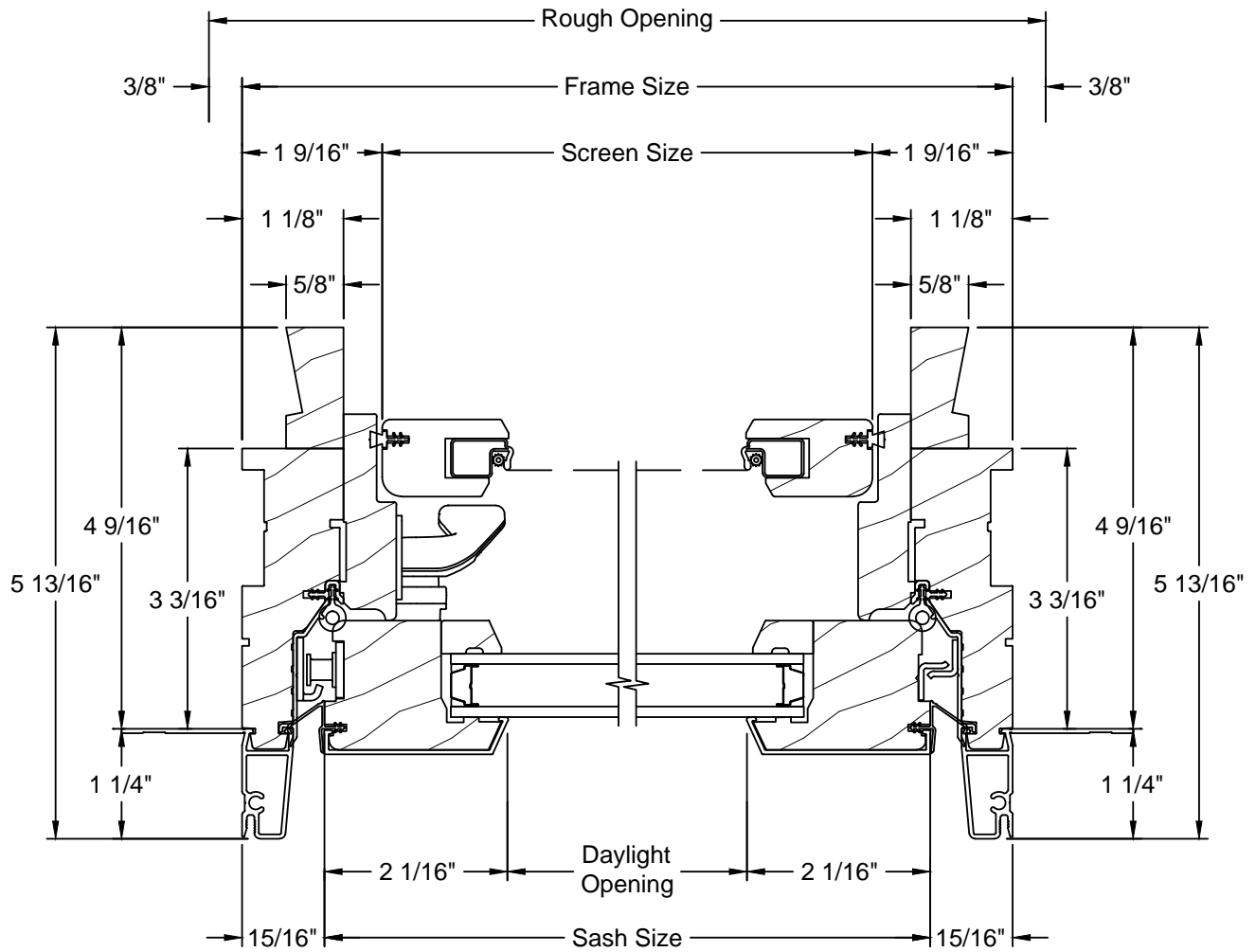



PUSHOUT FIXED - VERTICAL SECTION

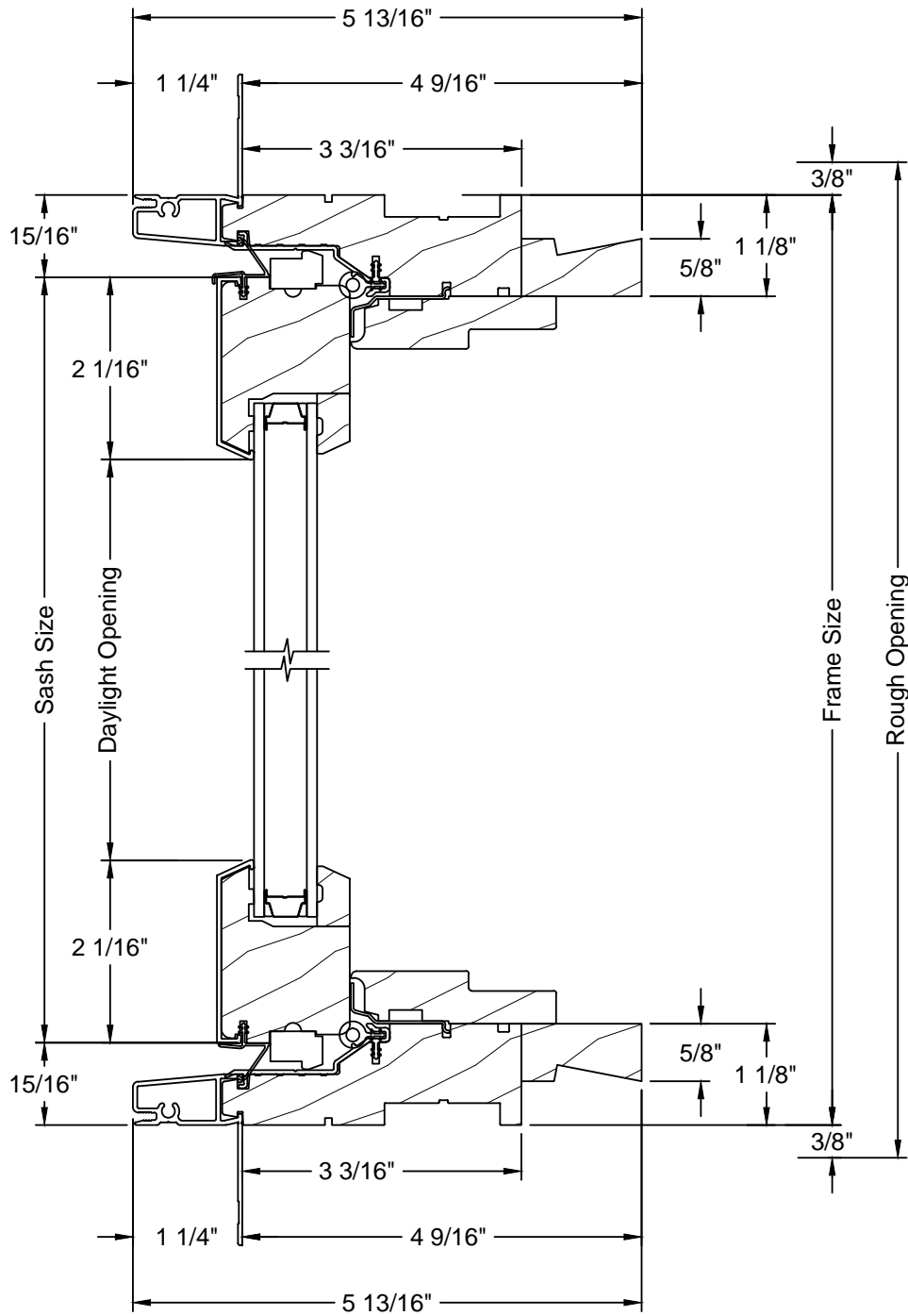



PUSHOUT FIXED - HORIZONTAL SECTION

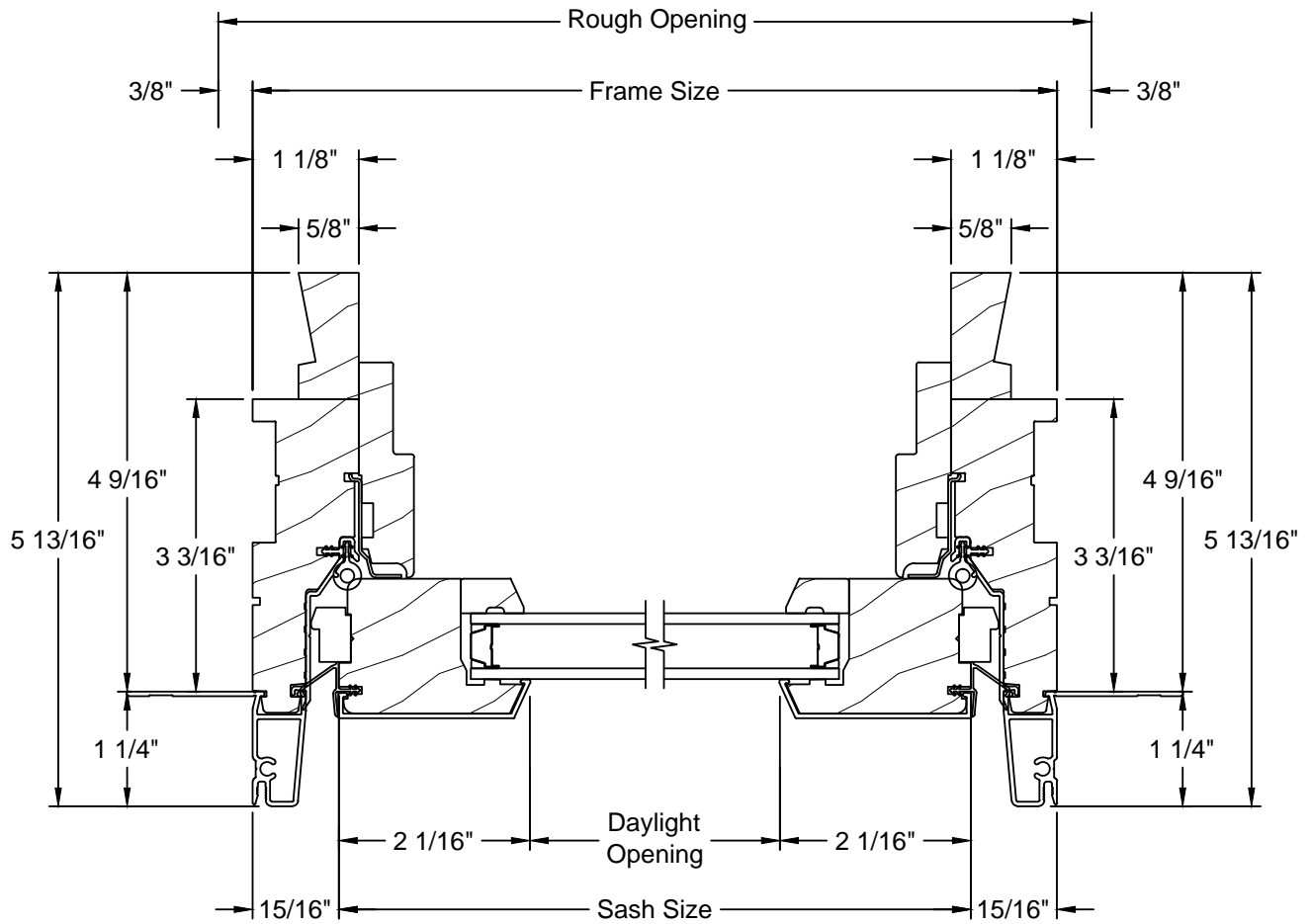



RADIUS TOP - VERTICAL SECTION

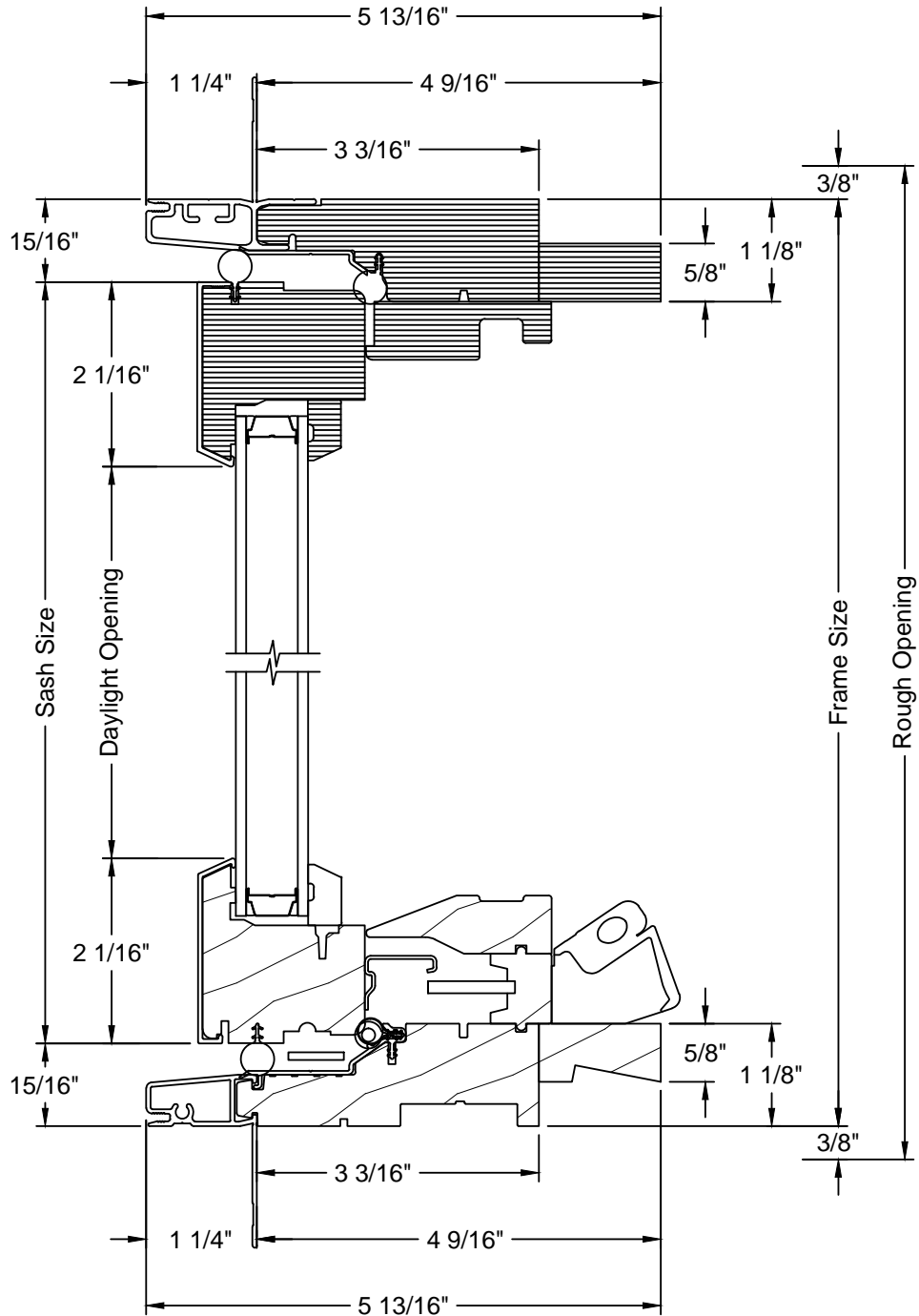





BAY & BOW - VERTICAL SECTION

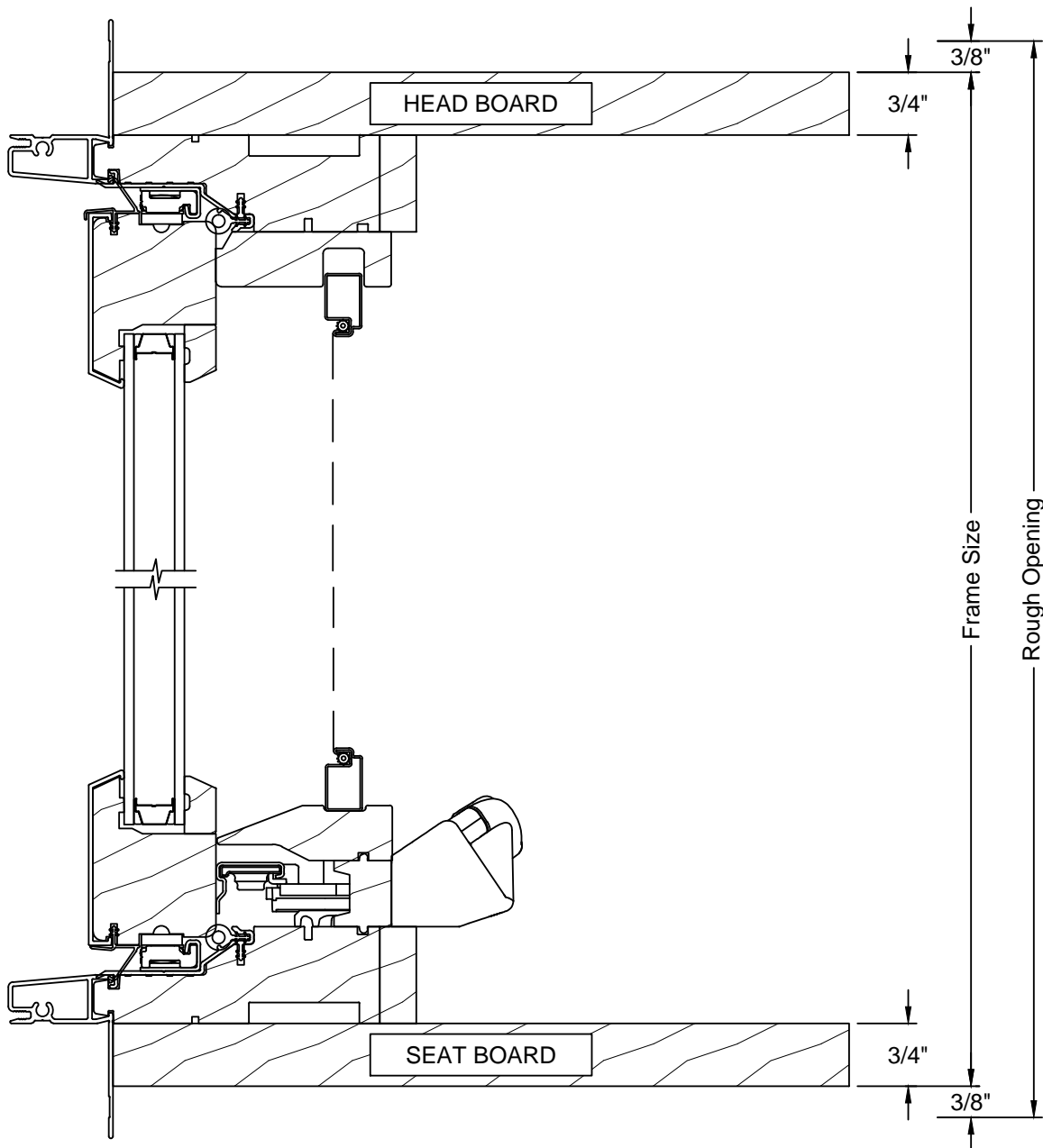



30° BAY - HORIZONTAL SECTION

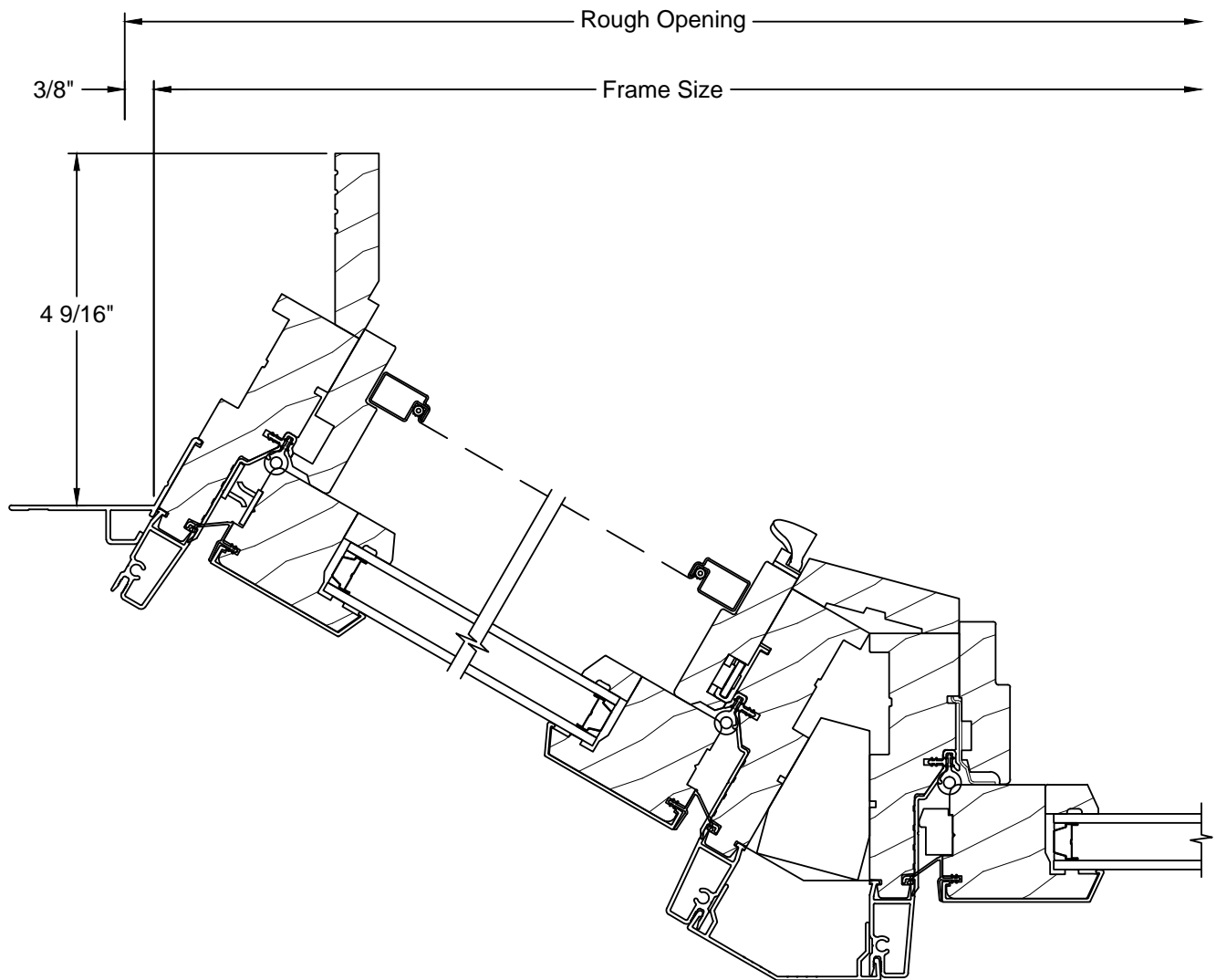



45° BAY - HORIZONTAL SECTION

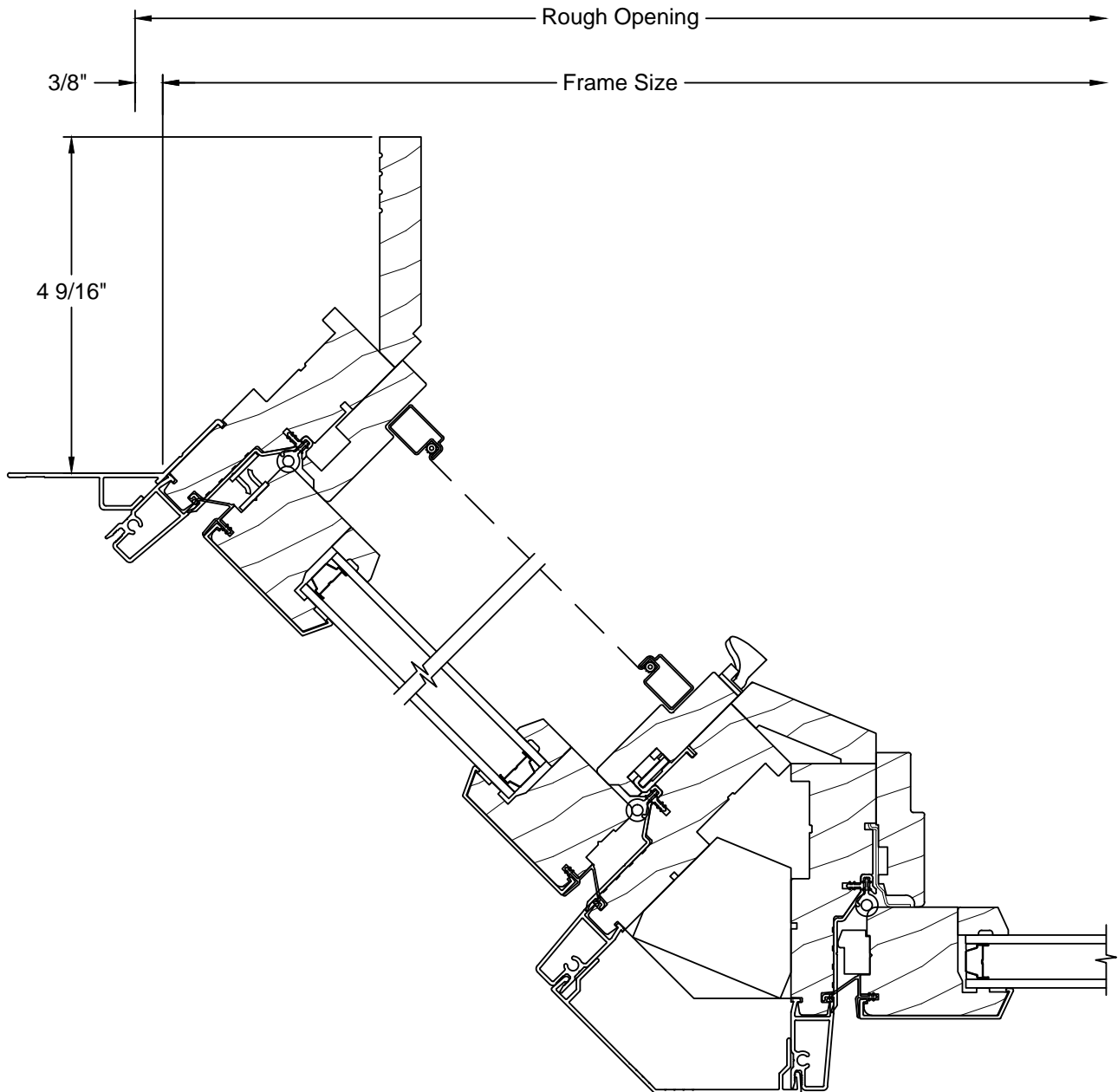



BOW 3 WIDE - HORIZONTAL SECTION

---

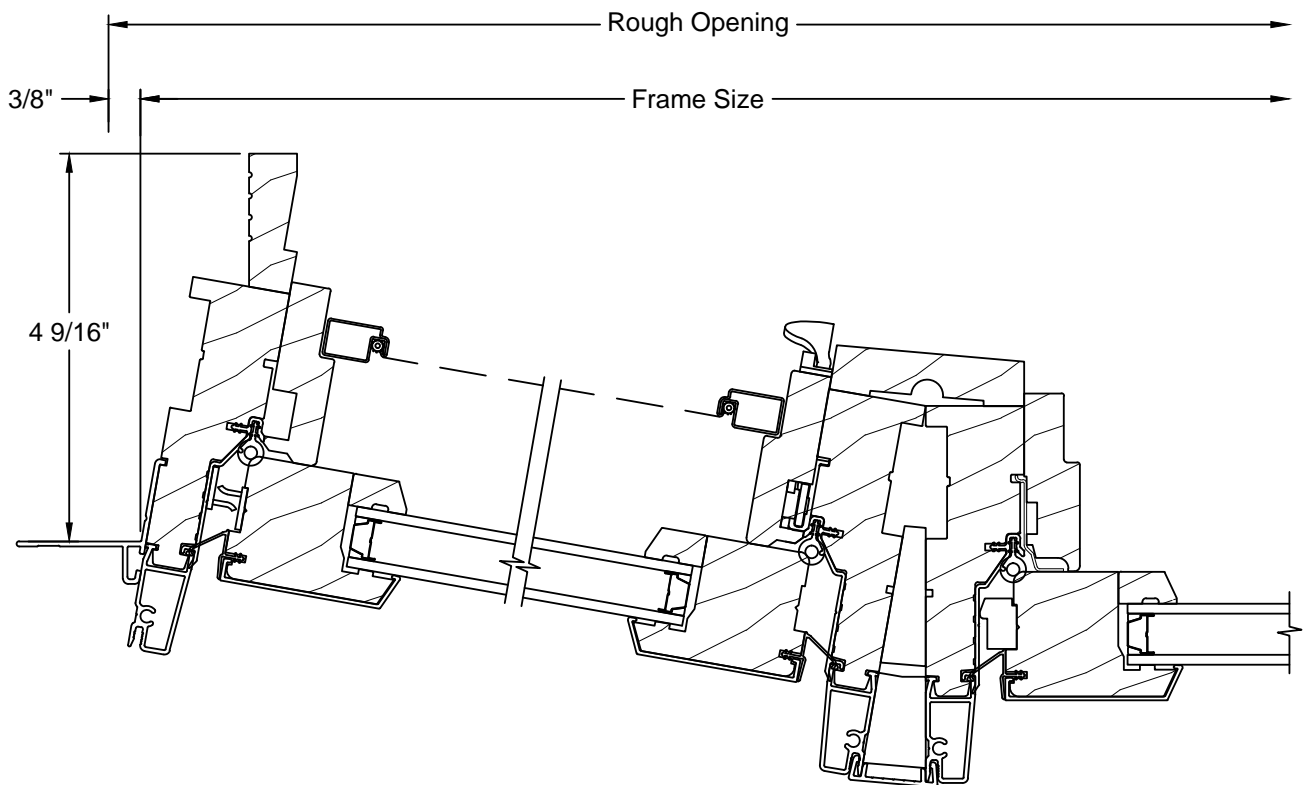



BOW 4 WIDE - HORIZONTAL SECTION

---

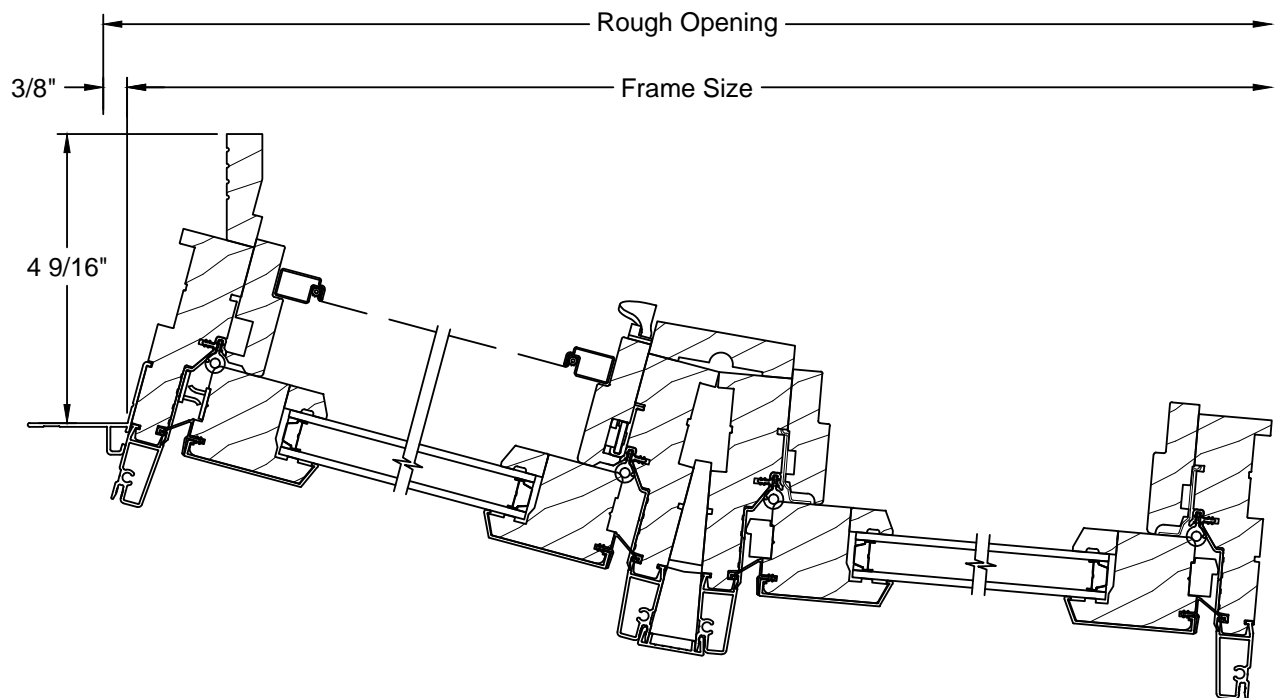



BOW 5 WIDE - HORIZONTAL SECTION

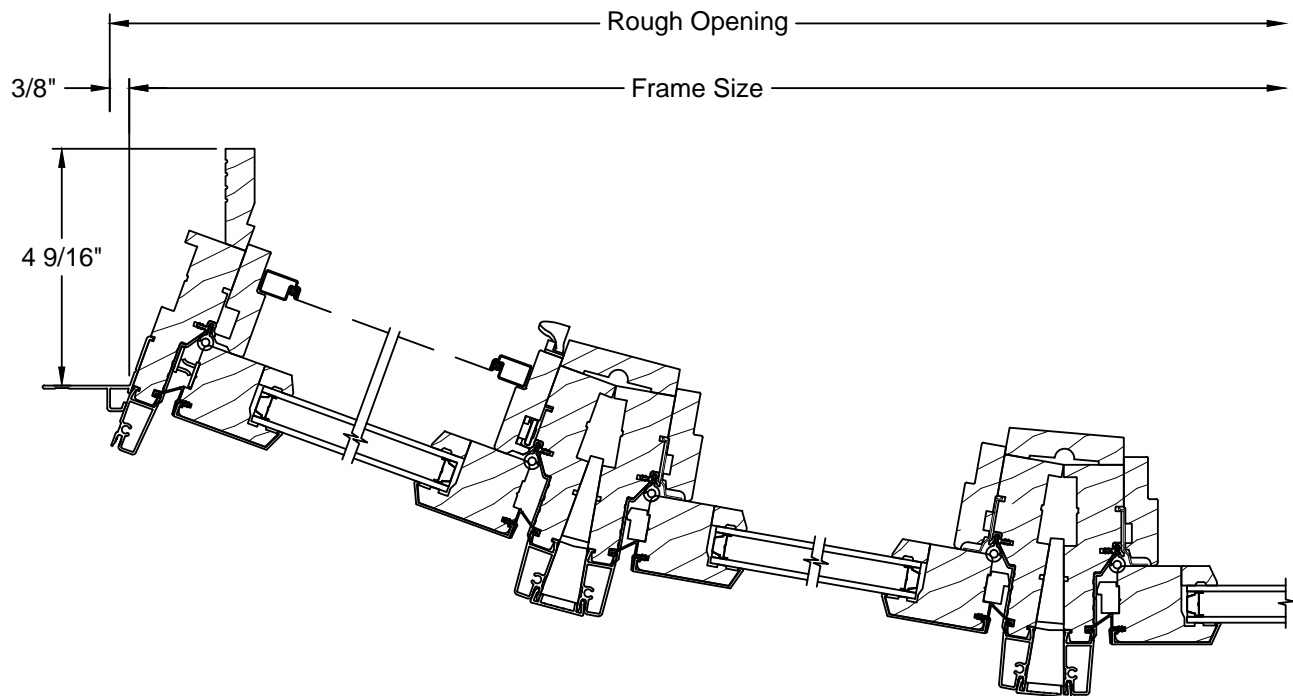



BOW 6 WIDE - HORIZONTAL SECTION

---

