



# F L Y N N

ARCHITECT INC.

## SITE INSTRUCTION

SIN NO: **24**  
 CONTRACTOR: **Mr. Pat Newton**  
**Talco Building Innovations Inc.**  
 4728 Bank Street  
 Ottawa ON K1T 3W7

CLIENT: **Mr. Ryan Firlotte**  
 Enterprise Holdings  
 Group Property Developemnt & Facilities Specialist  
 2300 Stevenage Dr.  
 Ottawa ON K1G 3W3

PROJECT NAME: **225 Huntmar**  
**Ottawa, Ontario**

PROJECT NO: 15-010  
 DATE: 2020, Jun. 22

The following items are proposed changes to the contract documents previously issued for this project. Unless noted below, work is not to proceed until authorized by a change order. All material and workmanship are to be as described in the contract documents unless otherwise stated. Please submit an itemized quotation for changes to the tender price and/or to the project schedule, and within 5 calendar days of the date hereon.

REASON FOR CHANGE: Contractor Request / Site Coordination

1. Further to Contractor's Information Request #21 dated 2020 Jun. 17.  
 Supply and install hose bib as specified in attached mechanical and electrical site instruction #2 from Antares Engineering; regarding hose bib installation in truck wash bay.
2. Further to Contractor's Information Request #21 dated 2020 Jun. 17.  
 Supply and install hose bib as specified in attached mechanical and electrical site instruction #2 from Antares Engineering; regarding relocation of force flow heater in front vestibule.

END OF SITE INSTRUCTION

PER.....  
 Jason C. Flynn, OAA, MRAIC  
 Jason C. Flynn Architect Inc.  
 Email: j.flynn@flynnarchitect.com

DISTRIBUTION: as above





## SITE INSTRUCTION NOTICE

---

<b>CIN No:</b>	Two (2)	<b>Our Project Ref:</b>	15-610
<b>Date:</b>	19 June 2020	<b>Your Project Ref:</b>	Enterprise Rent-a-Car

---

**Project:** Enterprise Rent-a-Car  
225 Huntmar Drive  
Ottawa, Ontario

---

**Contractor:** TALCO Building Innovations Ltd.

---

*These instructions are not intended to alter the contract nor vary the contract in any way. They are issued solely to ensure and facilitate compliance with the contract requirements.*

---

Contemplated Work:

**Regarding: CIR#21 & CIR#22**

1. CIR#21.  
Provide regular wall hydrant c/w vacuum breaker (Attached).
2. CIR#22.  
Relocate force flow heater to mechanical room wall (as shown on CIR#22 Item #2).

----- End of SIN No. 2 -----

Per: Slavo. J. Samel  
ANTARES Engineering Group Inc.



# Z1341XL WALL FAUCET

SPECIFICATION SHEET

TAG \_\_\_\_\_

Dimensional Data (inches and [mm]) are Subject to Manufacturing Tolerances and Change Without Notice

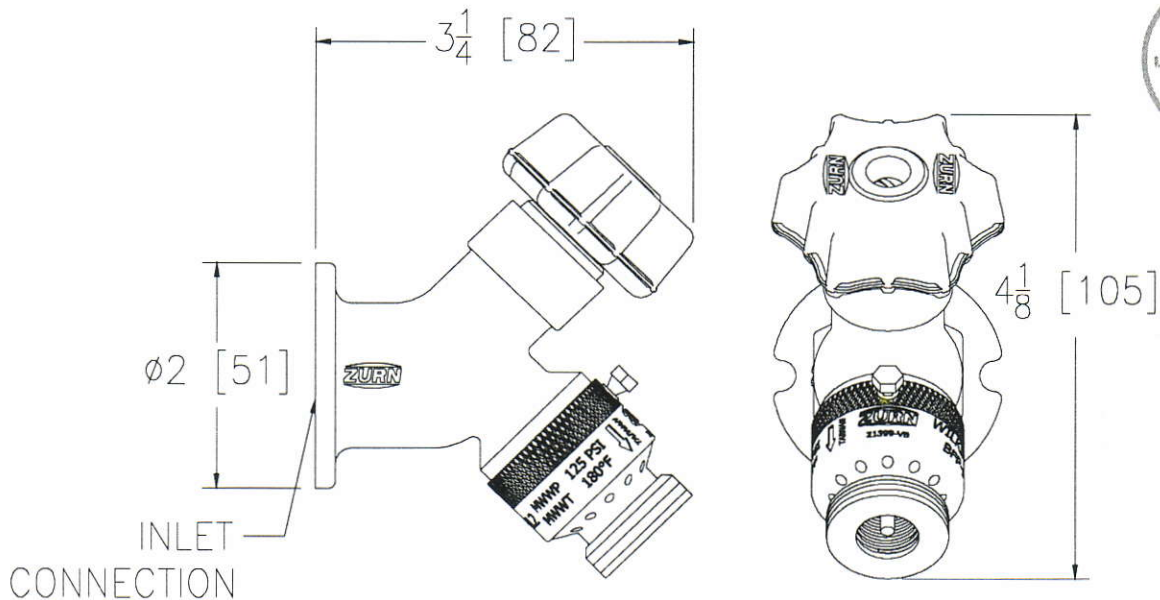

### -P12 and -P34 Inlet Connection Shown

Inlet Connection	Inlet Description in [mm]	Approx. Wt. lbs [kg]
___ -C12	1/2 [13] Solder x 3/4 [19] Solder	2 [1]
___ -C12-PX	1/2 [13] PEX	2 [1]
___ -CP12	1/2 [13] Solder x 1/2 [13] MPT	2 [1]
___ -P12	1/2 [13] FPT	2 [1]
___ -P34	3/4 [19] FPT	2 [1]

### ENGINEERING SPECIFICATION: ZURN Z1341XL

Exposed, lead-free, anti-siphon, moderate climate wall hydrant for residential and light commercial applications. Hydrant features Z1399-VB external vacuum breaker with 3/4" [19] male hose connection, bronze and stainless steel interior components, vandal resistant operating stem, and secured wheel-type handle. Hydrant is finished with rough bronze exterior with a choice of five different inlet connection options and includes an optional loose key.

### OPTIONS (Check/specify appropriate options)

#### SUFFIXES

- \_\_\_ -PB Polished Bronze Finish
- \_\_\_ -PC Polished Chrome Finish
- \_\_\_ -RC Rough Chrome Finish
- \_\_\_ -RK Hydrant Parts Repair Kit

*Zurn "XL" Lead-Free compliant products are a line of durable plumbing products designed and manufactured to comply with state laws and local codes that mandate maximum allowable lead content levels. Zurn "XL" products are manufactured in accordance to the Federal SWDA section 1417.*

\* Regularly furnished unless otherwise specified.

Zurn Industries, LLC | Specification Drainage Operation  
1801 Pittsburgh Avenue, Erie, PA U.S.A. 16502 · Ph. 855-663-9876, Fax 814-454-7929  
In Canada | Zurn Industries Limited  
3544 Nashua Drive, Mississauga, Ontario L4V 1L2 · Ph. 905-405-8272, Fax 905-405-1292  
[www.zurn.com](http://www.zurn.com)

Rev. -  
Date: 3/23/15  
C.N. No. 131803  
Prod. | Dwg. No. Z1341XL